



KATALOG SYSTEMÓW
OGRODZENIOWYCH





BRAMY ■ OGRODZENIA
GATES ■ FENCES
TORE ■ ZAUNSYSTEME
ВОРОТА ■ ОГРАЖДЕНИЯ



- PL** - Rysunki ogrodzeń przedstawiono w widoku od strony ulicy
EN - Drawings of fences - view from the street
DE - Darstellung der Zaunzeichnungen mit Straßenansicht
RU - Рисунки ограждений представлены в виде со стороны улицы

PL - Rysunki w **Katalogu Systemów Ogrodzeniowych** posiadają standardowo wymiary:

Segmenty - $S = 2500$ [mm]

Bramy - $S_o = 3500$ [mm]

Furtki - $S_o = 1000$ [mm]

EN - Figures in the **Catalogue of Fencing Systems** are of the following dimensions:

Segments - $S = 2500$ [mm]

Gates - $S_o = 3500$ [mm]

Wickets - $S_o = 1000$ [mm]

DE - Skizzen im **Zaunsysteme-Katalog** haben Standardausmaßen:

Zaunfelder - $S = 2500$ [mm]

Tore - $S_o = 3500$ [mm]

Pforten - $S_o = 1000$ [mm]

RU - Рисунки в **Каталоге Систем Ограждения** стандартно имеют следующие размеры:

Секции - $S = 2500$ [mm]



Ворота - $S_o = 3500$ [mm]

Калитки - $S_o = 1000$ [mm]

Wszelkie prawa zastrzeżone ■ All rights reserved

Spis treści ■ Contents
Inhaltsverzeichnis ■ Содержание

Strona ■ Page
Seite ■ Страница

	System <i>Lux</i>	4 - 67
	System <i>Style</i>	68 - 103
	System <i>Classic</i>	104 - 143
Informacje techniczne ■ Technical informations Technische Informationen ■ Техническая информация		144 - 165



System **Lox**
AW.10.31

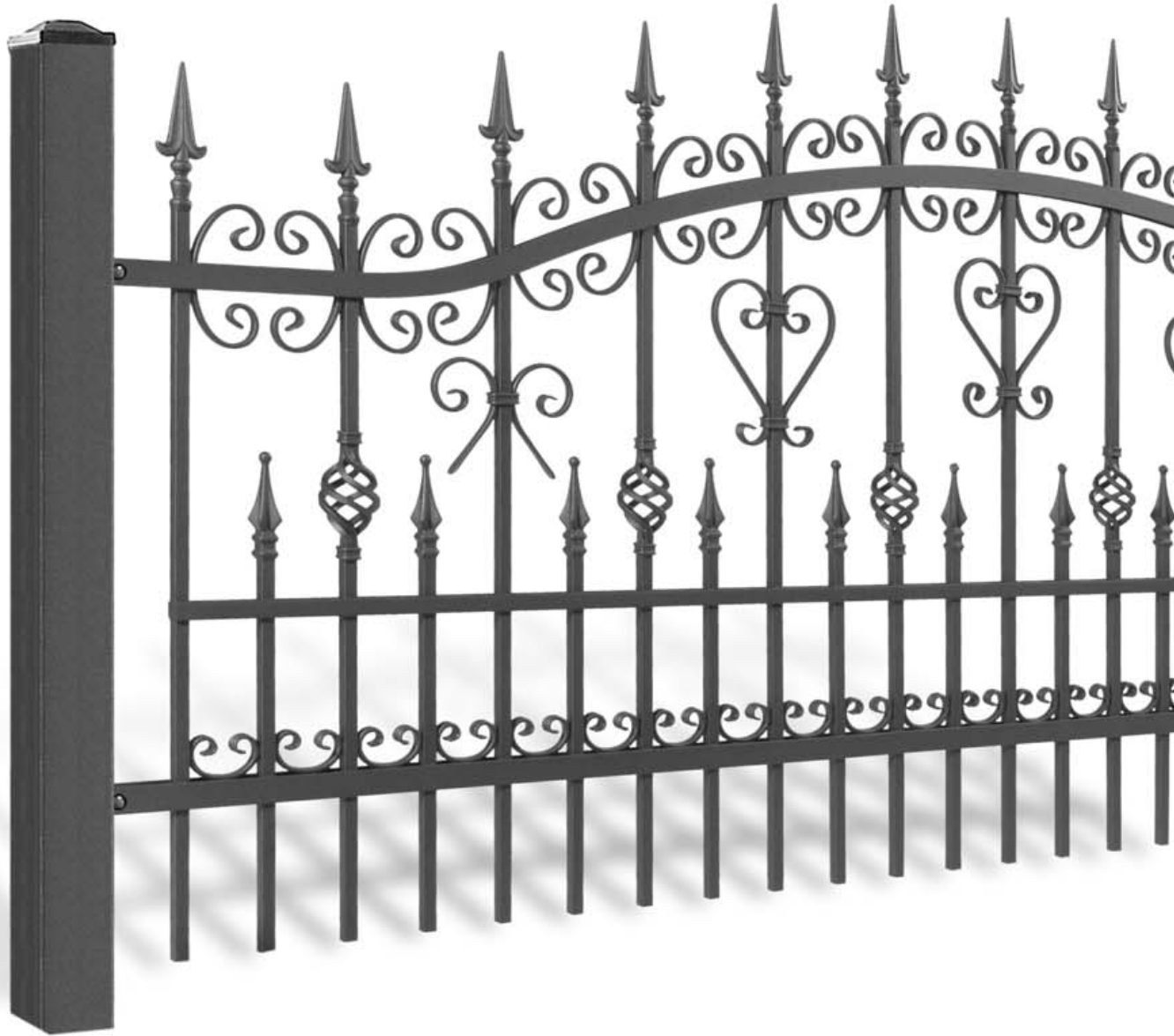



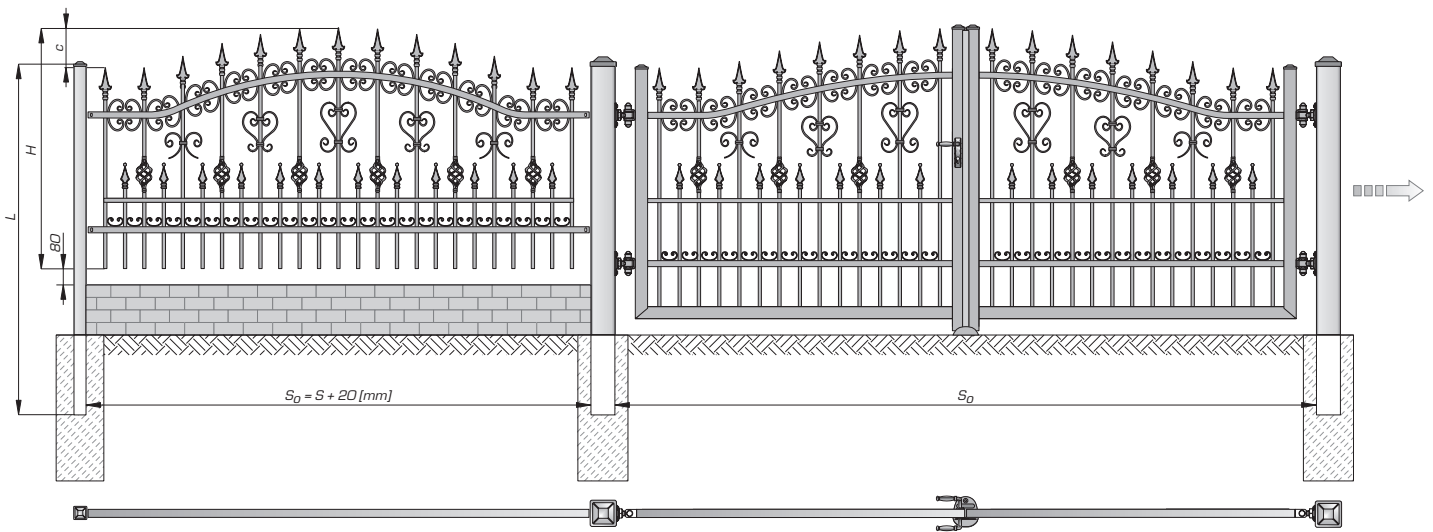
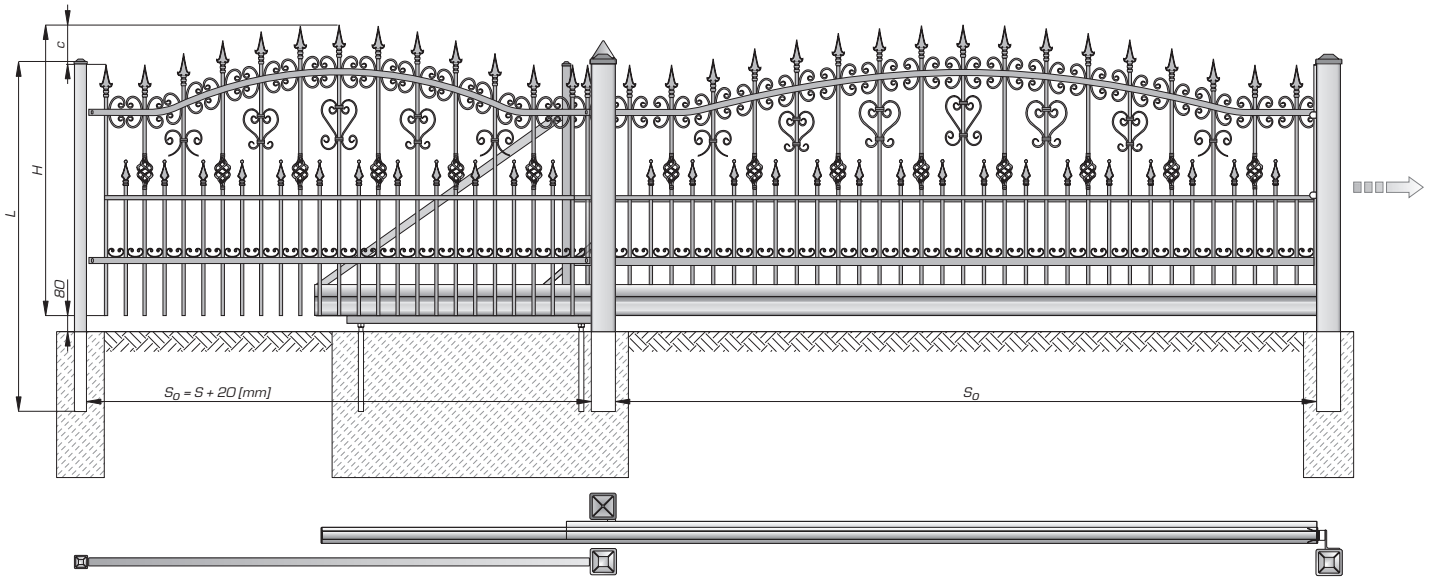

AW.10.31/Wp

(S) 2500 [mm] x (H) 1200 [mm] - 67 kg (S) 2500 [mm] x (H) 1450 [mm] - 75 kg
 max: (S) 3000 [mm] x (H) 1750 [mm]

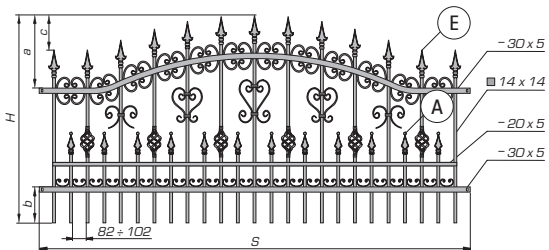

H=1450 : a=420, b=300, c=200, H_{min}=1000 H=1200 : a=420, b=100 ÷ 300, c=200, H_{min}=1000

AW.10.31/P

(S) 2500 [mm] x (H) 1200 [mm] - 70 kg (S) 2500 [mm] x (H) 1450 [mm] - 78 kg
 max: (S) 3000 [mm] x (H) 1750 [mm]

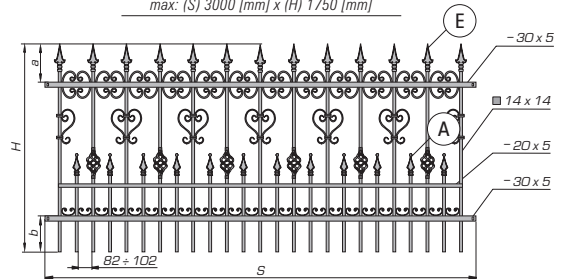

H=1450 : a=220, b=300, H_{min}=1000 H=1200 : a=220, b=100 ÷ 300, H_{min}=1000

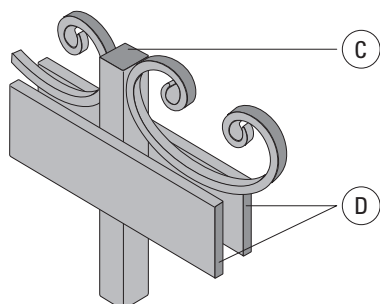
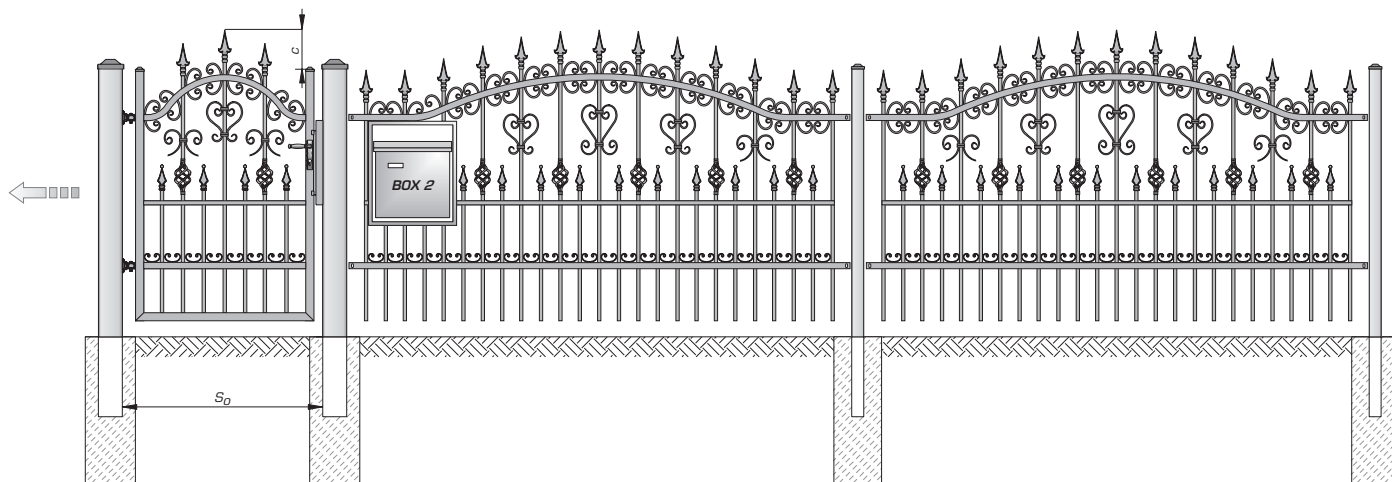
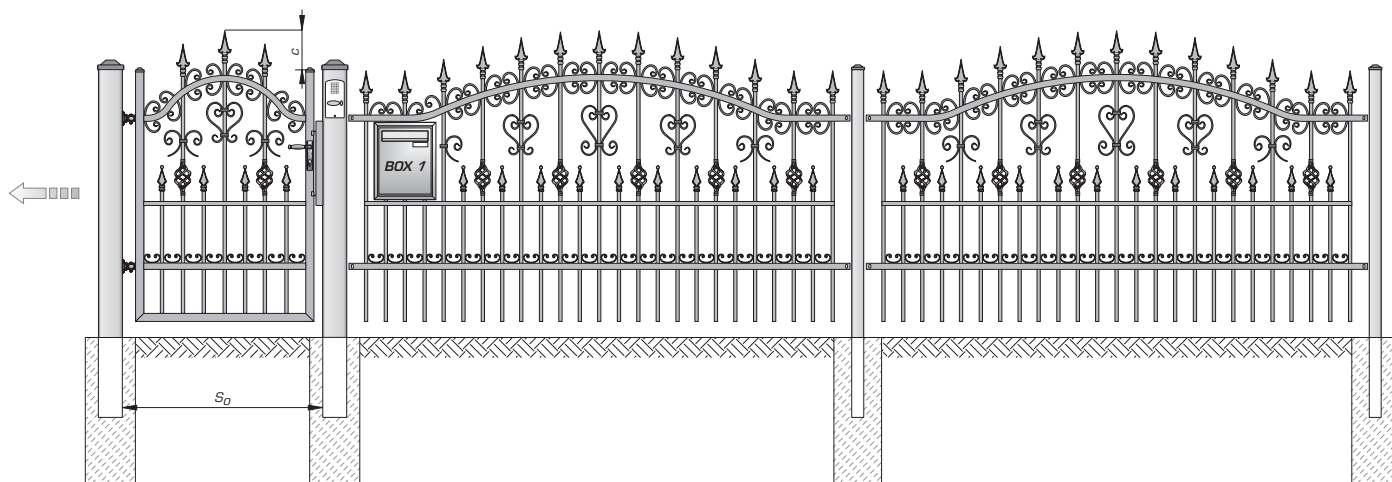

U3 C 14 x 14 D 30 x 5



System Łódź
AW.10.33



System Łoux
AW.10.33



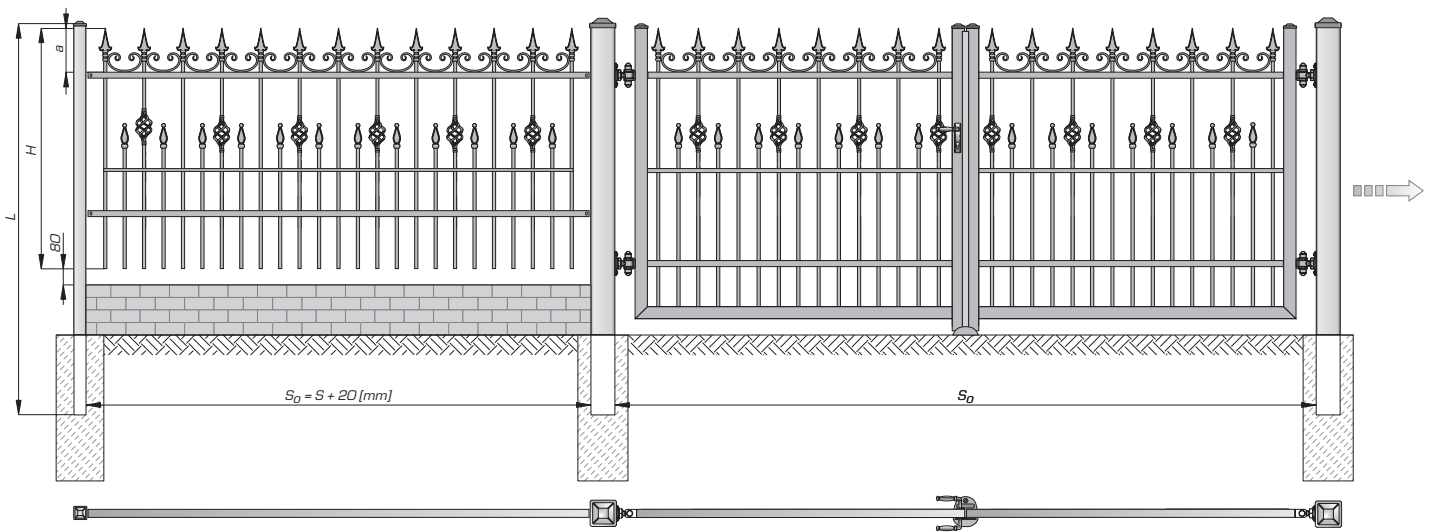
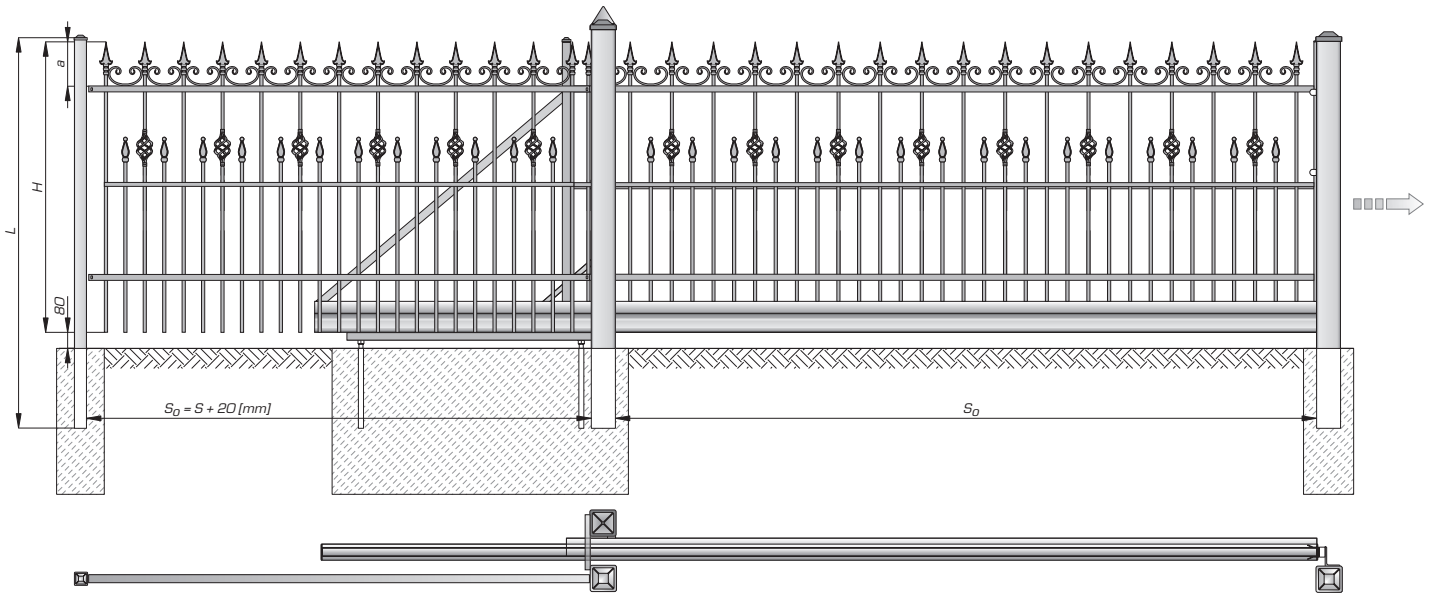

AW.10.33/P

(S) 2500 [mm] x (H) 900 [mm] - 55 kg
 (S) 2500 [mm] x (H) 1200 [mm] - 65 kg
 (S) 2500 [mm] x (H) 1450 [mm] - 75 kg
 max: (S) 3000 [mm] x (H) 1750 [mm]

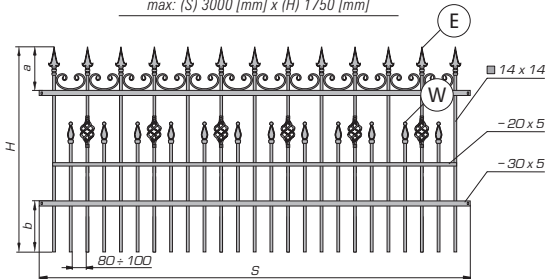

H=1450 : a=250, b=300, H_{min}=800
 H=1200 : a=250, b=300, H_{min}=800

AW.10.33/Wp

(S) 2500 [mm] x (H) 1200 [mm] - 62 kg
 (S) 2500 [mm] x (H) 1450 [mm] - 72 kg
 max: (S) 3000 [mm] x (H) 1750 [mm]

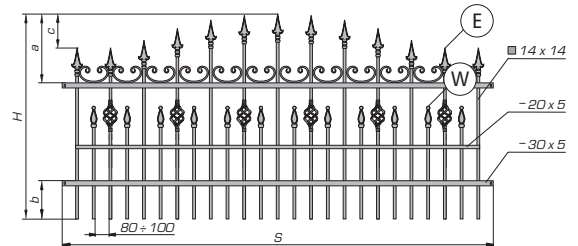

H=1450 : a=400, b=300, c=200, H_{min}=1000
 H=1200 : a=400, b=100+300, c=200, H_{min}=1000

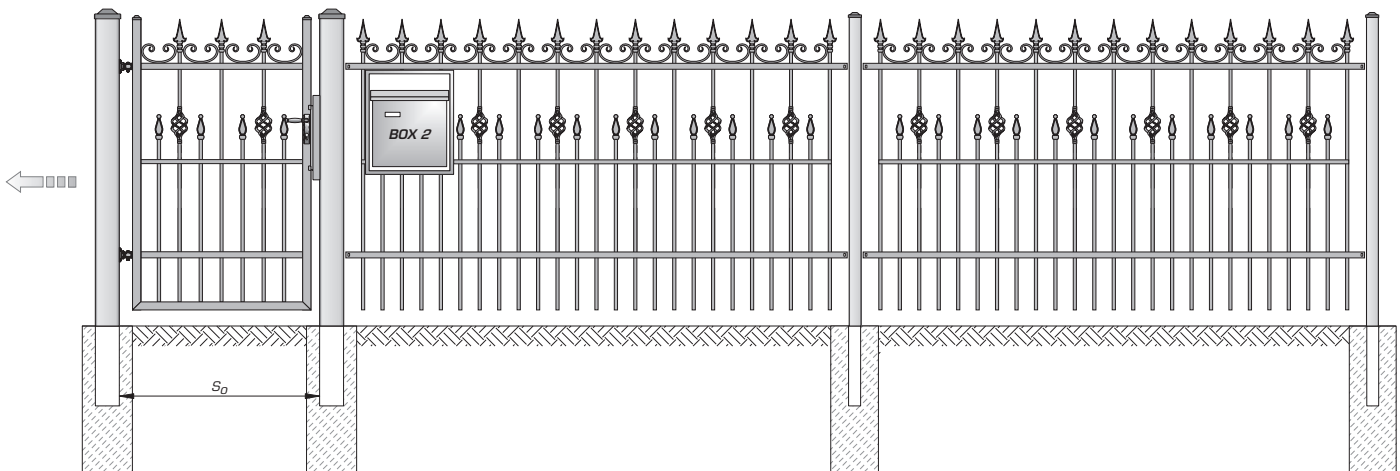
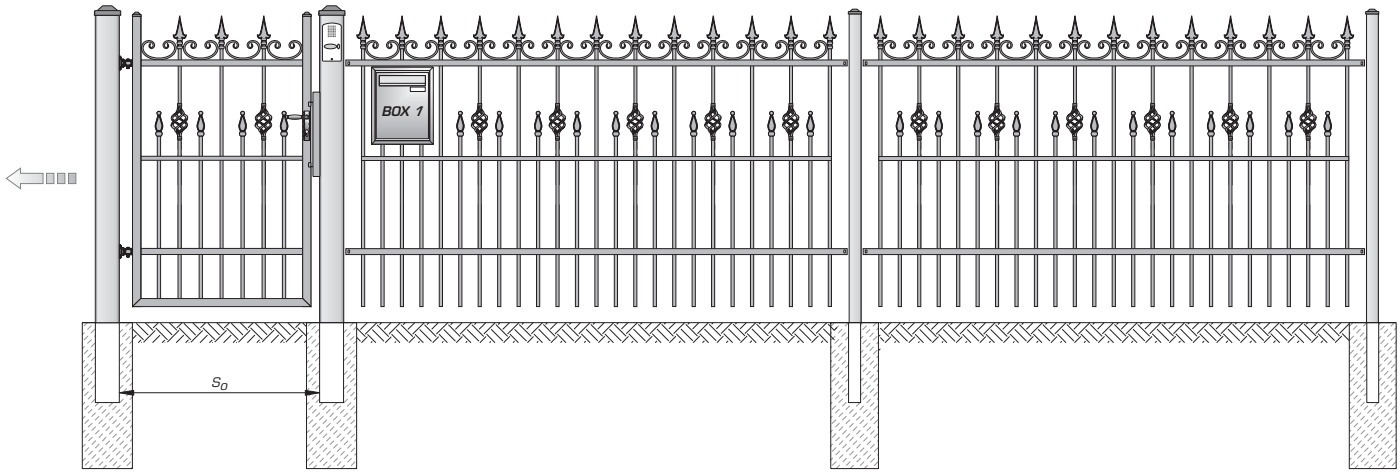

AW.10.33/Wk

(S) 2500 [mm] x (H) 1200 [mm] - 62 kg (S) 2500 [mm] x (H) 1450 [mm] - 72 kg
max: (S) 3000 [mm] x (H) 1750 [mm]

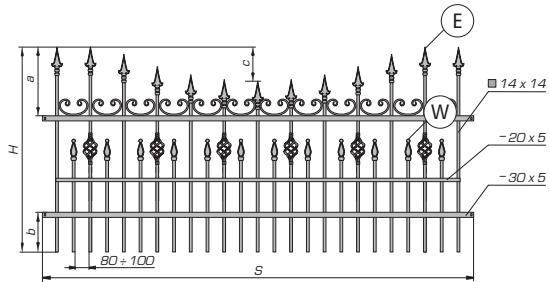

$H=1450 : a=400, b=300, c=200, H_{min}=1000$ $H=1200 : a=400, b=100 \div 300, c=200, H_{min}=1000$

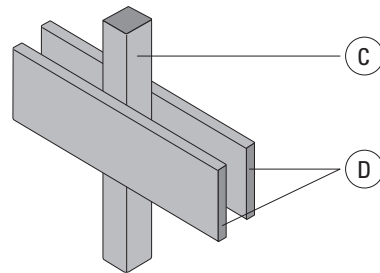

U3 C 14 x 14 D 30 x 5



System **Lox**
AW.10.34



System Łoux
AW.10.34



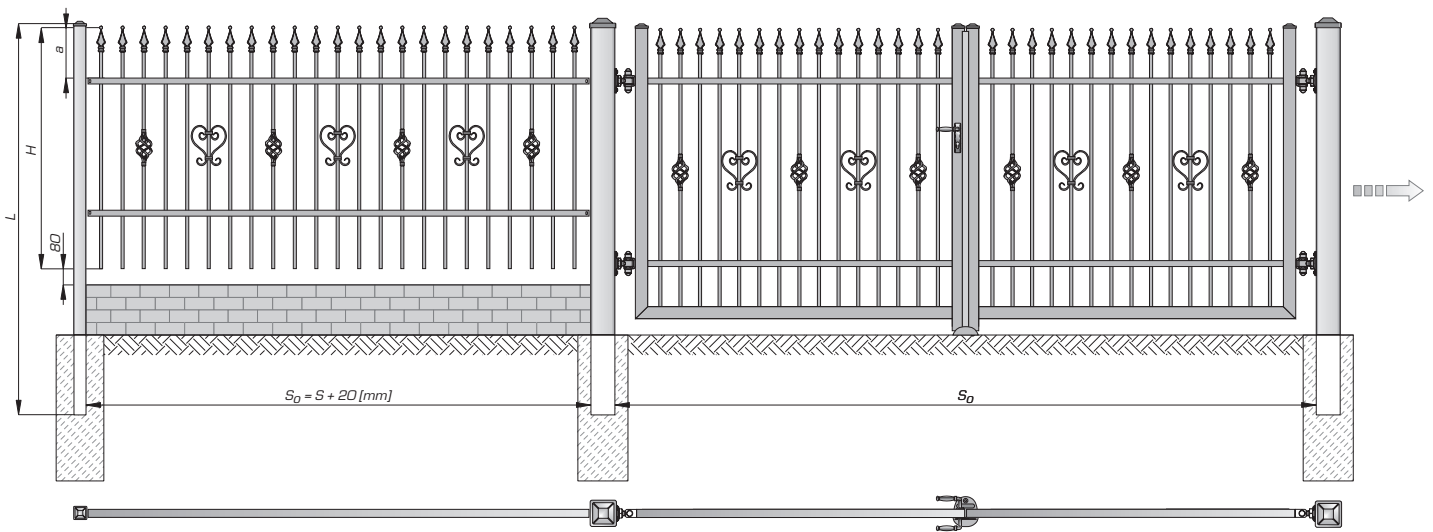
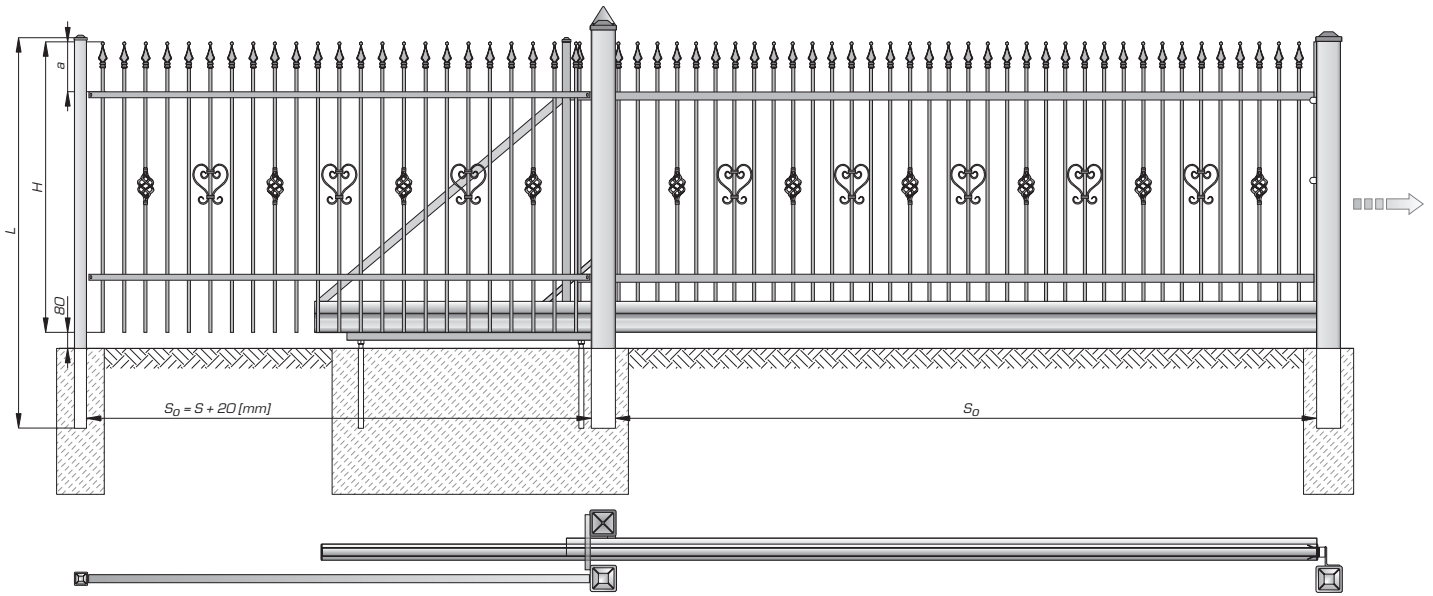

AW.10.34/P

(S) 2500 [mm] x (H) 900 [mm] - 56 kg
 (S) 2500 [mm] x (H) 1200 [mm] - 66 kg
 (S) 2500 [mm] x (H) 1450 [mm] - 76 kg
 max: (S) 3000 [mm] x (H) 1750 [mm]

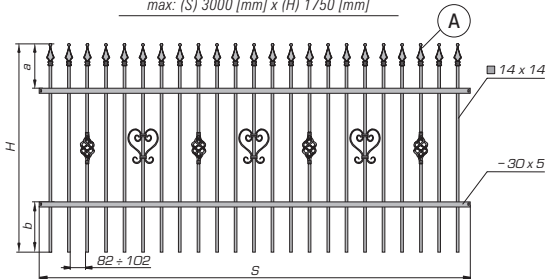

H=1450 : a=250, b=300, H_{min}=800
 H=1200 : a=250, b=300, H_{min}=800

AW.10.34/Wp

(S) 2500 [mm] x (H) 1200 [mm] - 63 kg
 (S) 2500 [mm] x (H) 1450 [mm] - 73 kg
 max: (S) 3000 [mm] x (H) 1750 [mm]

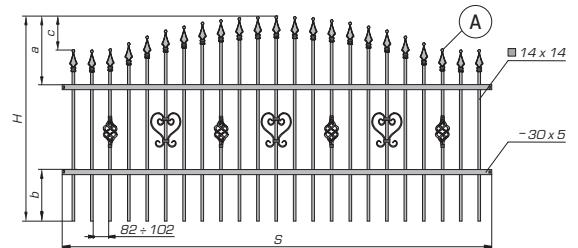

H=1450 : a=400, b=300, c=200, H_{min}=1000
 H=1200 : a=400, b=100+300, c=200, H_{min}=1000

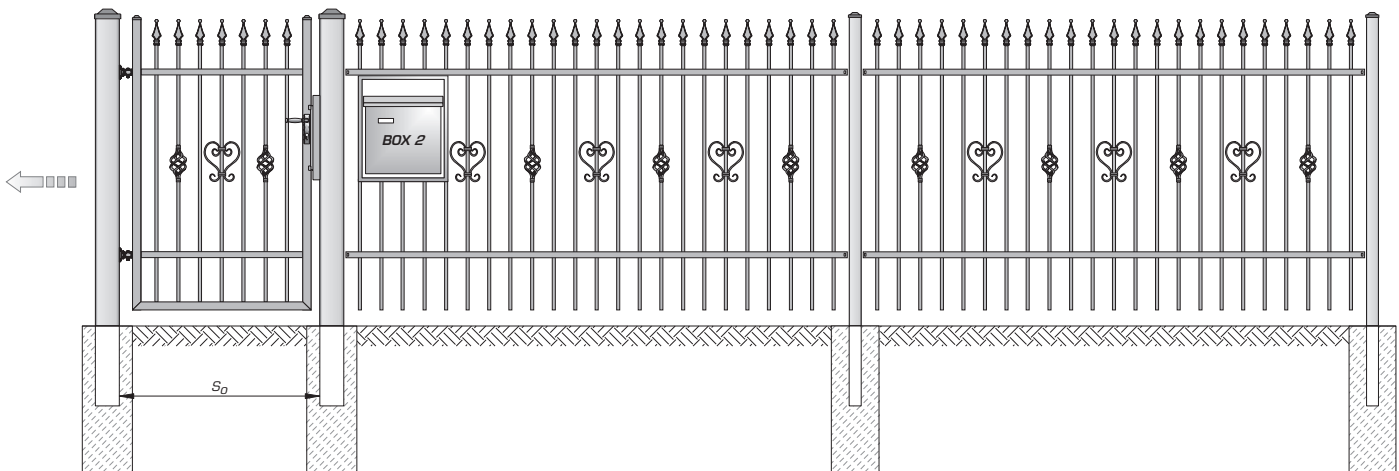
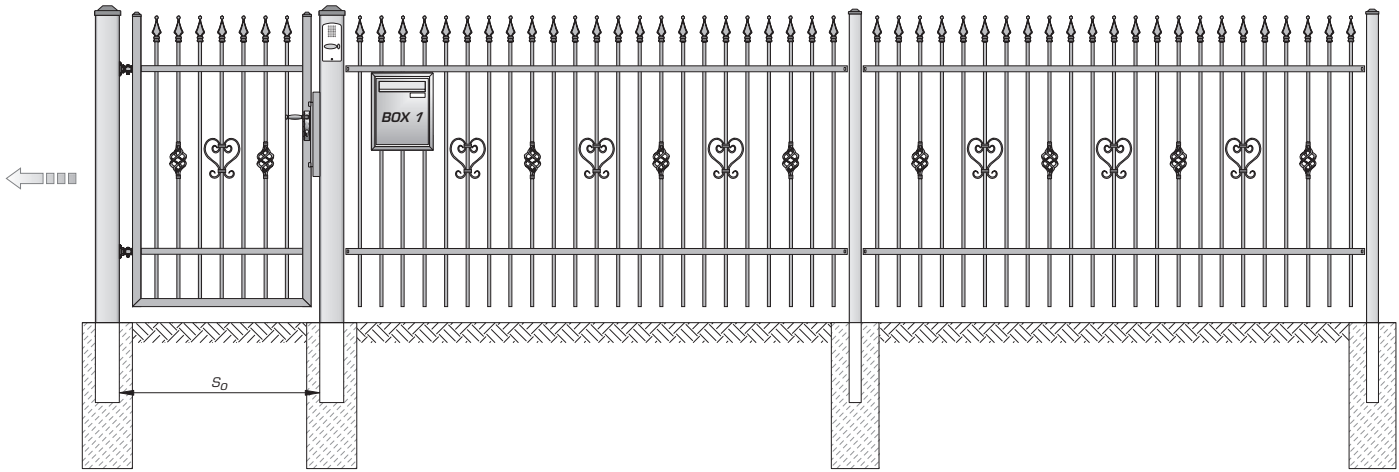

AW.10.34/Wk

(S) 2500 [mm] x (H) 1200 [mm] - 63 kg (S) 2500 [mm] x (H) 1450 [mm] - 73 kg
max: (S) 3000 [mm] x (H) 1750 [mm]

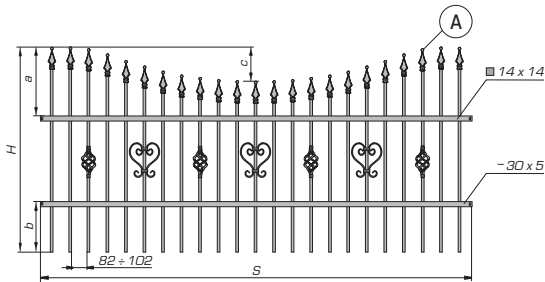

$H=1450 : a=400, b=300, c=200, H_{min}=1000$ $H=1200 : a=400, b=100 \div 300, c=200, H_{min}=1000$

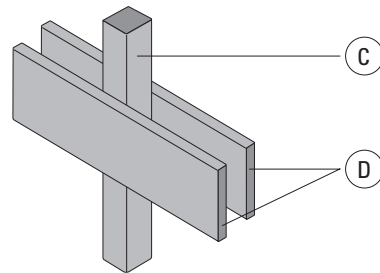

U3 C 14 x 14 D 30 x 5



System Łux
AW.10.39



System Ł&X
AW.10.39



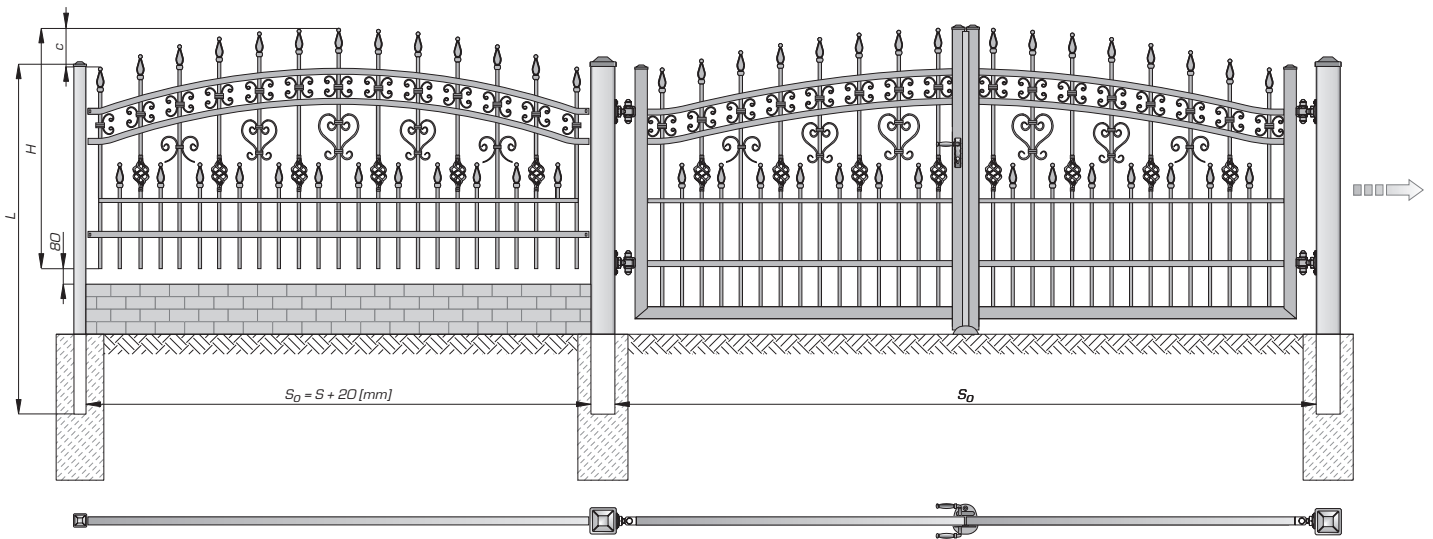
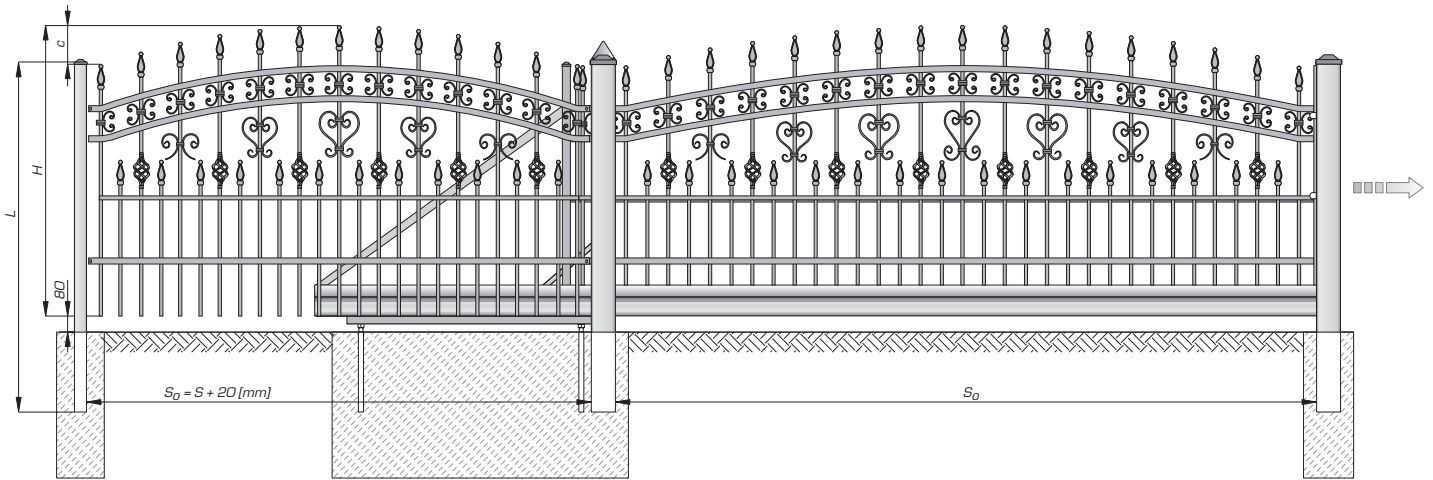

AW.10.39/Wp

(S) 2500 [mm] x (H) 1200 [mm] - 67 kg (S) 2500 [mm] x (H) 1450 [mm] - 76 kg
 max: (S) 3000 [mm] x (H) 1750 [mm]

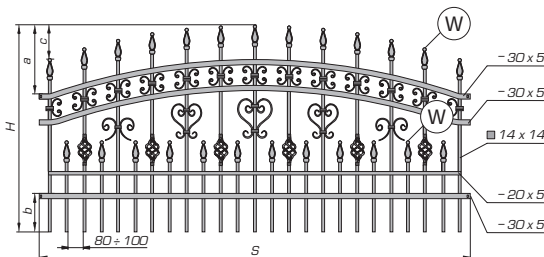

H=1450 : a=400, b=300, c=200, H_{min}=1000 H=1200 : a=400, b=100 ÷ 300, c=200, H_{min}=1000

AW.10.39/P

(S) 2500 [mm] x (H) 1200 [mm] - 70 kg (S) 2500 [mm] x (H) 1450 [mm] - 79 kg
 max: (S) 3000 [mm] x (H) 1750 [mm]

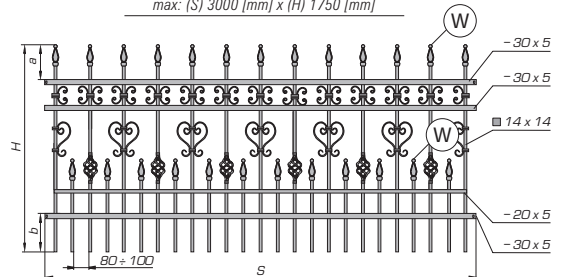

H=1450 : a=250, b=300, H_{min}=1000 H=1200 : a=200 ÷ 250, b=100 ÷ 300, H_{min}=1000

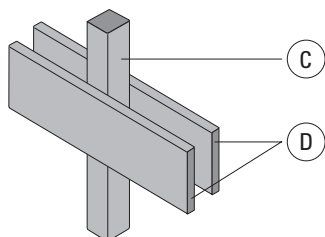
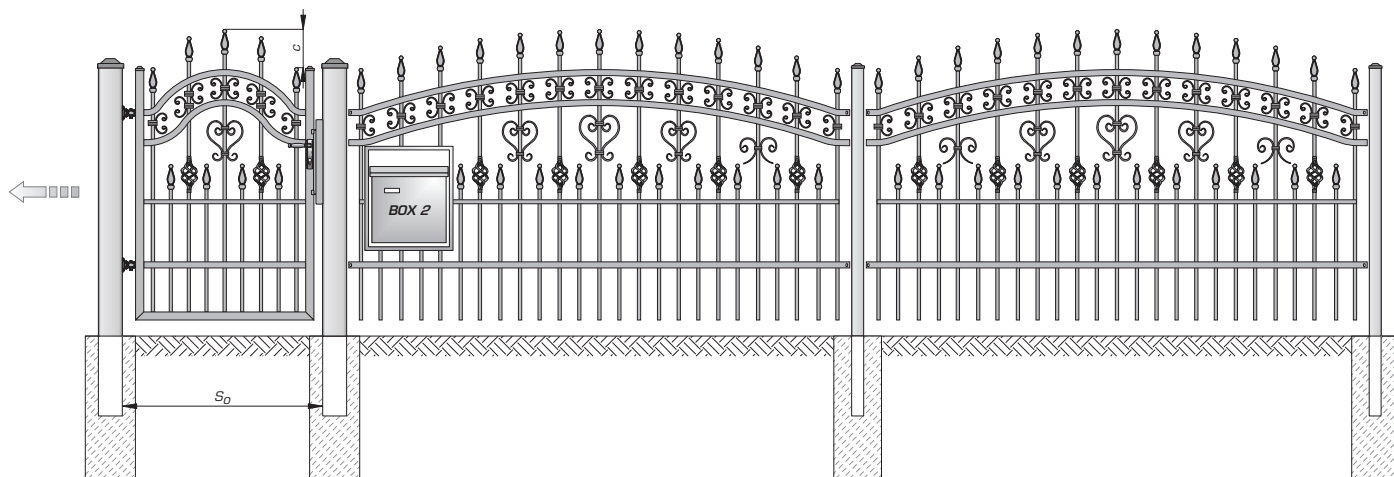
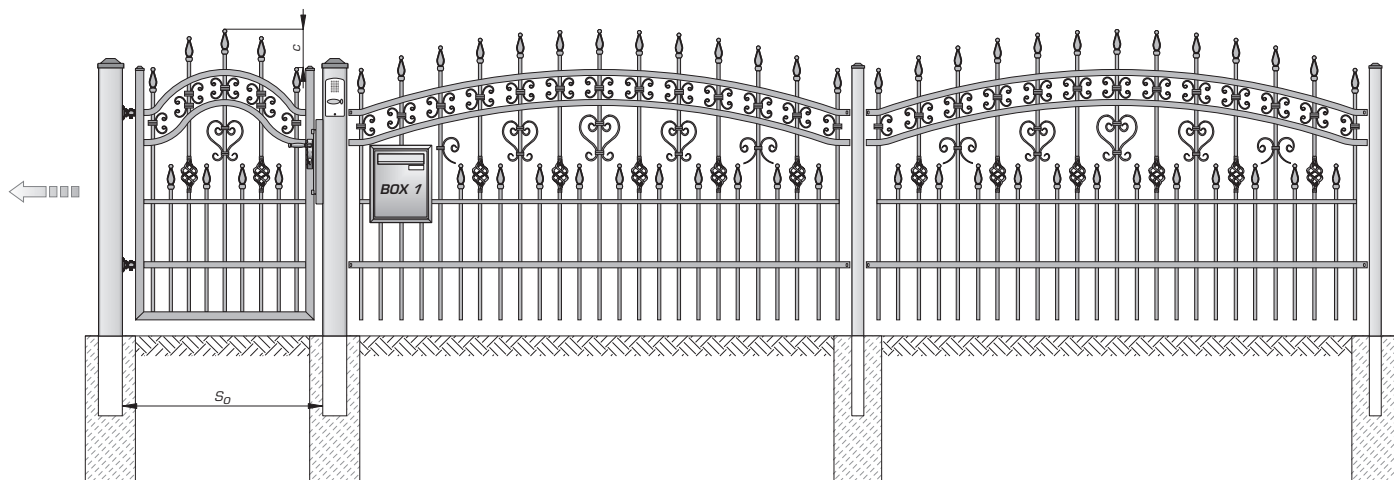

U3

C 14 x 14 D 30 x 5

AW.10.39/Wp

AW.10.39/Wp

AW.10.39/P

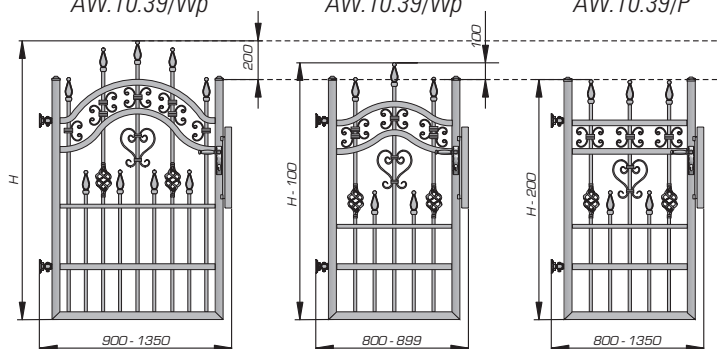

- PL / Zmiana wysokości furty w zależności od szerokości
- EN / Change of wicket height depending on its width
- DE / Änderung der Pforteshöhe abhängig von Breite
- RU / Изменение высоты капитки в зависимости от ширины



System **Lox**
AW.10.45

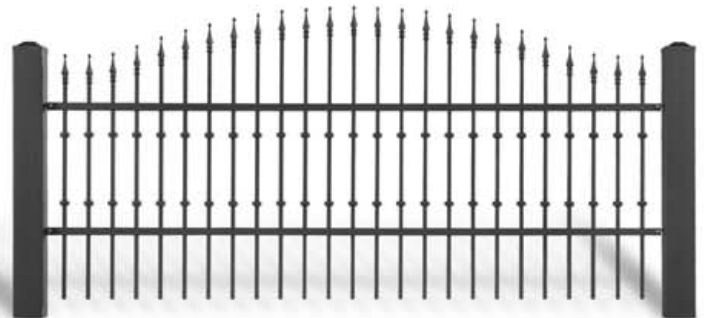
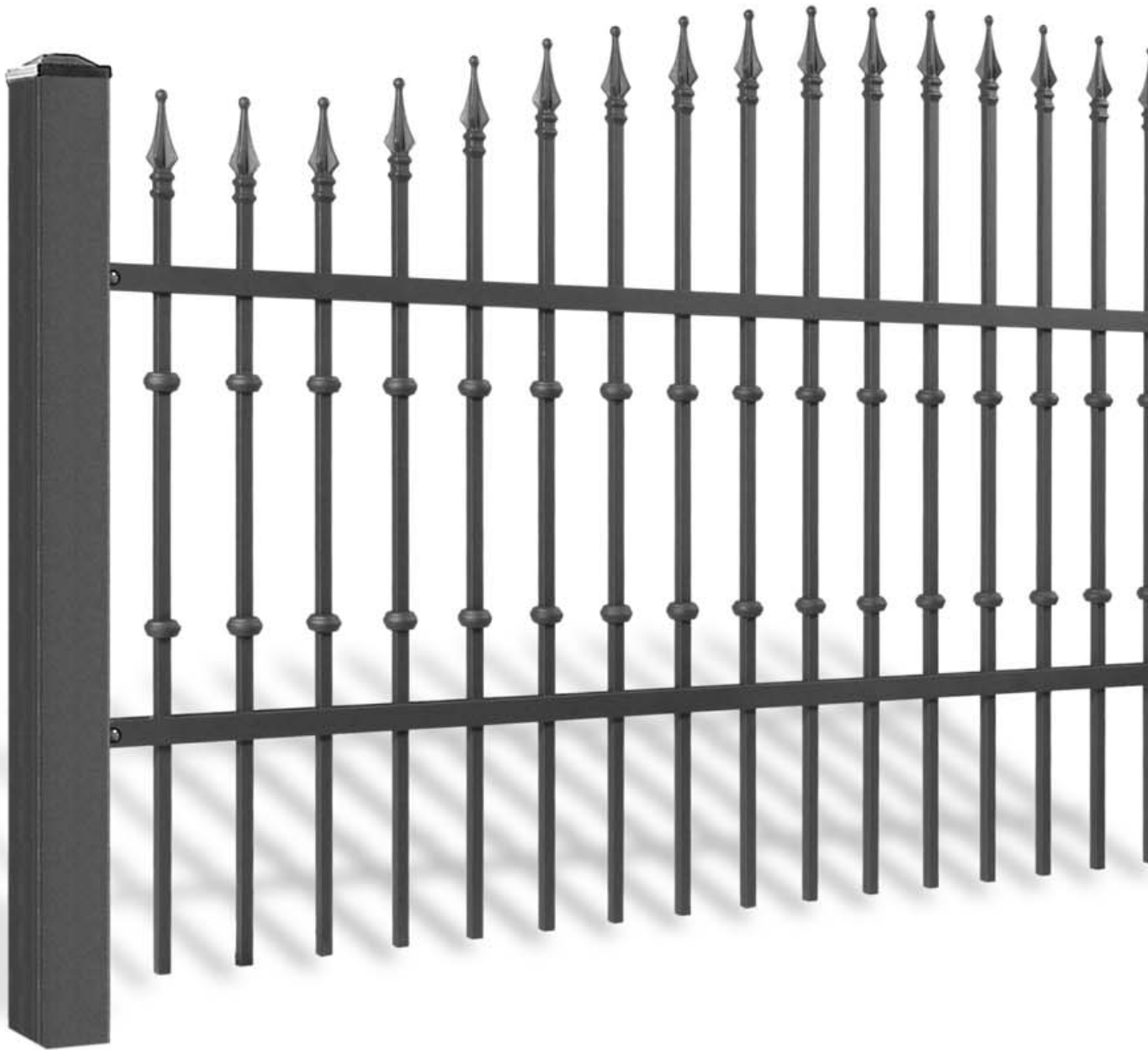

System Łux
AW.10.45



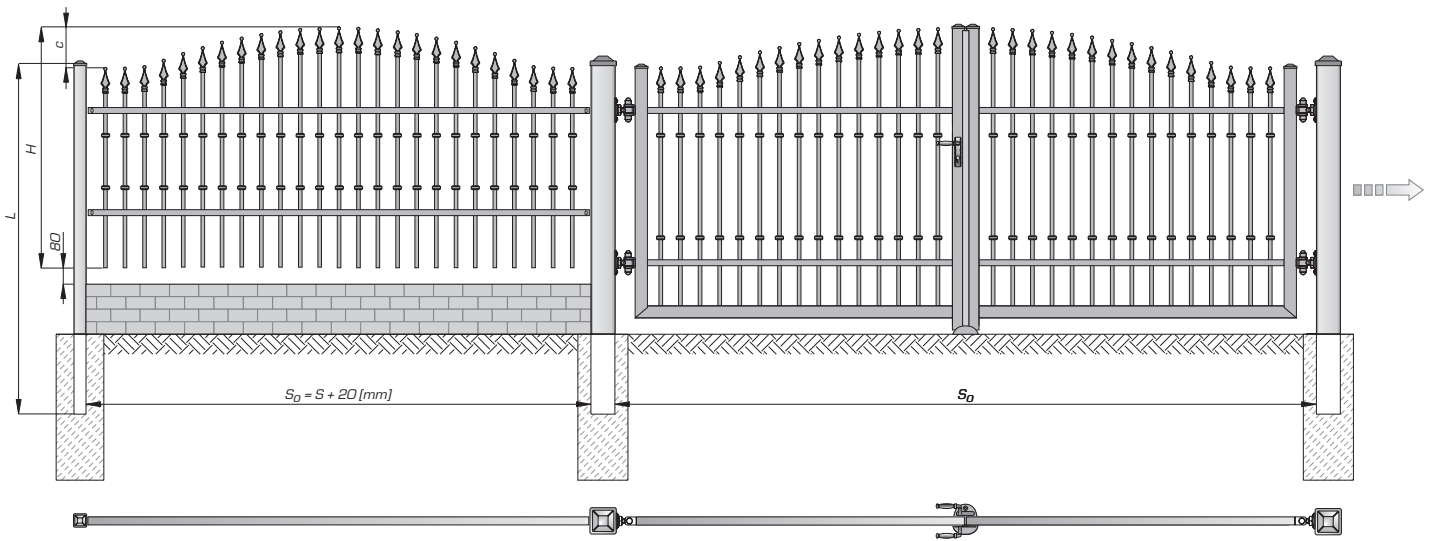
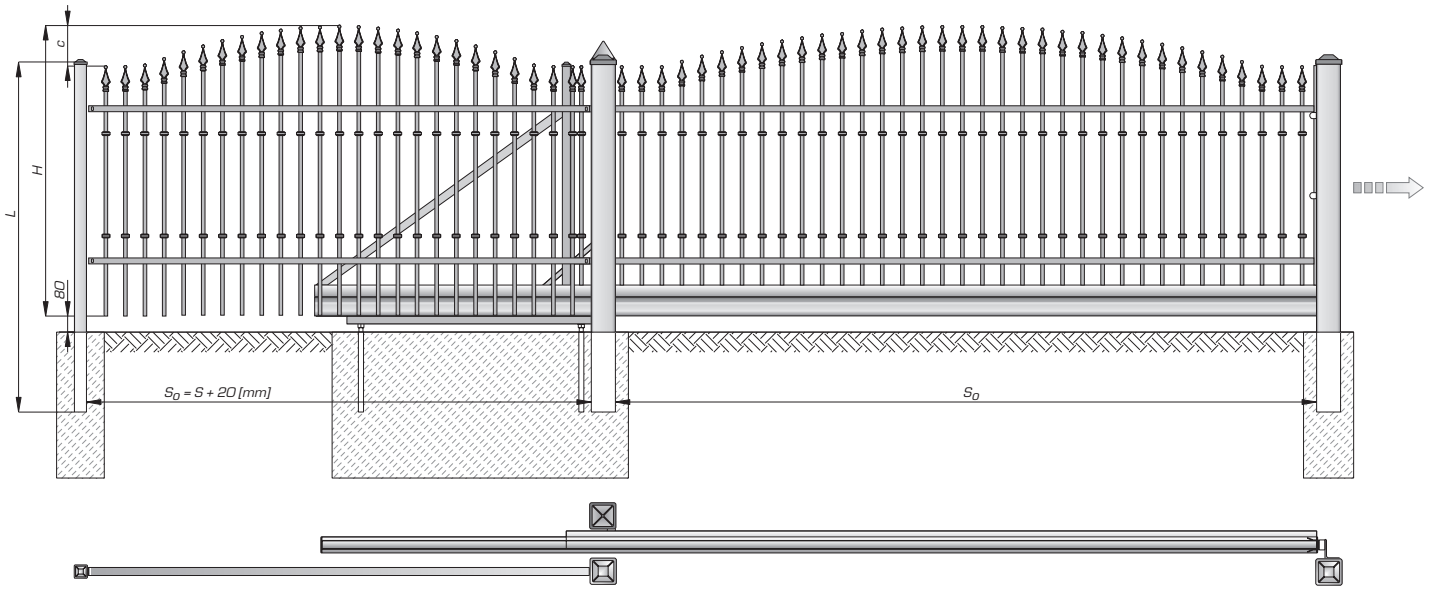

AW.10.45/Wp

(S) 2500 [mm] x (H) 1200 [mm] - 65 kg (S) 2500 [mm] x (H) 1450 [mm] - 75 kg
 max: (S) 3000 [mm] x (H) 1750 [mm]

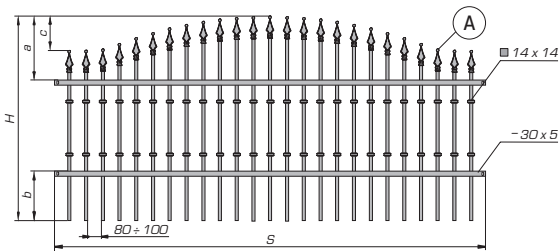

H=1450 : a=400, b=300, c=200, H_{min}=1000 H=1200 : a=400, b=100+300, c=200, H_{min}=1000

AW.10.45/P

(S) 2500 [mm] x (H) 900 [mm] - 58 kg (S) 2500 [mm] x (H) 1450 [mm] - 78 kg
 (S) 2500 [mm] x (H) 1200 [mm] - 68 kg
 max: (S) 3000 [mm] x (H) 1750 [mm]

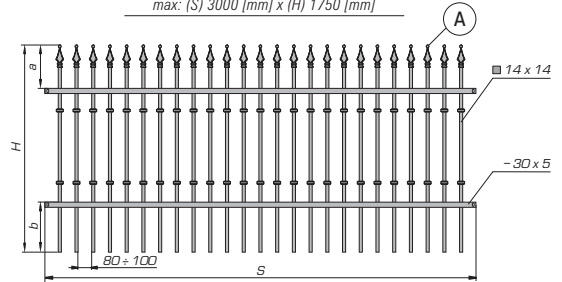

H=1450 : a=250, b=300, H_{min}=800 H=1200 : a=250, b=300, H_{min}=800

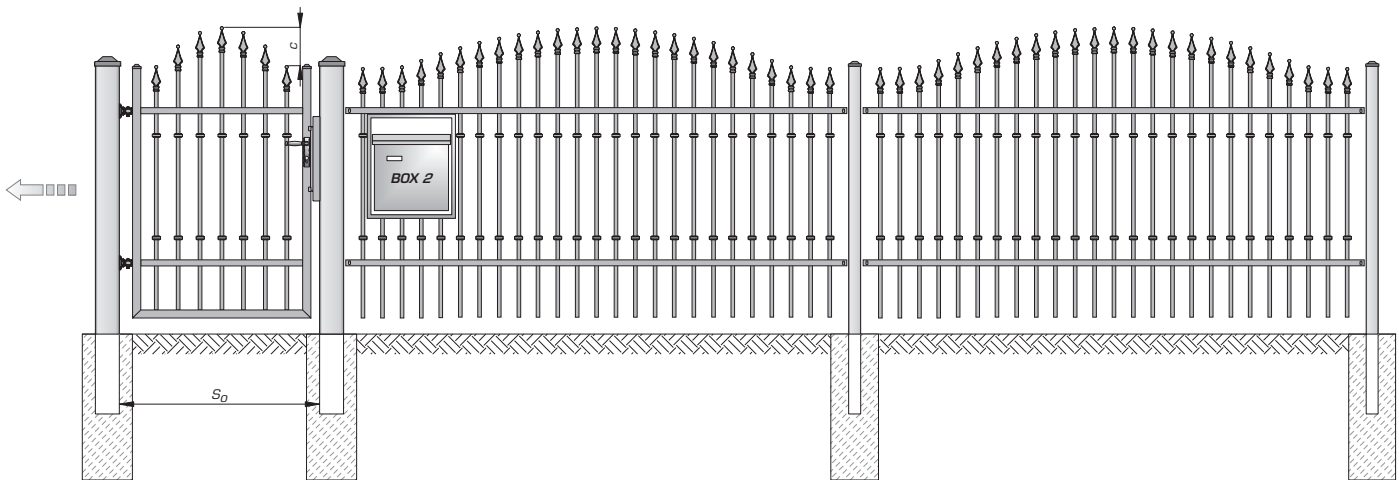
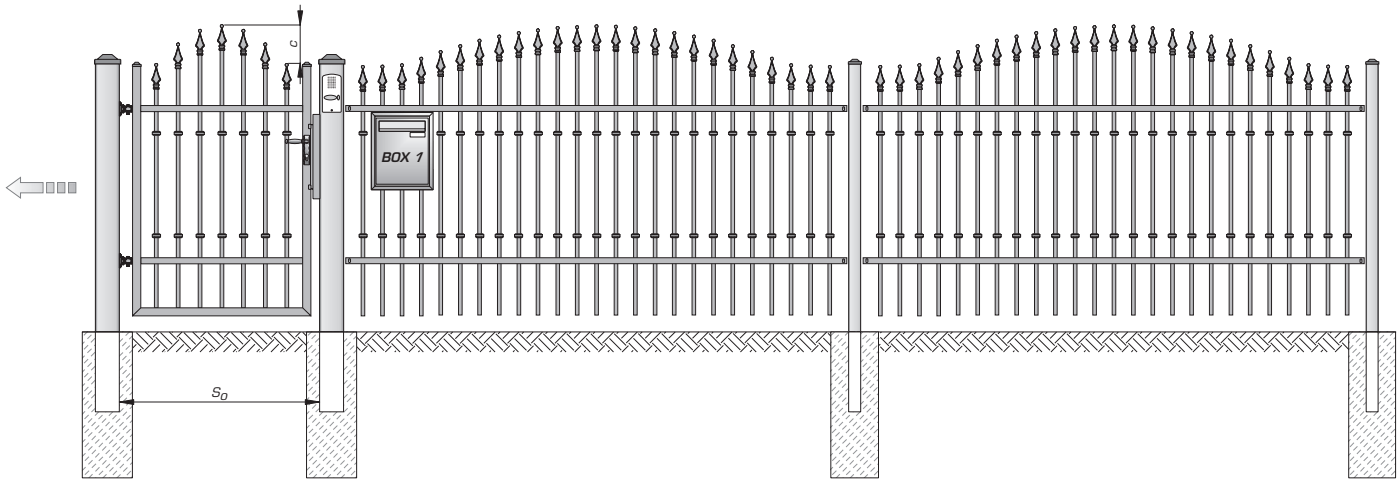

AW.10.45/WK

(S) 2500 [mm] x (H) 1200 [mm] - 65 kg (S) 2500 [mm] x (H) 1450 [mm] - 75 kg
max: (S) 3000 [mm] x (H) 1750 [mm]

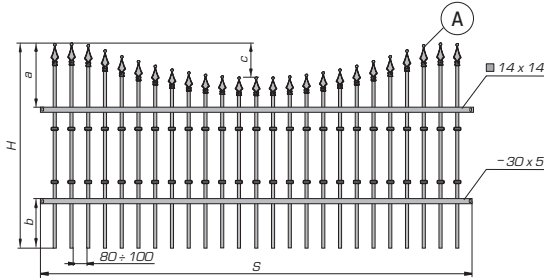

H=1450 : a=400, b=300, c=200, H_{min}=1000 H=1200 : a=400, b=100 ÷ 300, c=200, H_{min}=1000

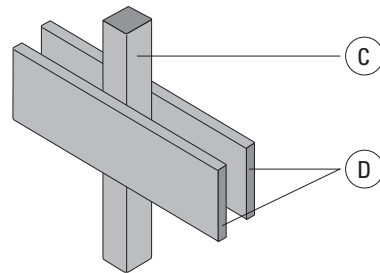

U3 C 14 x 14 D 30 x 5



System Łux
AW.10.46

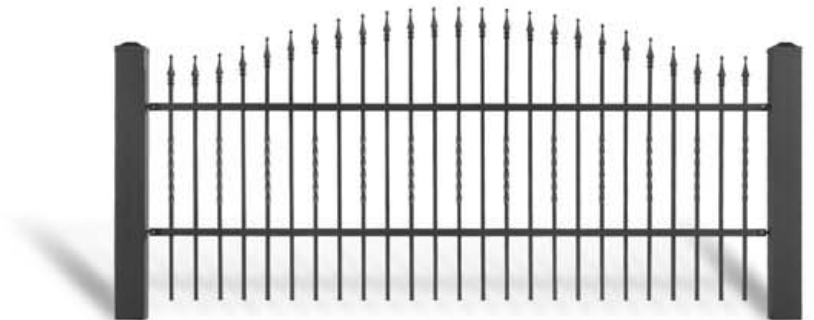
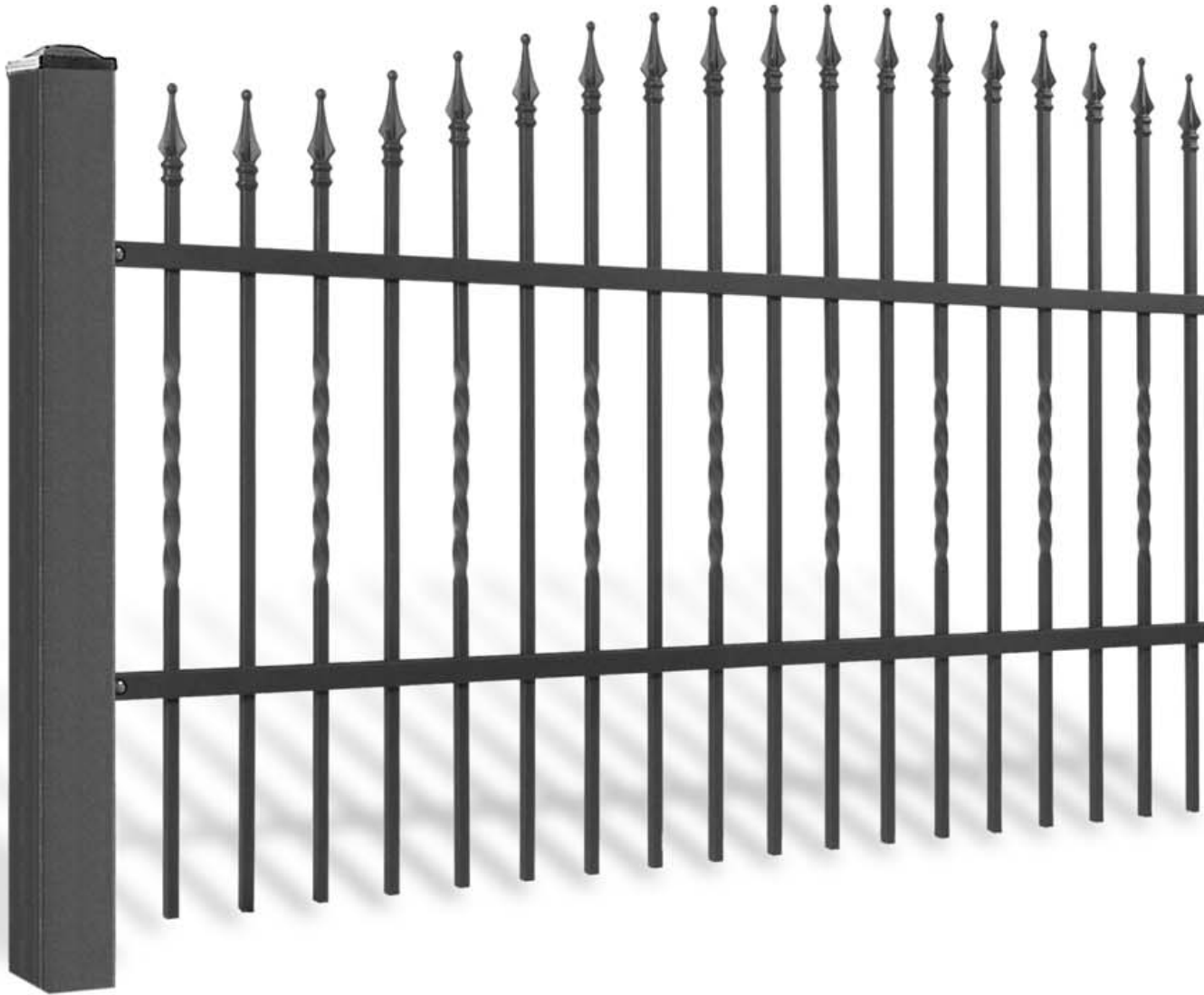

System Łux
AW.10.46

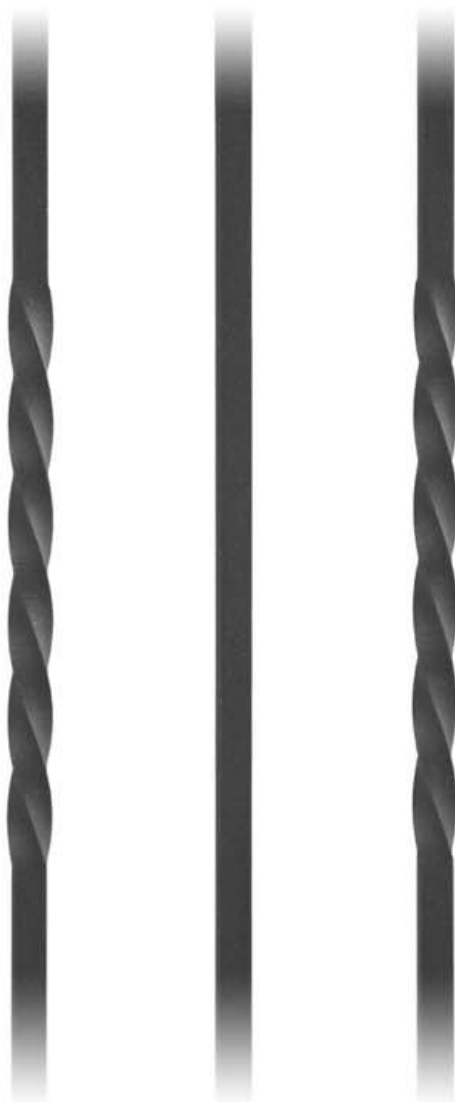

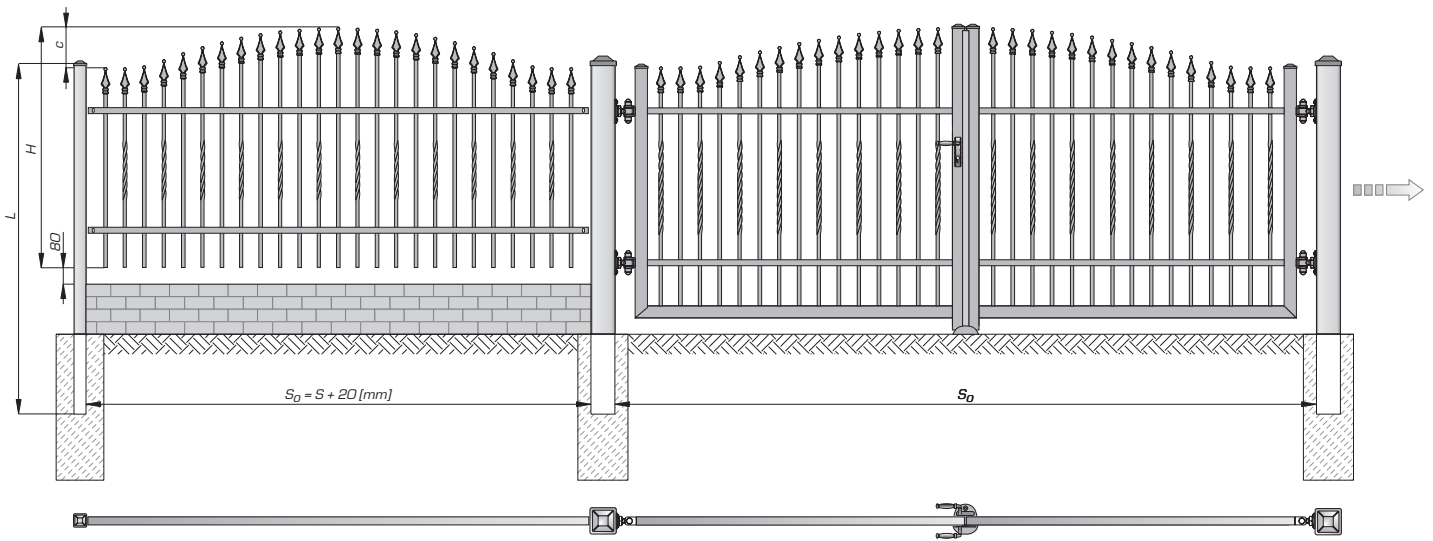
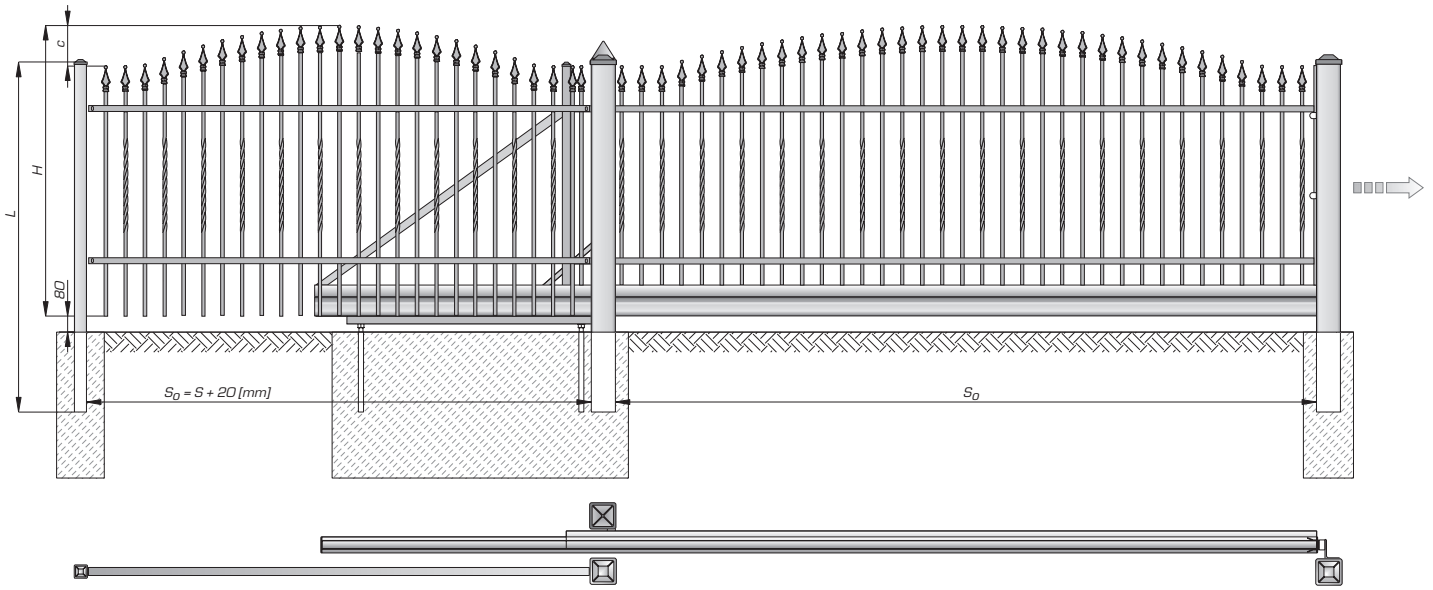

AW.10.46/Wp

(S) 2500 [mm] x (H) 1200 [mm] - 58 kg (S) 2500 [mm] x (H) 1450 [mm] - 69 kg
 max: (S) 3000 [mm] x (H) 1750 [mm]

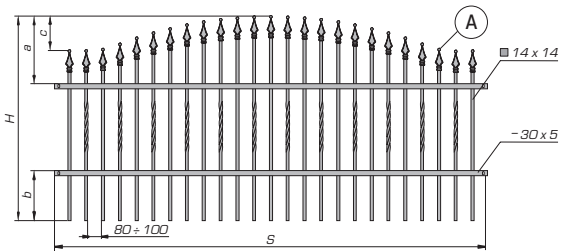

H=1450 : a=400, b=300, c=200, H_{min}=1000 H=1200 : a=400, b=100+300, c=200, H_{min}=1000

AW.10.46/P

(S) 2500 [mm] x (H) 900 [mm] - 50 kg (S) 2500 [mm] x (H) 1450 [mm] - 72 kg
 (S) 2500 [mm] x (H) 1200 [mm] - 61 kg
 max: (S) 3000 [mm] x (H) 1750 [mm]

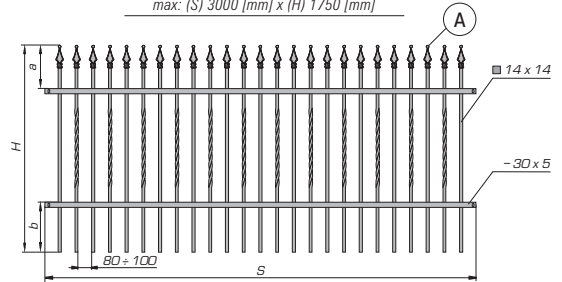

H=1450 : a=250, b=300, H_{min}=800 H=1200 : a=250, b=300, H_{min}=800

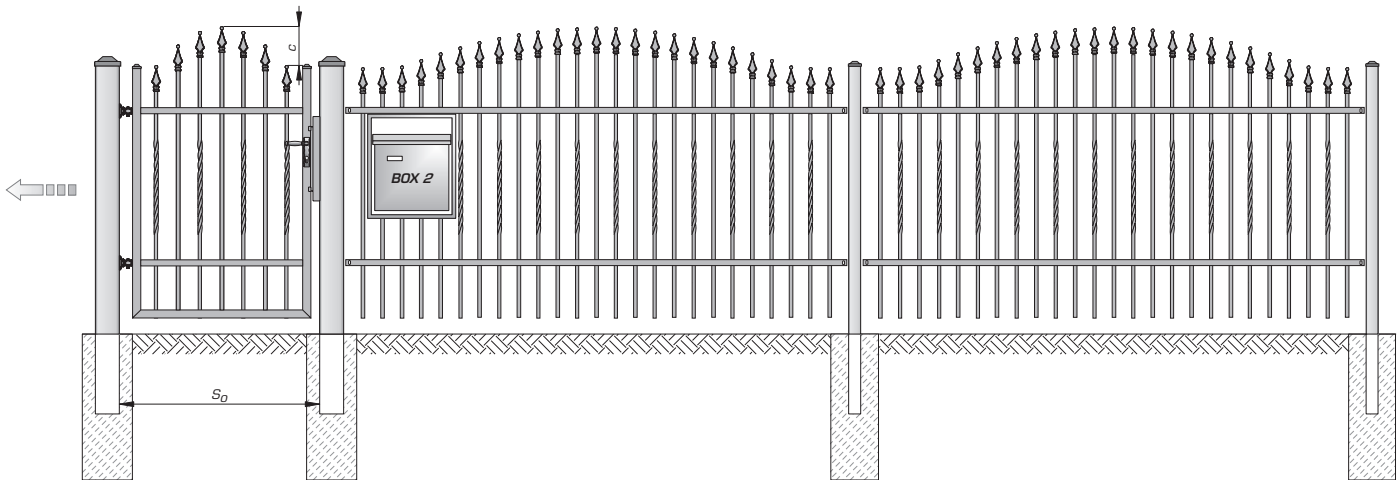
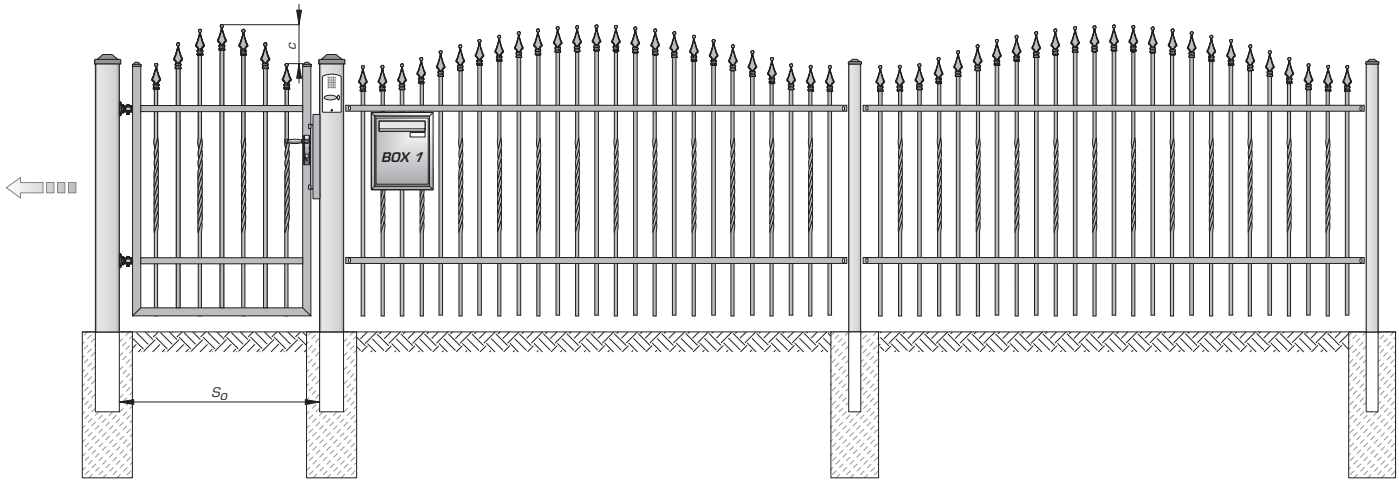

AW.10.46/Wk

(S) 2500 [mm] x (H) 1200 [mm] - 58 kg (S) 2500 [mm] x (H) 1450 [mm] - 69 kg
max: (S) 3000 [mm] x (H) 1750 [mm]

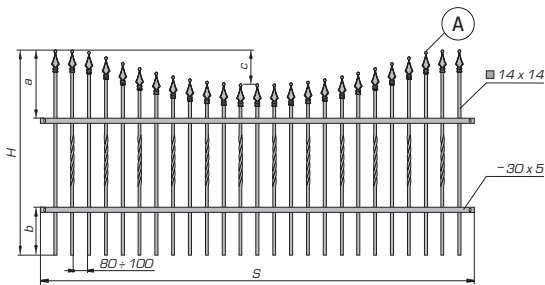

H=1450 : a=400, b=300, c=200, H_{min}=1000 H=1200 : a=400, b=100 ÷ 300, c=200, H_{min}=1000

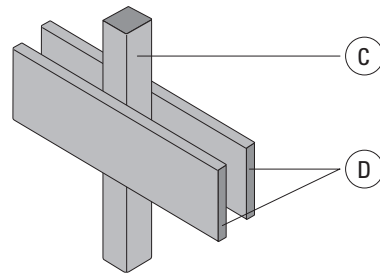

U3 C 14 x 14 D 30 x 5



System Lux
AW.10.48

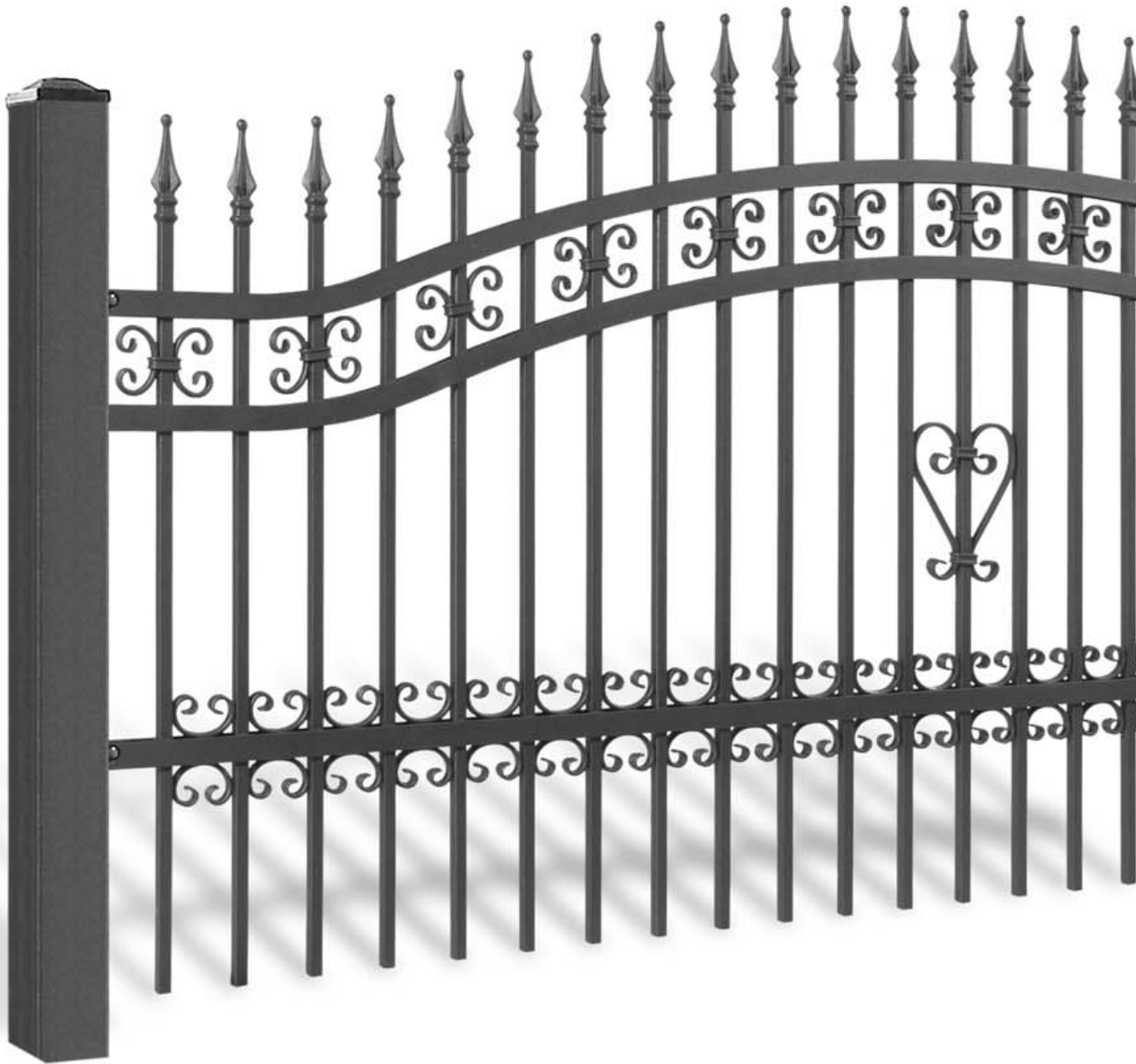

System Łux
AW.10.48



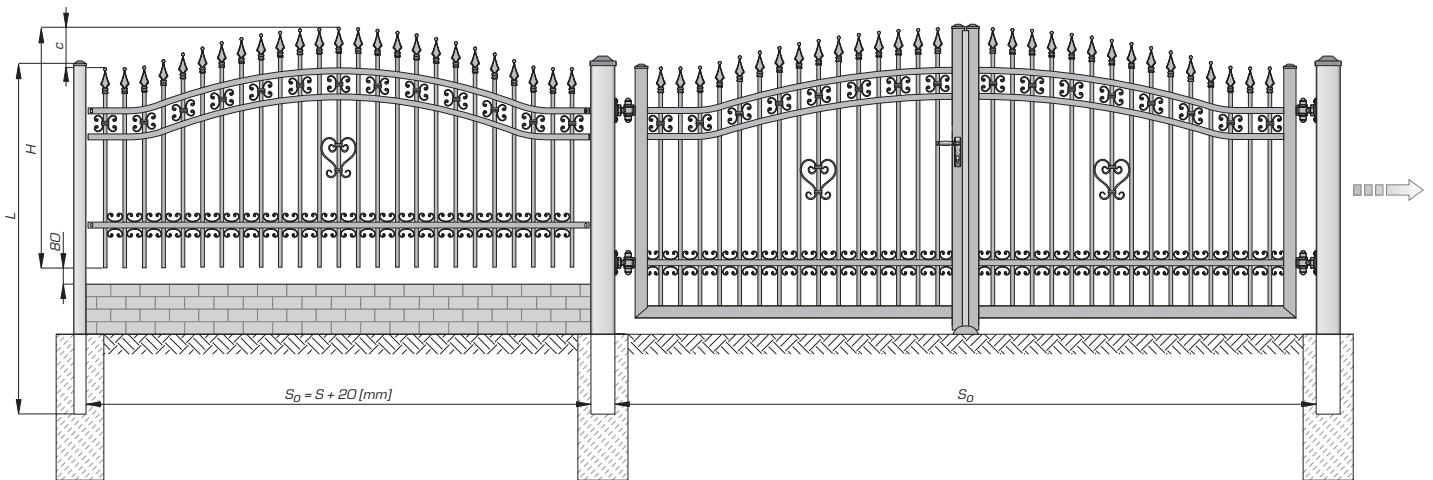
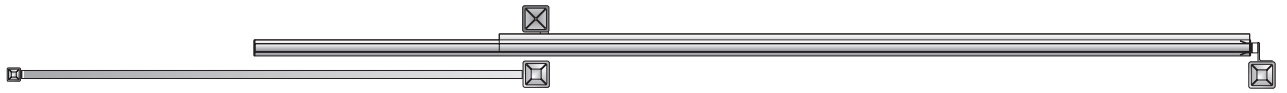
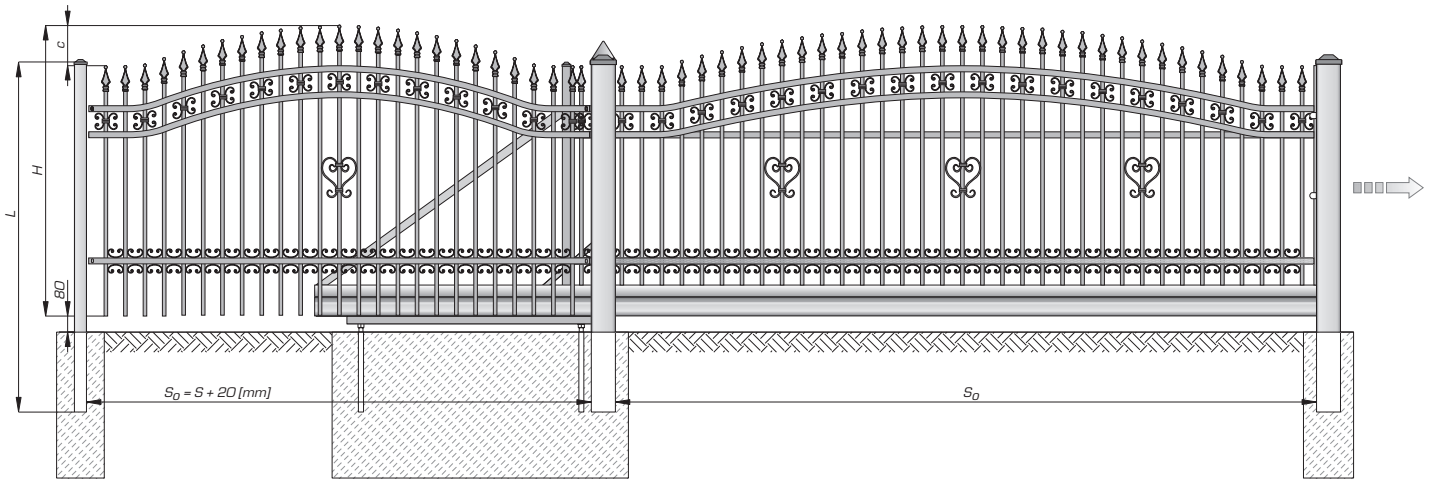

AW.10.48/Wp

(S) 2500 [mm] x (H) 1200 [mm] - 76 kg (S) 2500 [mm] x (H) 1450 [mm] - 86 kg
max: (S) 3000 [mm] x (H) 1750 [mm]

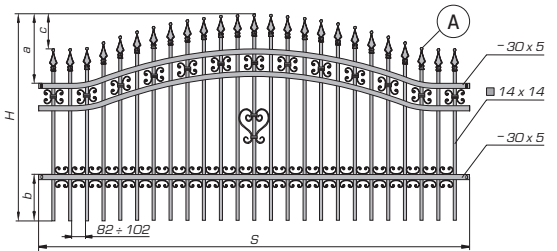

H=1450 : a=400, b=300, c=200, H_{min}=1000 H=1200 : a=400, b=100+300, c=200, H_{min}=1000

AW.10.48/P

(S) 2500 [mm] x (H) 1200 [mm] - 79 kg (S) 2500 [mm] x (H) 1450 [mm] - 89 kg
max: (S) 3000 [mm] x (H) 1750 [mm]

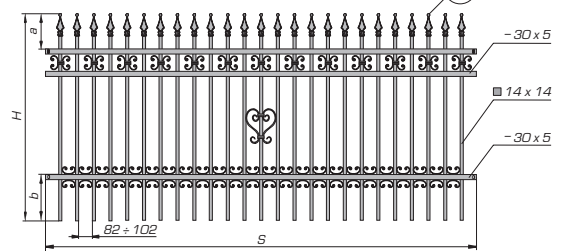

H=1450 : a=250, b=300, H_{min}=1000 H=1200 : a=250, b=100+300, H_{min}=1000

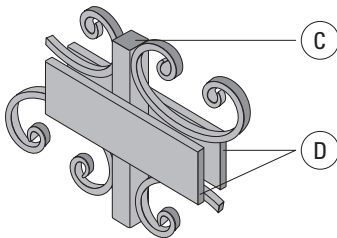
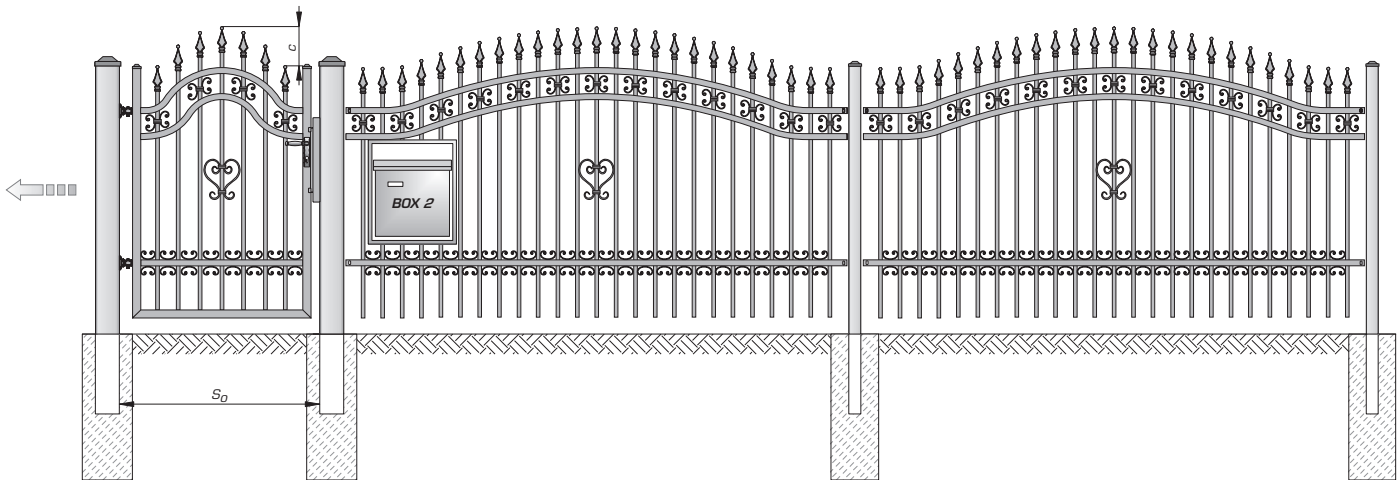
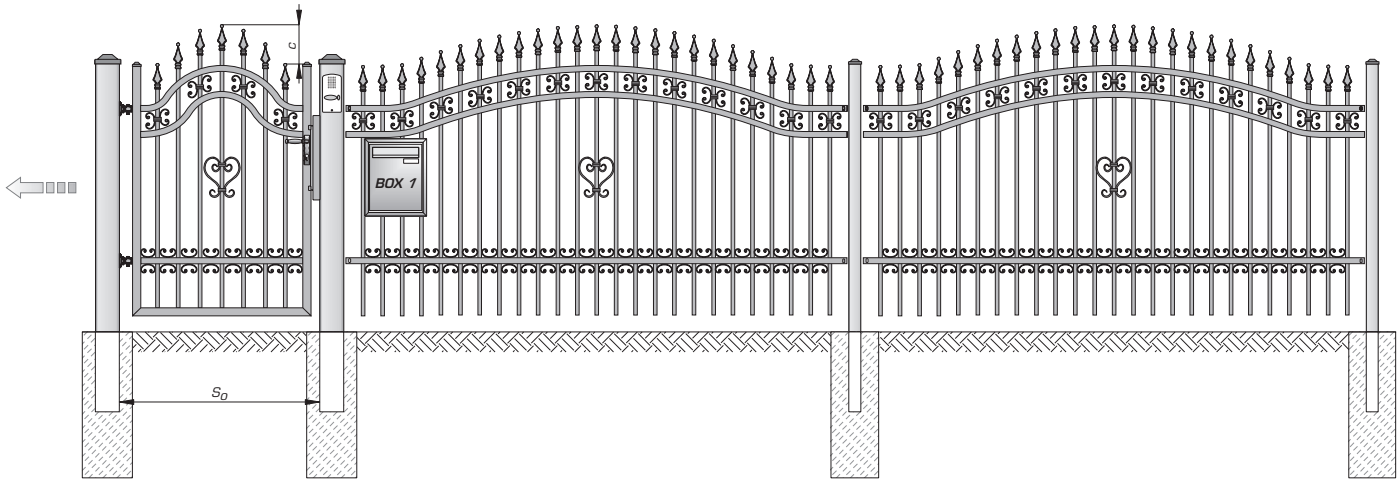

C

D

U3

C 14 x 14

D 30 x 5

AW.10.48/Wp

AW.10.48/Wp

AW.10.48/P

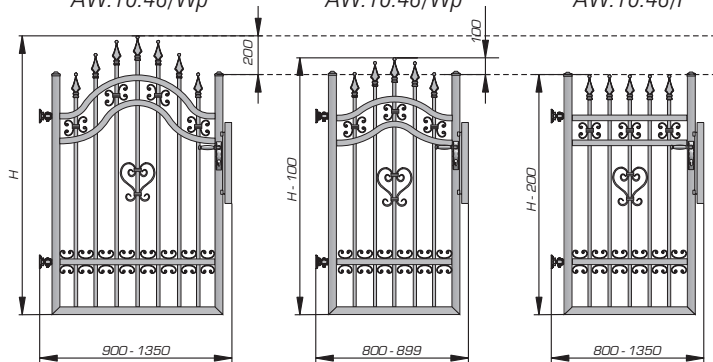

- PL** / Zmiana wysokości futki w zależności od szerokości
- EN** / Change of wicket height depending on its width
- DE** / Änderung der Pforteshöhe abhängig von Breite
- RU** / Изменение высоты калитки в зависимости от ширины



System **Lox**
AW.10.52

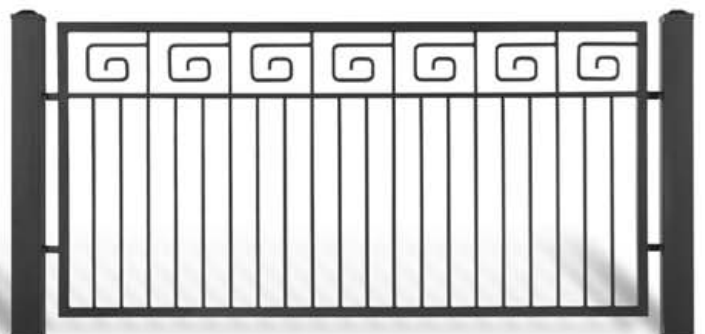
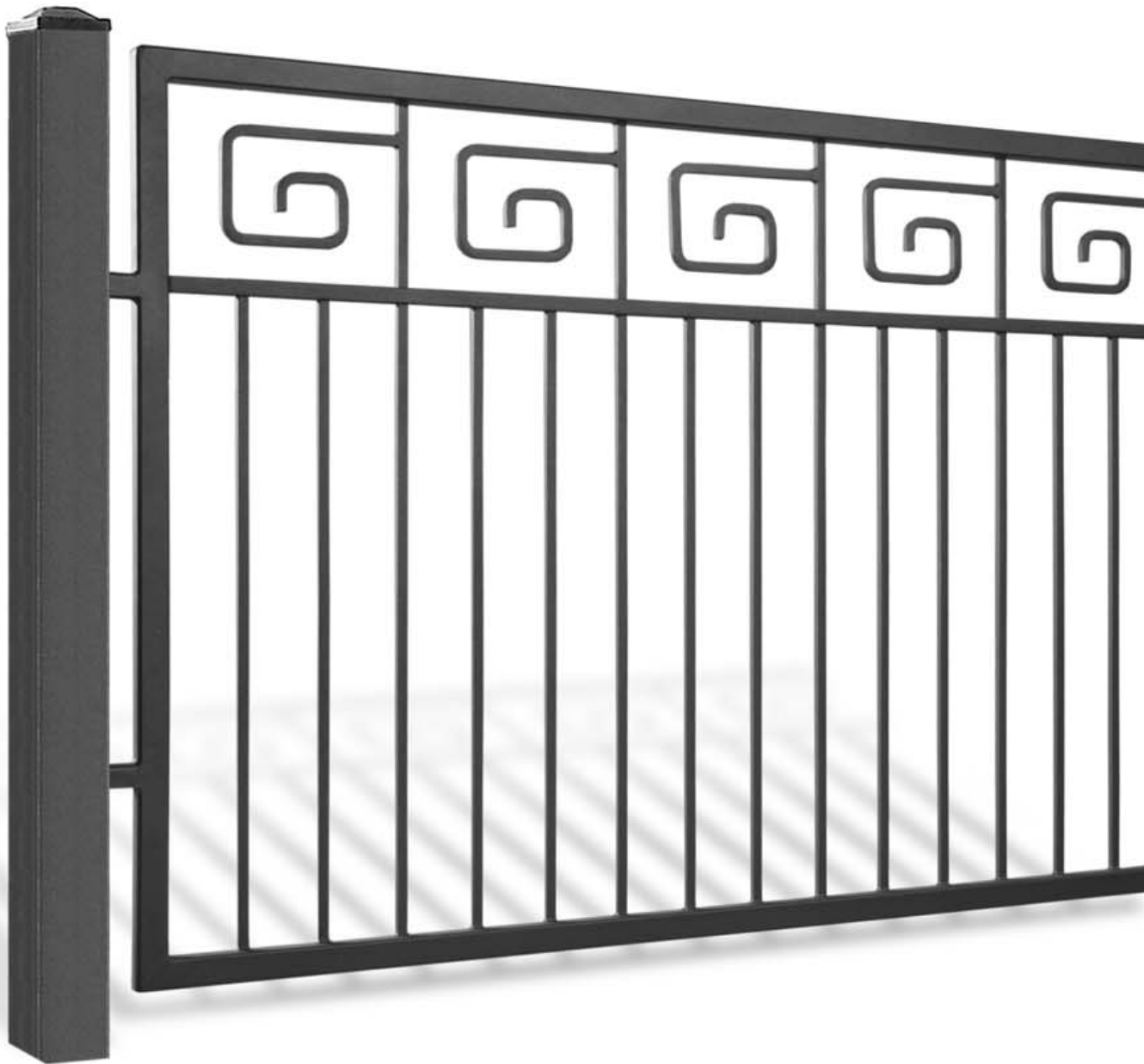

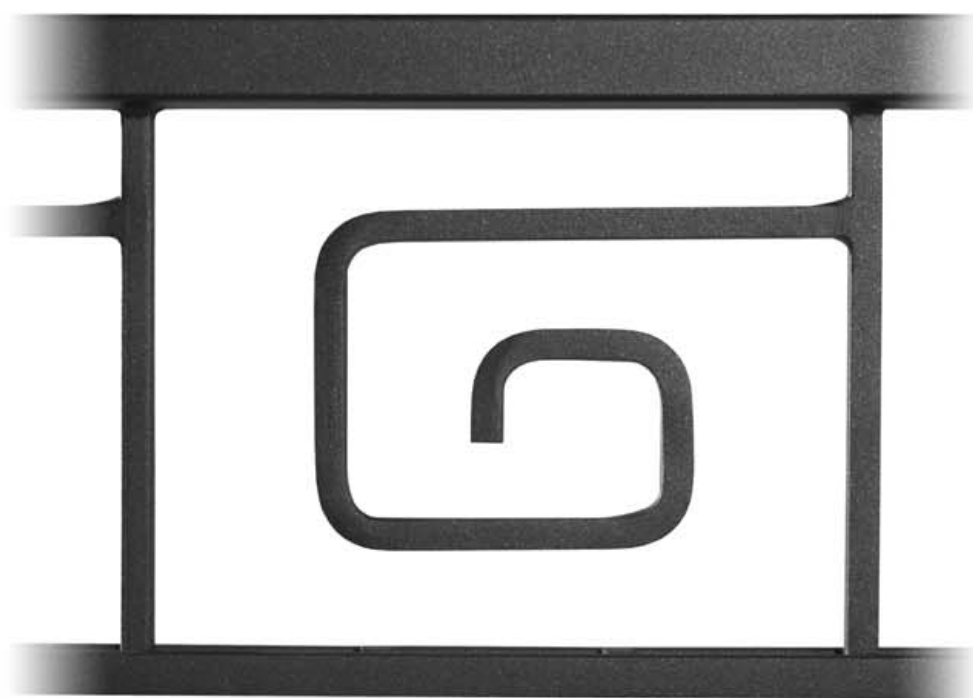

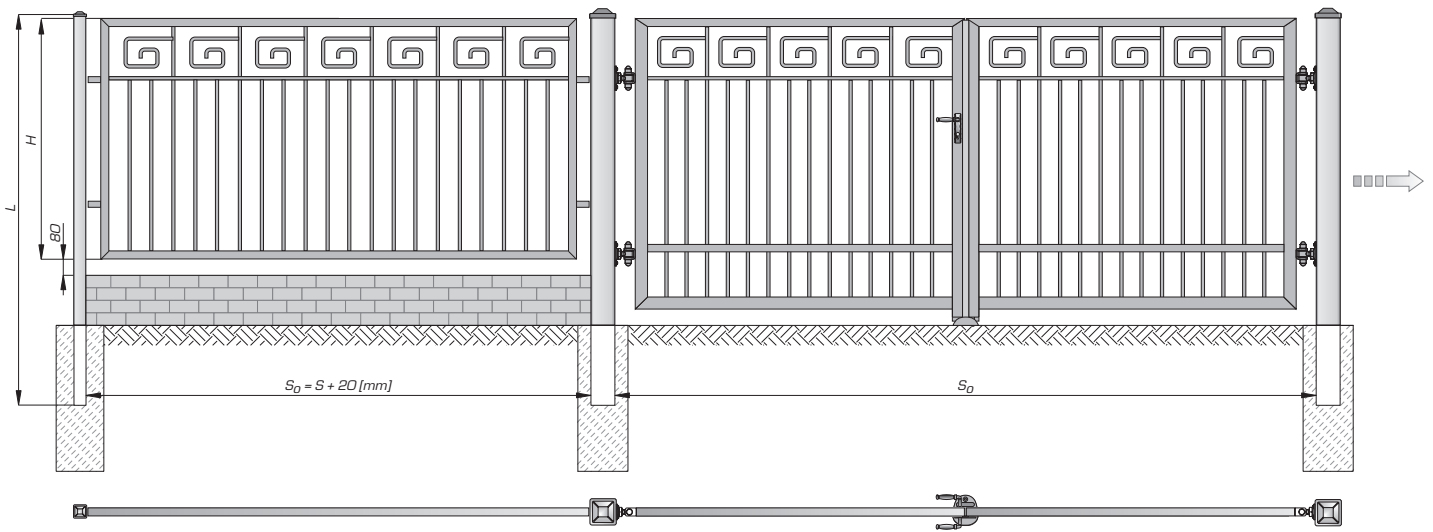
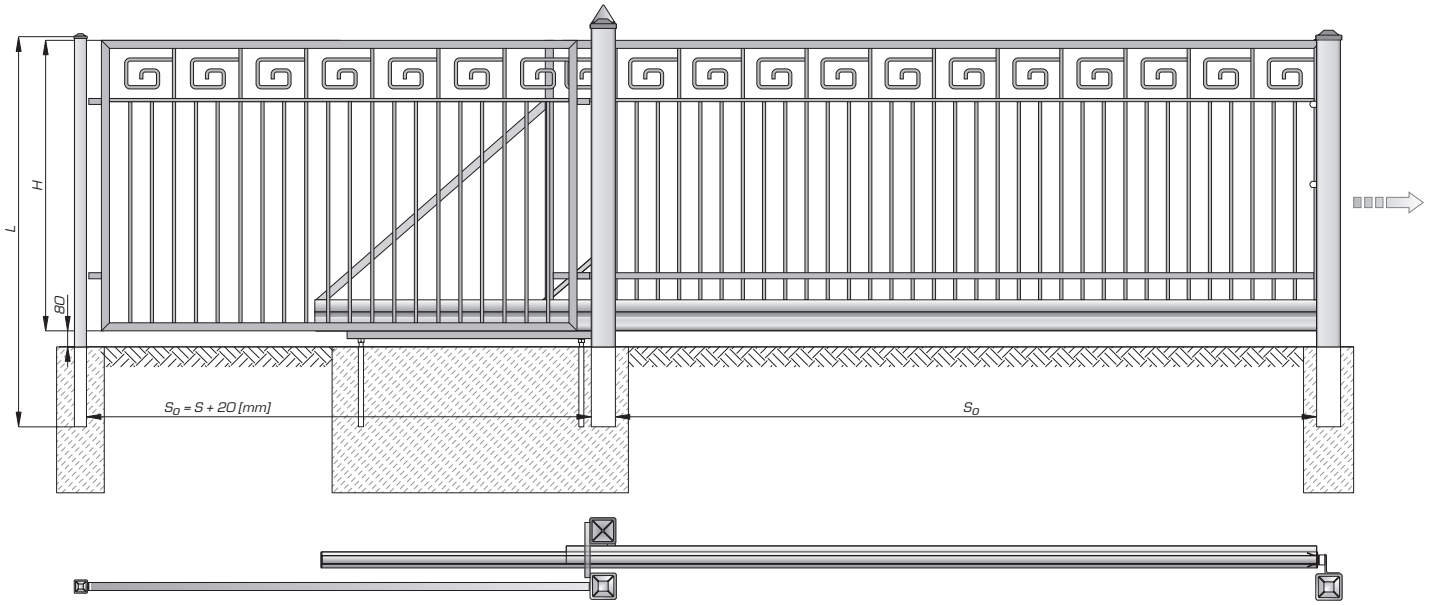

AW.10.52/P

(S) 2500 [mm] x (H) 900 [mm] - 56 kg	(S) 2500 [mm] x (H) 1450 [mm] - 78 kg
(S) 2500 [mm] x (H) 1200 [mm] - 67 kg	
max: (S) 3000 [mm] x (H) 1750 [mm]	

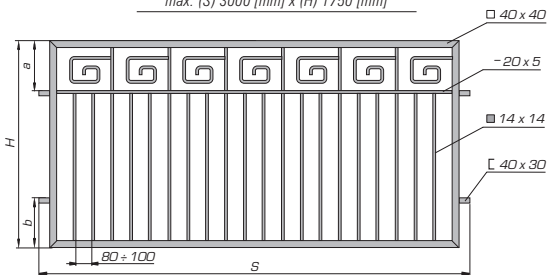

H=1450 : a=290, b=300, H _{min} =800	H=1200 : a=290, b=300, H _{min} =800
--	--

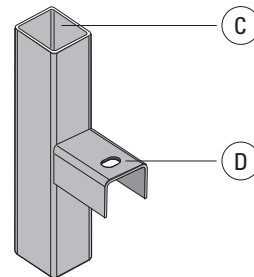

U4 C 40x40 D 40x30

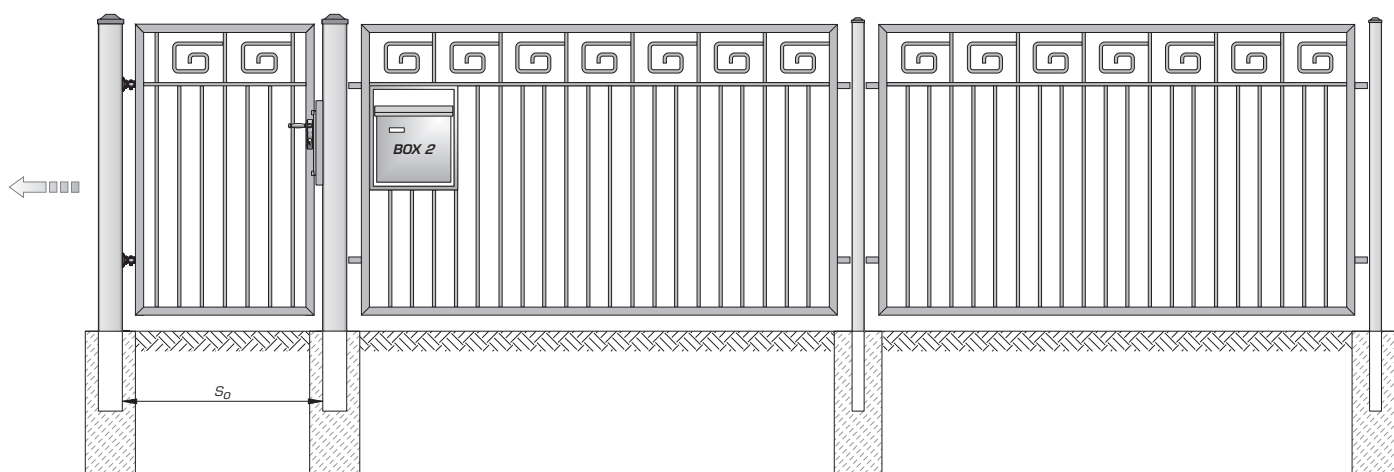
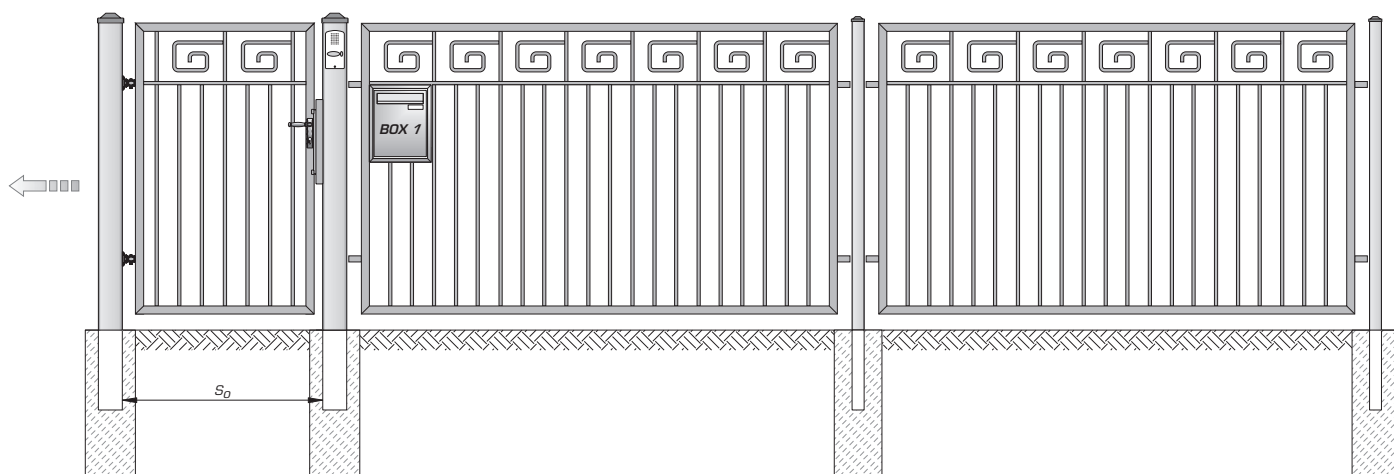



System Lux
AW.10.53

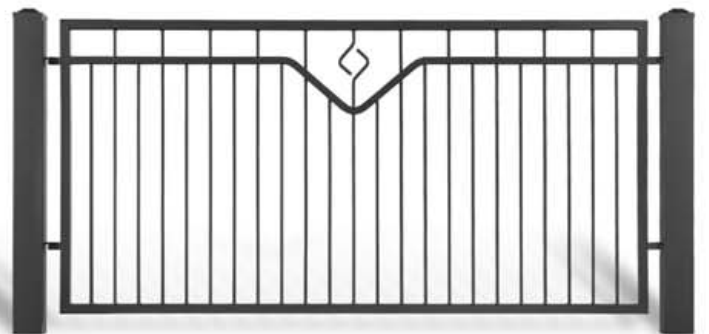

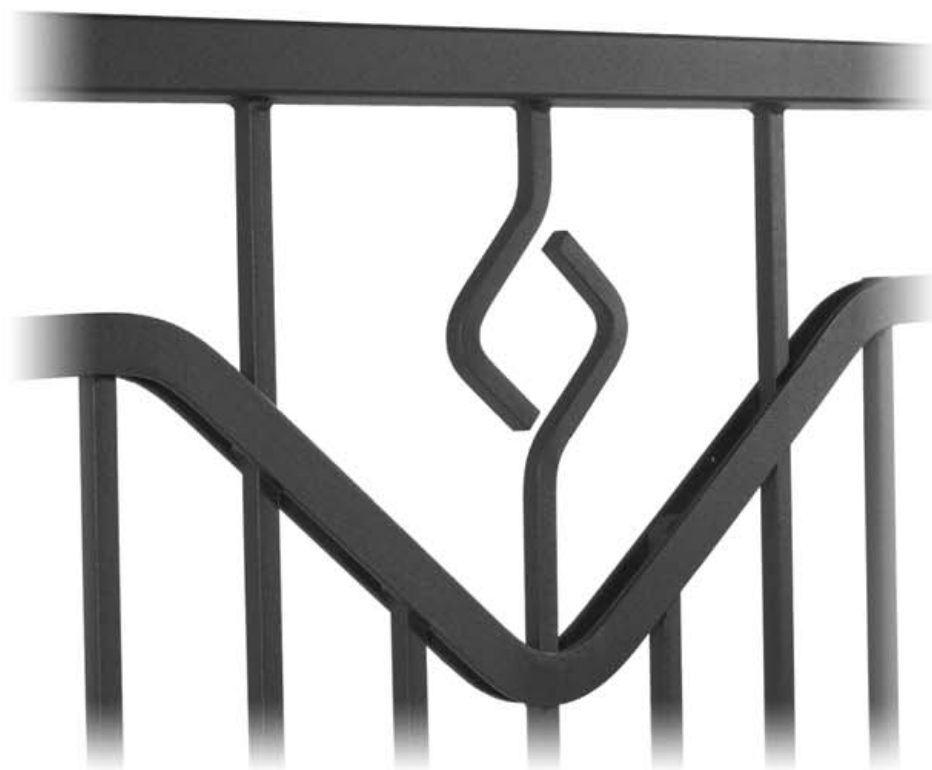

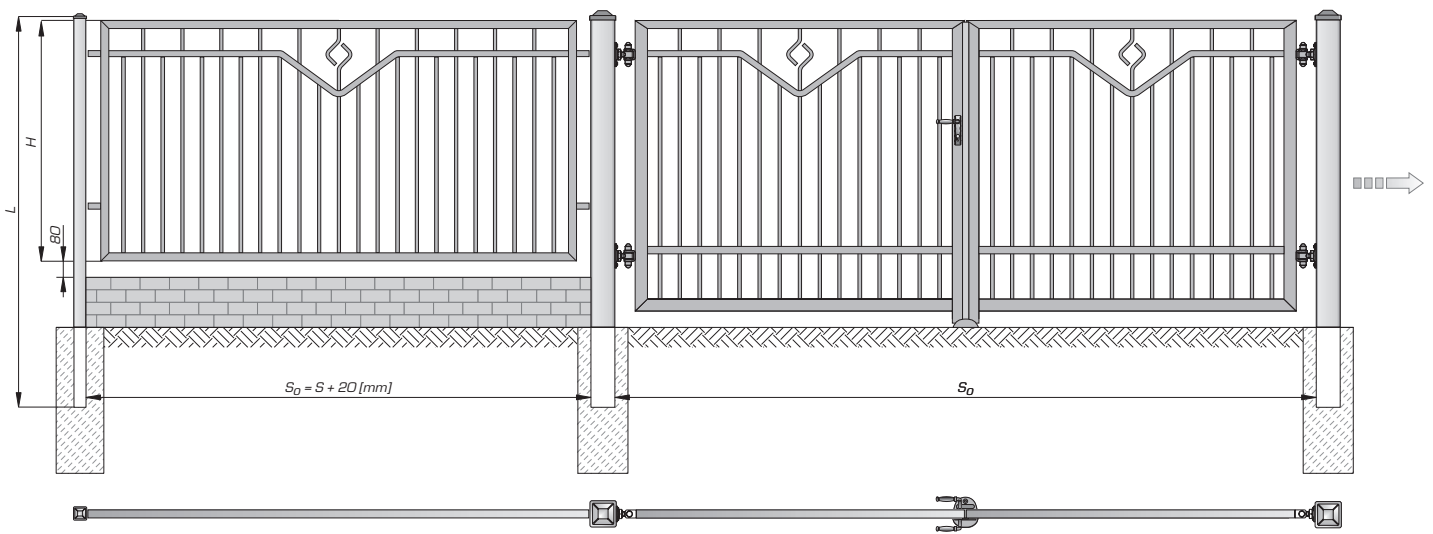
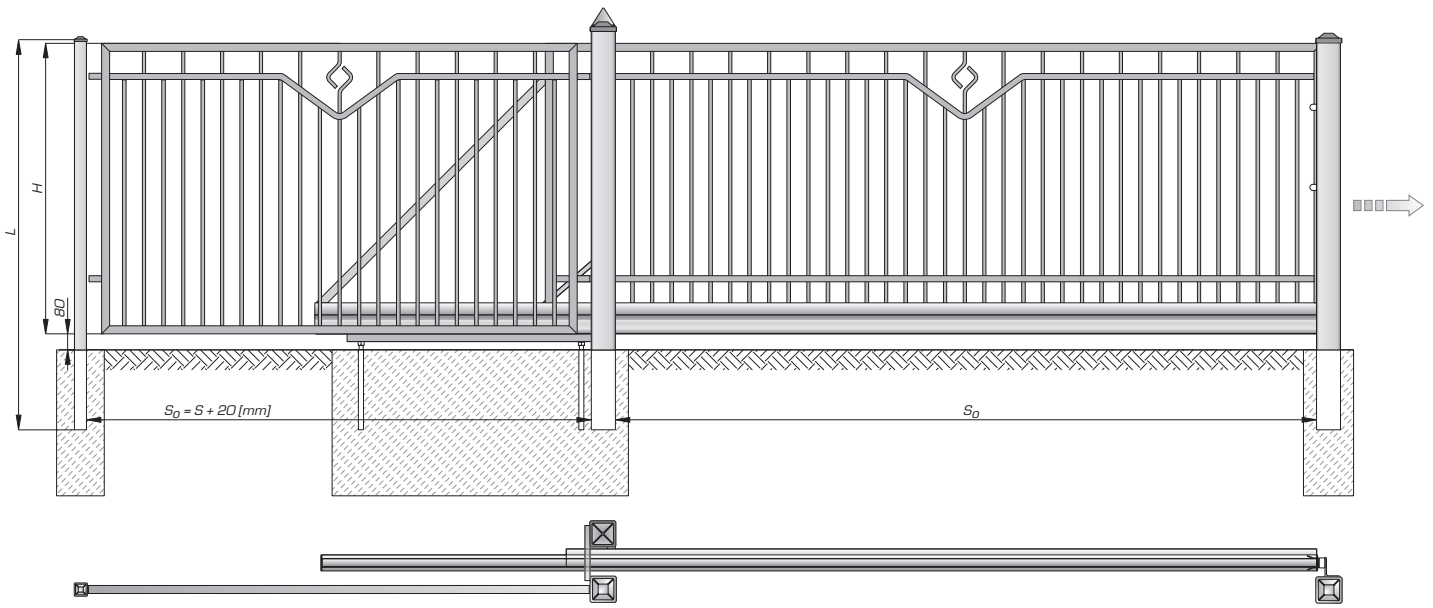

AW.10.53/P

- (S) 2500 [mm] x (H) 900 [mm] - 58 kg
- (S) 2500 [mm] x (H) 1200 [mm] - 69 kg
- (S) 2500 [mm] x (H) 1450 [mm] - 80 kg
- max: (S) 3000 [mm] x (H) 1750 [mm]

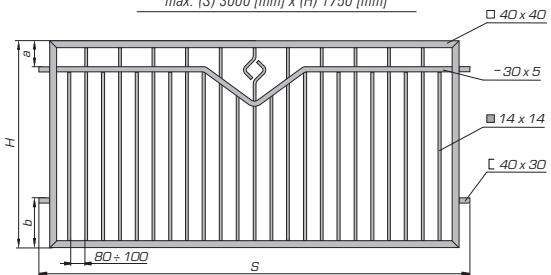

H=1450 : a=150, b=300, H_{min}=800

H=1200 : a=150, b=300, H_{min}=800

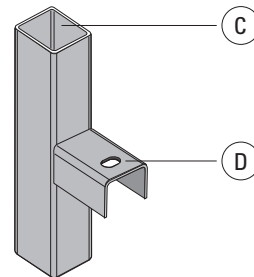

U4 C 40x40 D 40x30

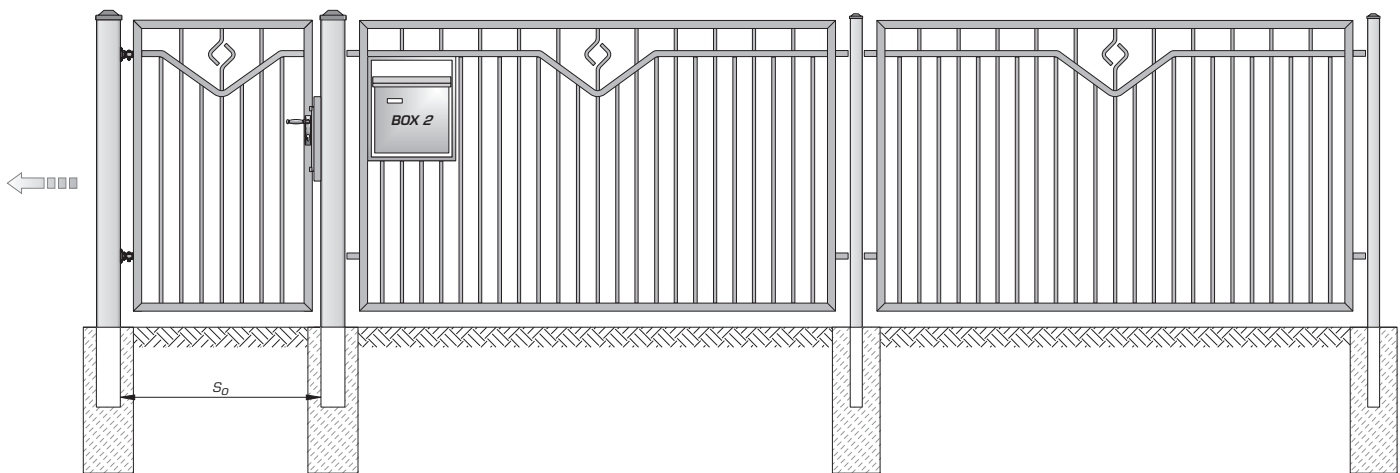
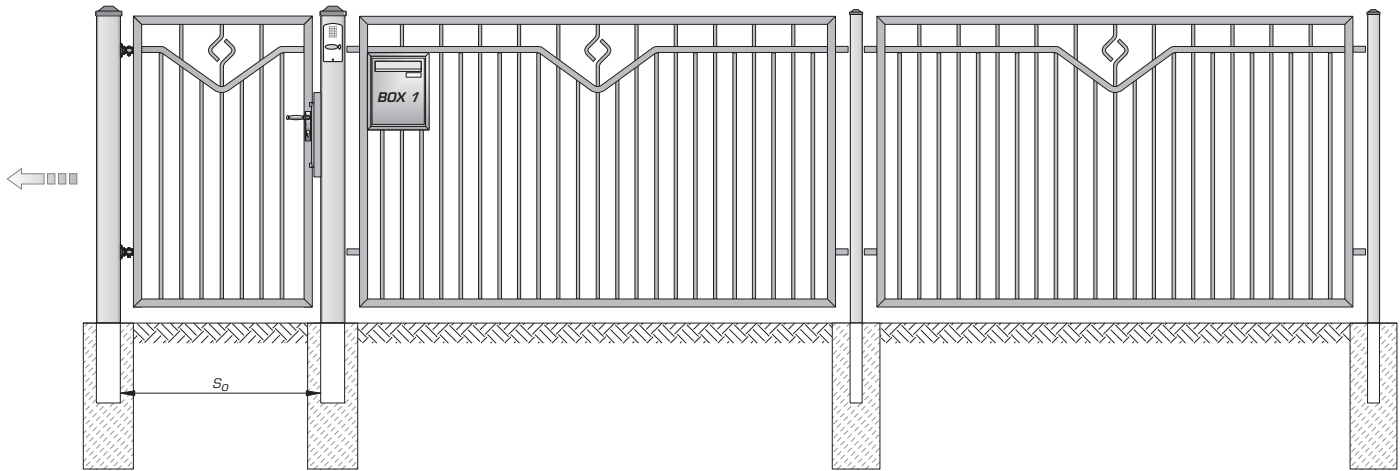



System **Lox**
AW.10.56

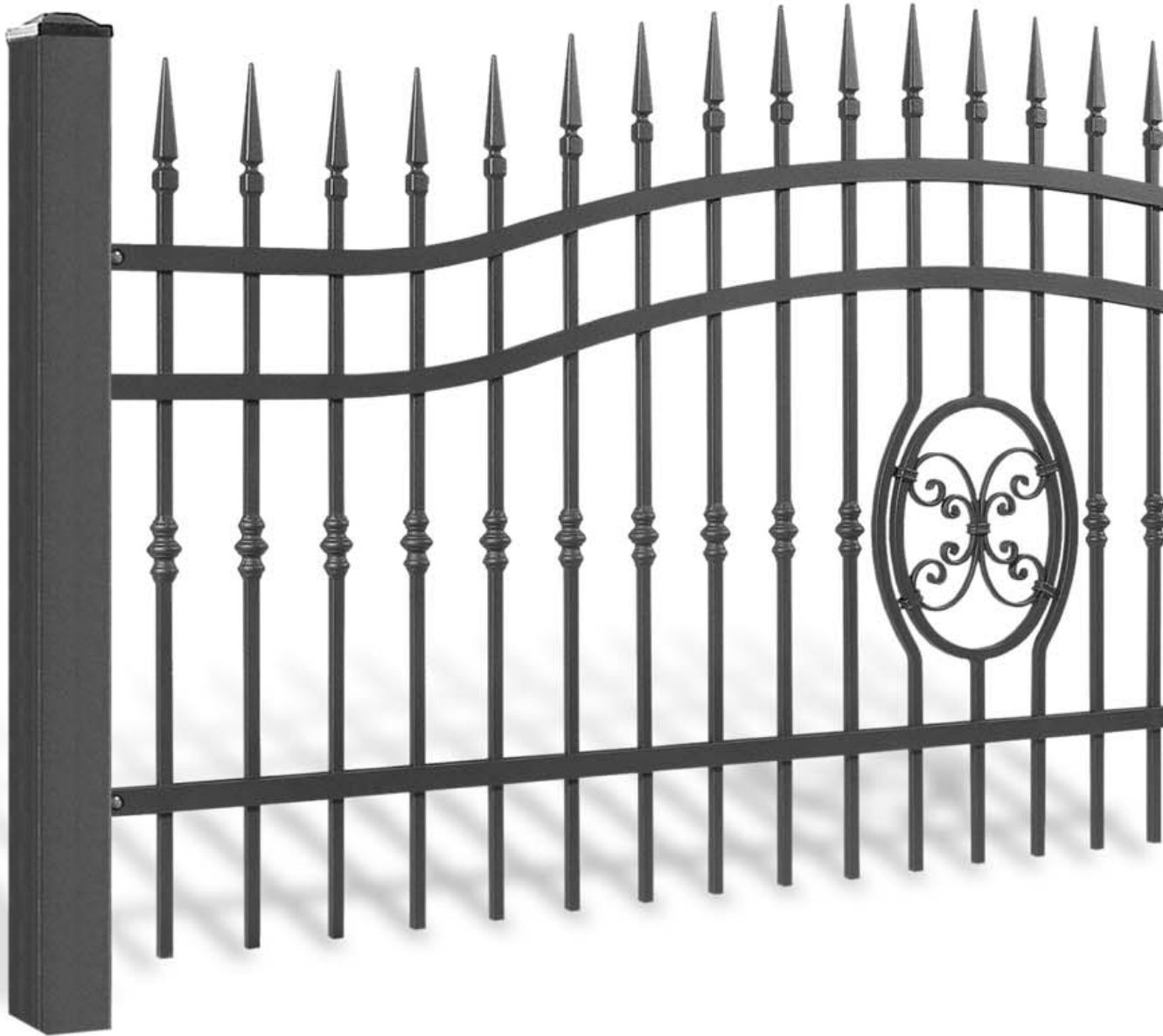

System Łux
AW.10.56

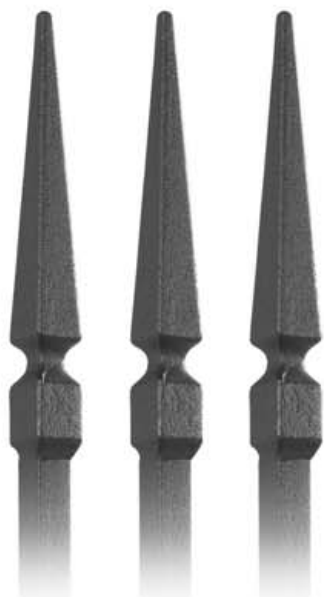

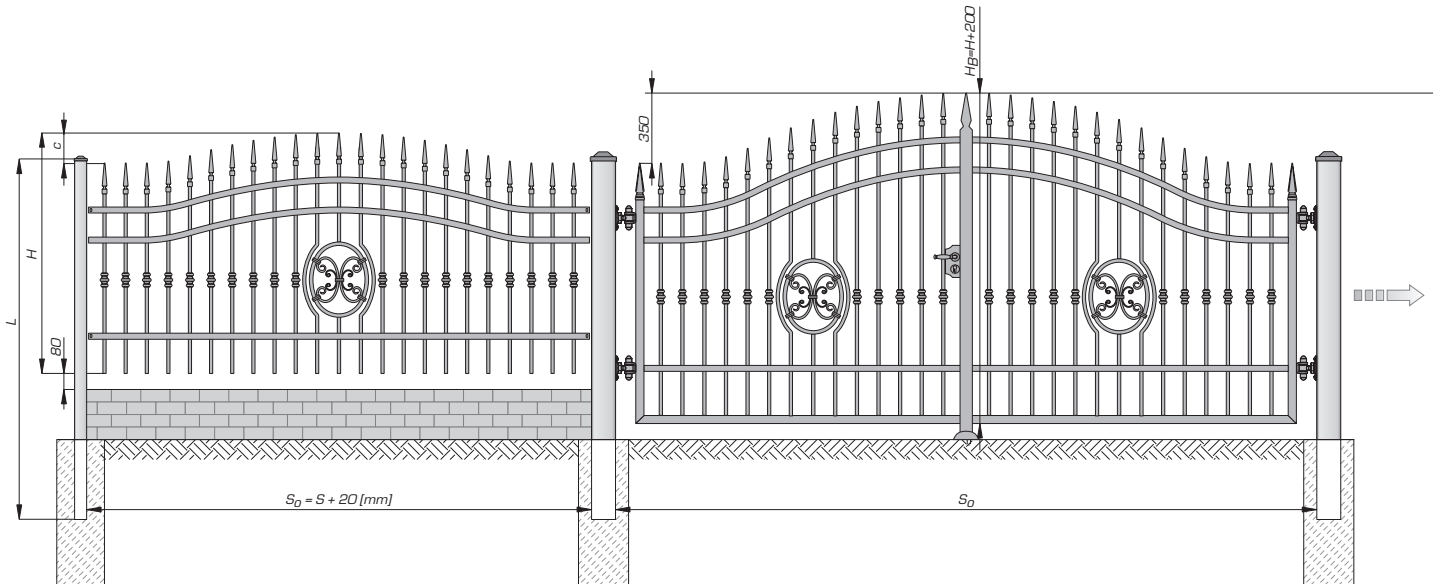
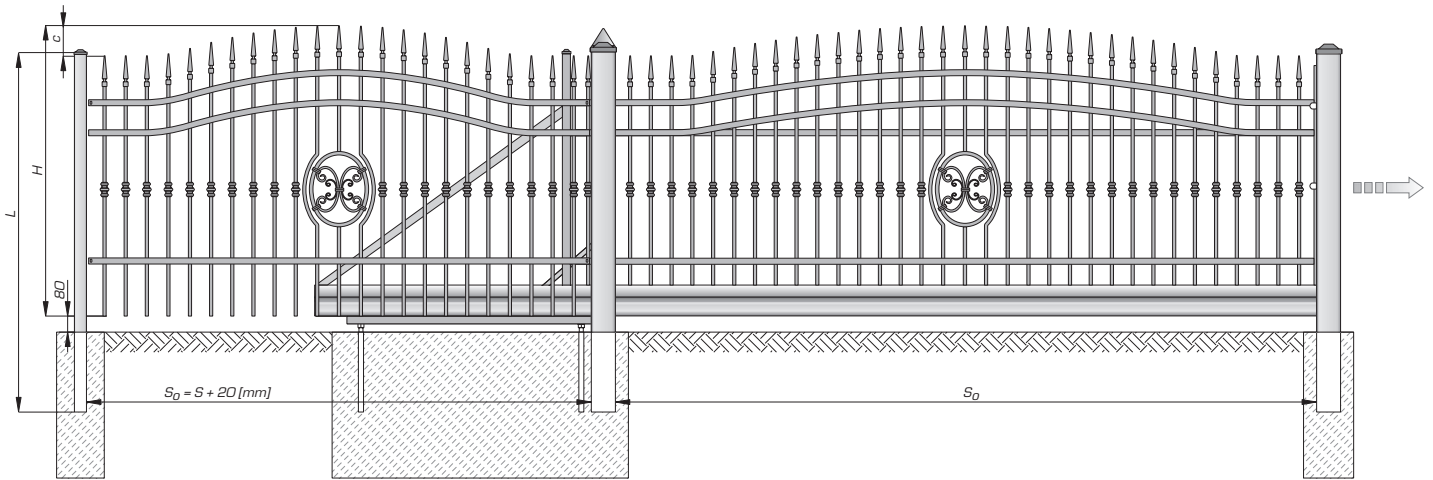

AW.10.56/Wp

(S) 2500 [mm] x (H) 1200 [mm] - 79 kg (S) 2500 [mm] x (H) 1450 [mm] - 90 kg
 max: (S) 3000 [mm] x (H) 1750 [mm]

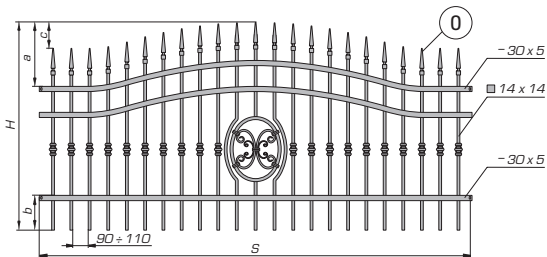

H=1450 : a=370, b=300, c=150, H_{min}=1150 H=1200 : a=370, b=100 ÷ 300, c=150, H_{min}=1150

AW.10.56/P

(S) 2500 [mm] x (H) 1200 [mm] - 82 kg (S) 2500 [mm] x (H) 1450 [mm] - 93 kg
 max: (S) 3000 [mm] x (H) 1750 [mm]

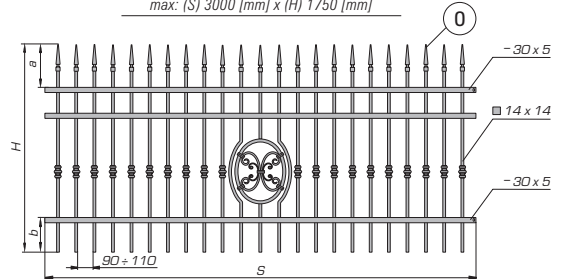

H=1450 : a=220, b=300, H_{min}=1000 H=1200 : a=220, b=100 ÷ 300, H_{min}=1000

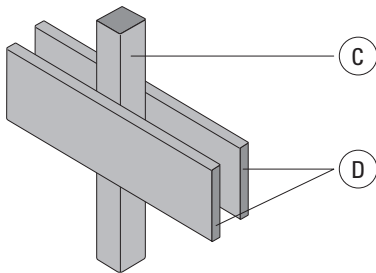
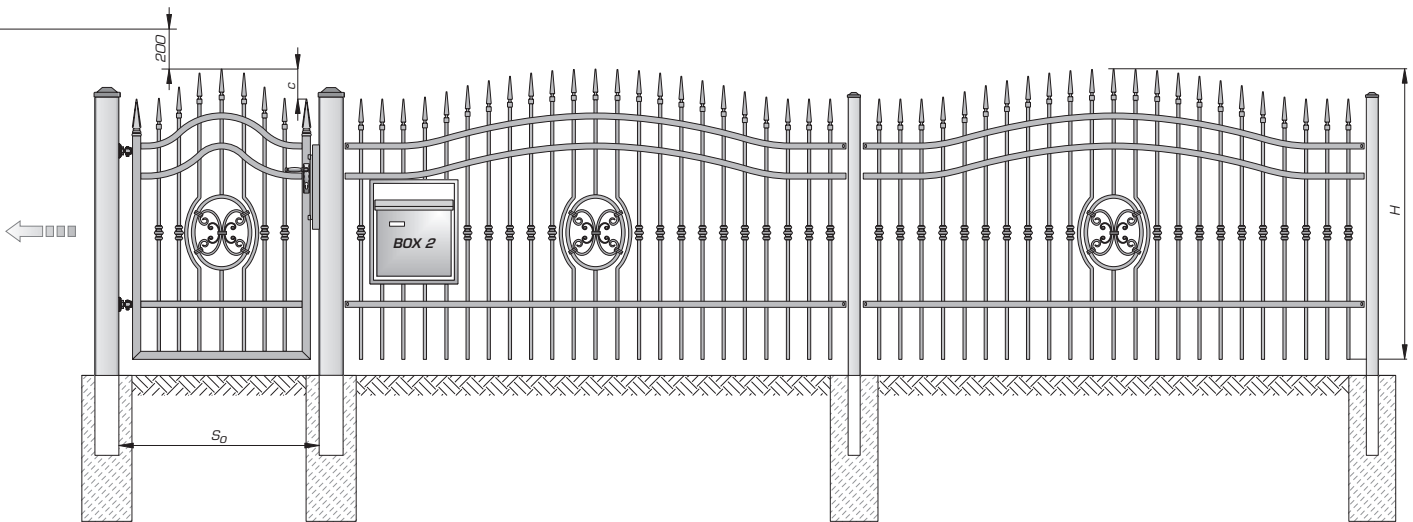
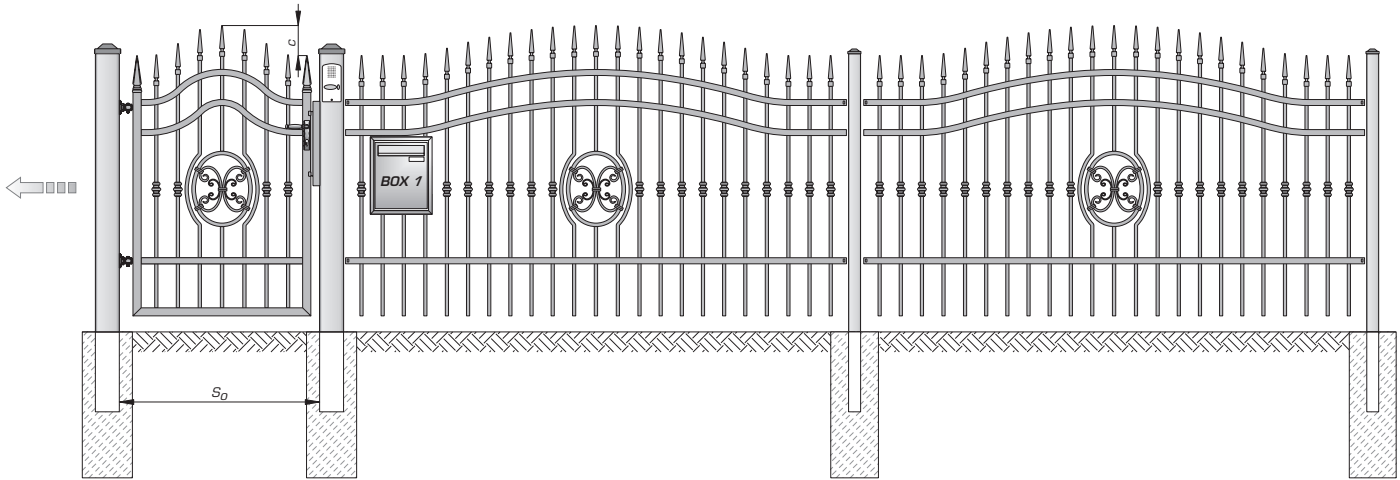

U3 **C** 14 x 14 **D** 30 x 5



System **Lox**
AW.10.57

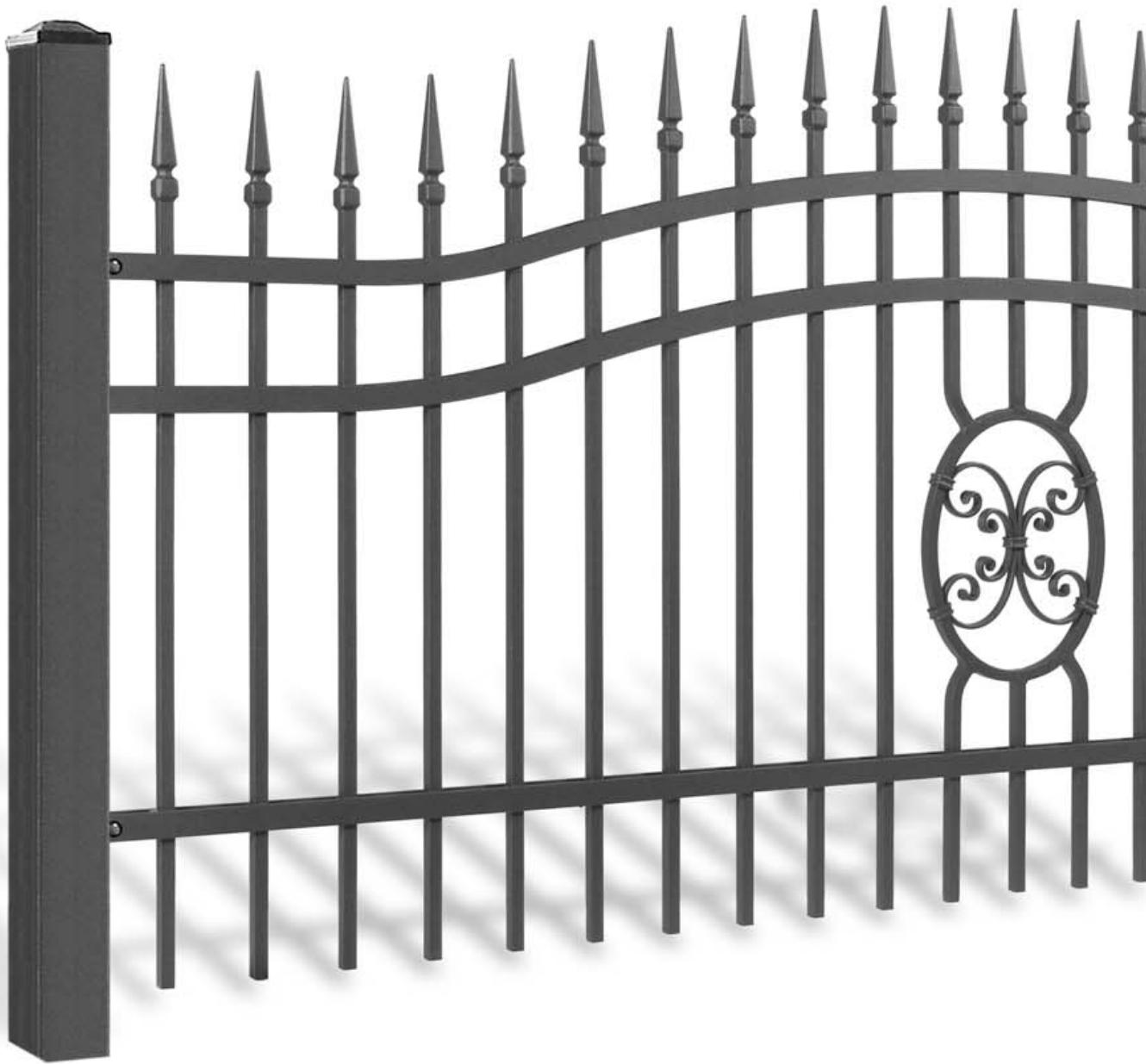

System Łoux
AW.10.57

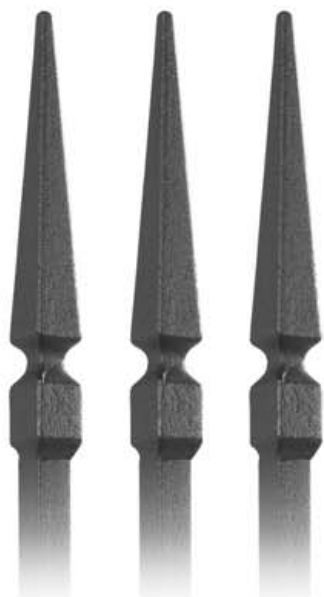

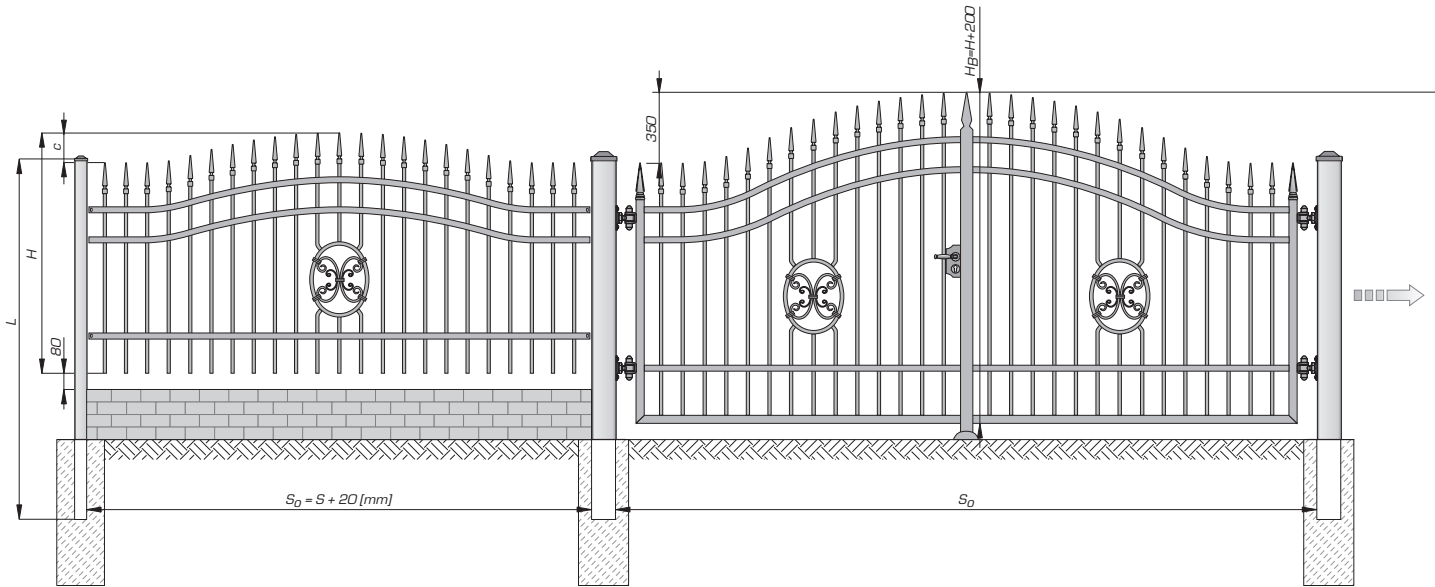
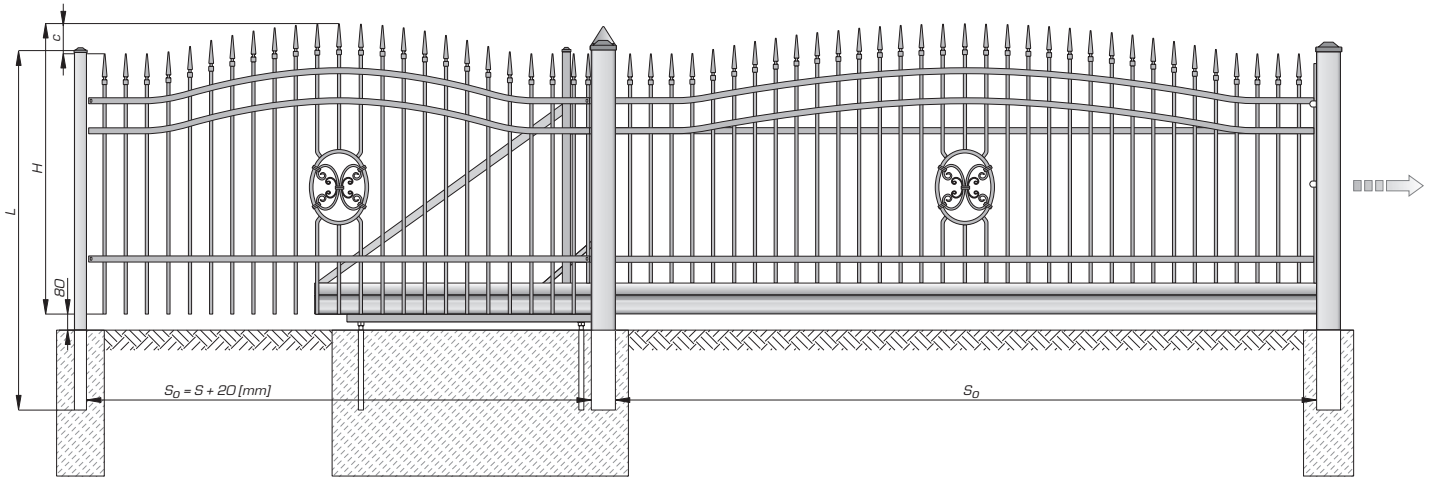

AW.10.57/Wp

(S) 2500 [mm] x (H) 1200 [mm] - 70 kg (S) 2500 [mm] x (H) 1450 [mm] - 80 kg
max: (S) 3000 [mm] x (H) 1750 [mm]

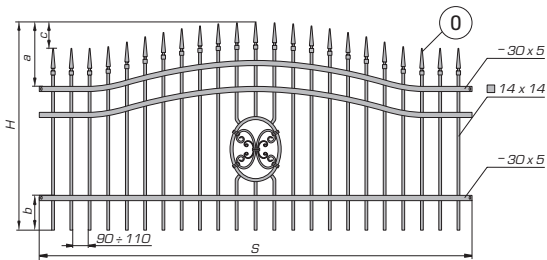

H=1450 : a=370, b=300, c=150, H_{min}=1150 H=1200 : a=370, b=100 ÷ 300, c=150, H_{min}=1150

AW.10.57/P

(S) 2500 [mm] x (H) 1200 [mm] - 73 kg (S) 2500 [mm] x (H) 1450 [mm] - 83 kg
max: (S) 3000 [mm] x (H) 1750 [mm]

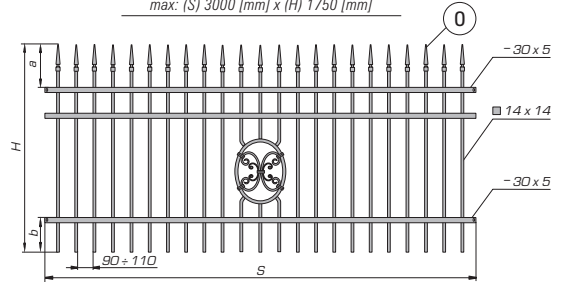

H=1450 : a=220, b=300, H_{min}=1000 H=1200 : a=220, b=100 ÷ 300, H_{min}=1000

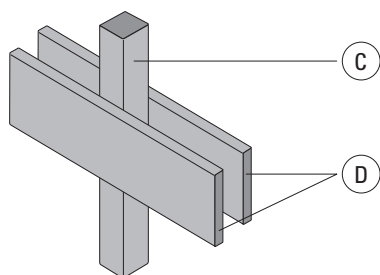
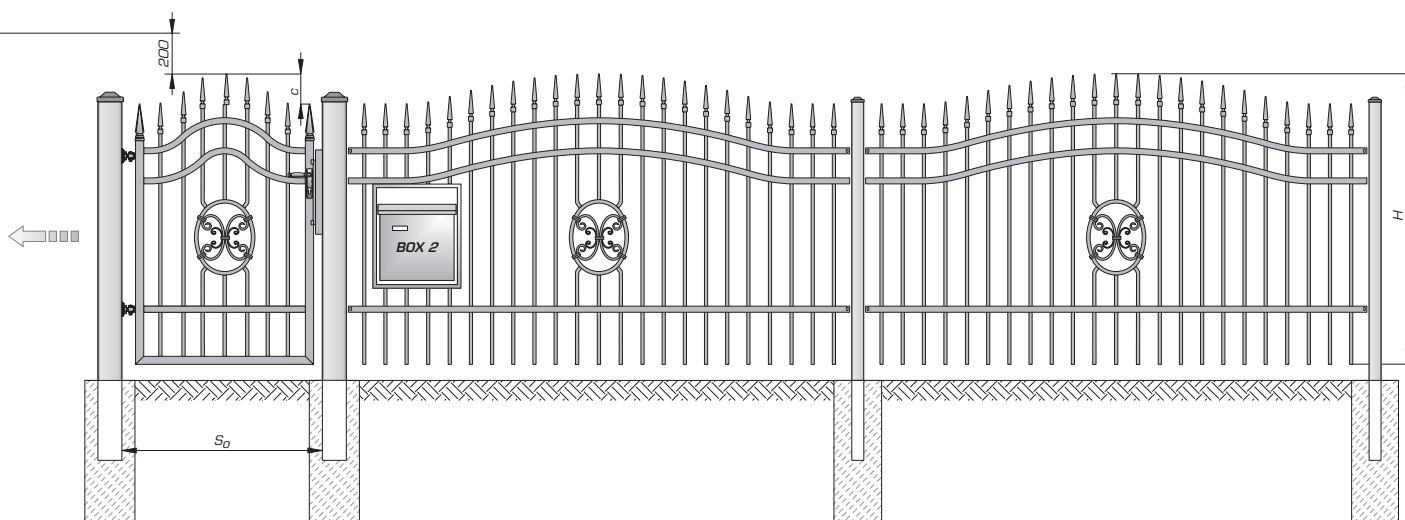
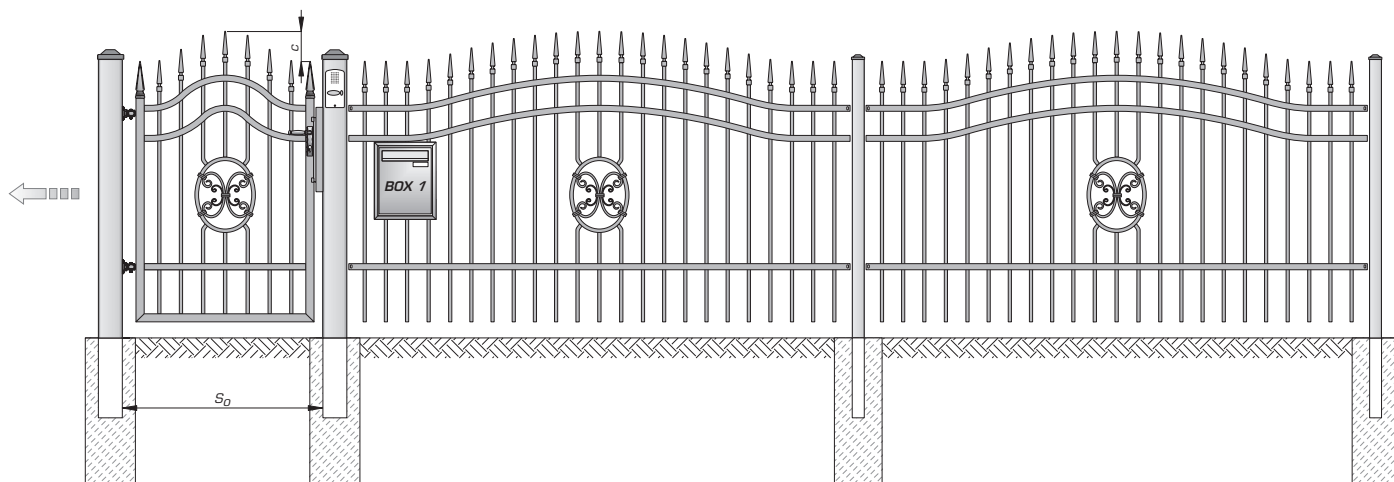

U3 C 14 x 14 D 30 x 5



System **Lox**
AW.10.58

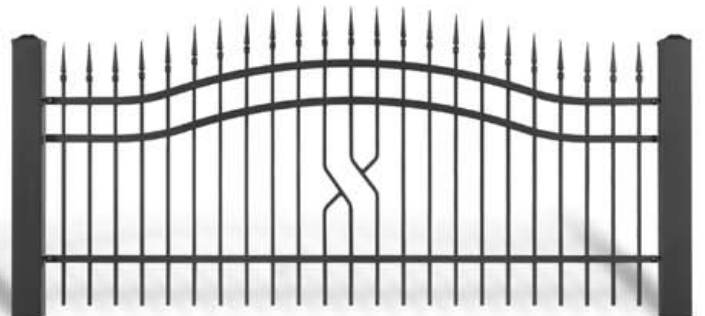
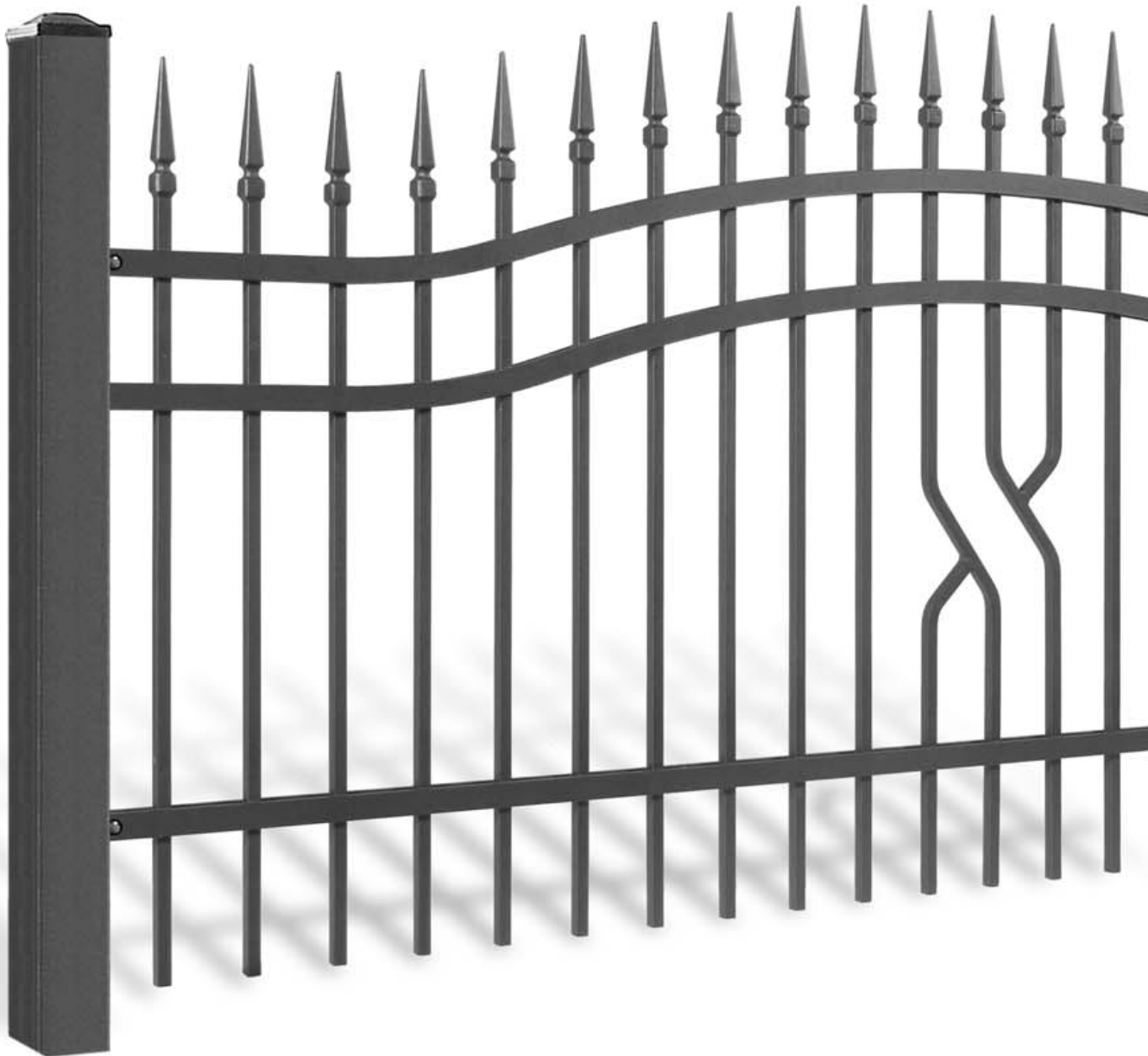

System Ł&X
AW.10.58

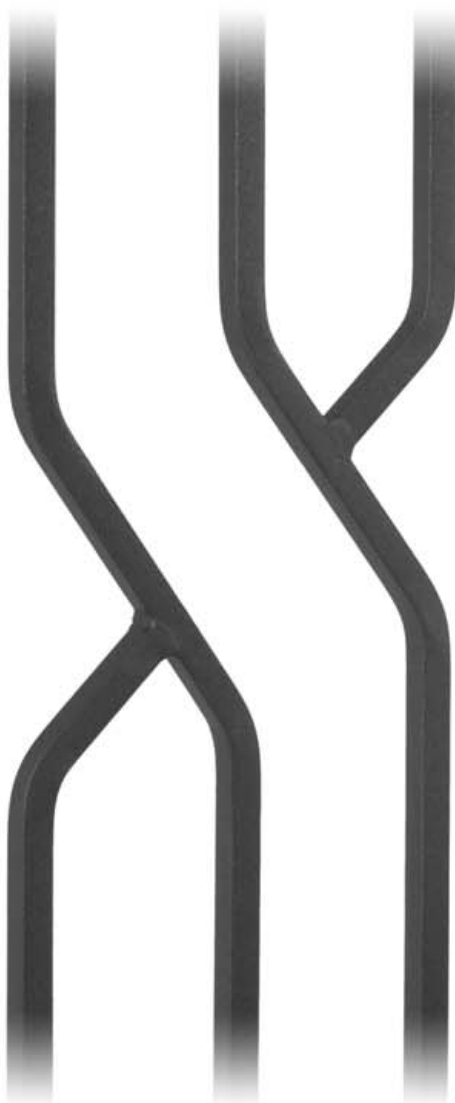

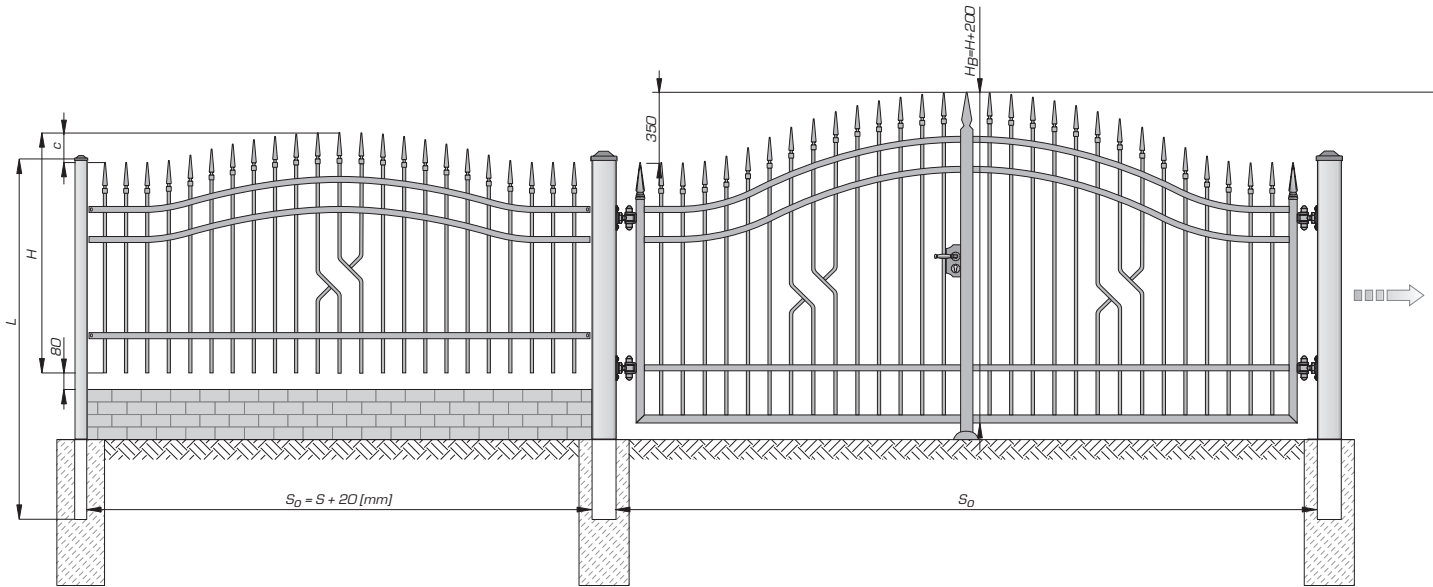
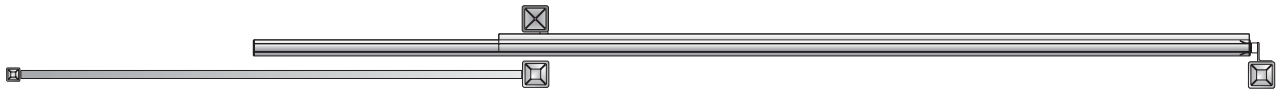
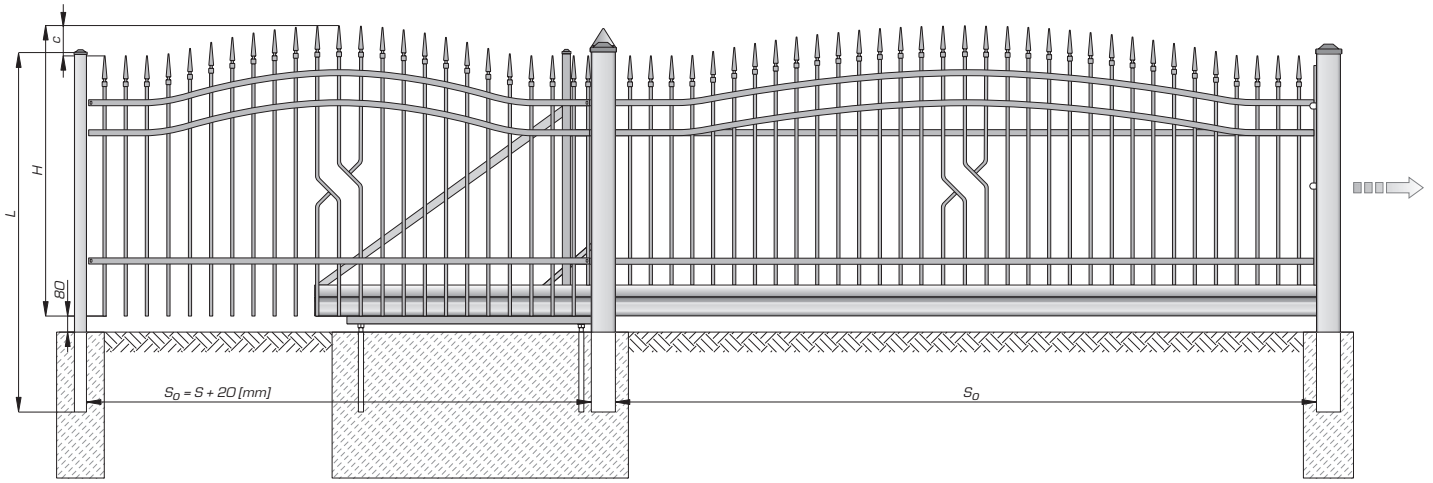

AW.10.58/Wp

(S) 2500 [mm] x (H) 1200 [mm] - 69 kg (S) 2500 [mm] x (H) 1450 [mm] - 79 kg
 max: (S) 3000 [mm] x (H) 1750 [mm]

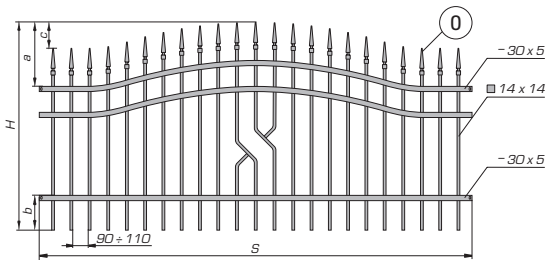

H=1450 : a=370, b=300, c=150, H_{min}=1150 H=1200 : a=370, b=100÷300, c=150, H_{min}=1150

AW.10.58/P

(S) 2500 [mm] x (H) 1200 [mm] - 72 kg (S) 2500 [mm] x (H) 1450 [mm] - 82 kg
 max: (S) 3000 [mm] x (H) 1750 [mm]

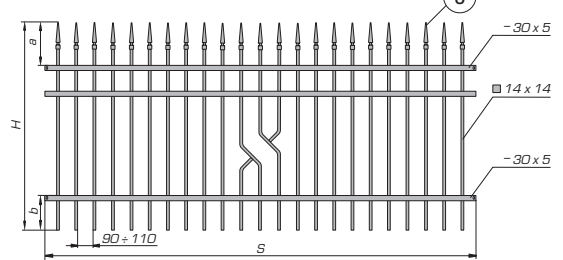

H=1450 : a=220, b=300, H_{min}=1000 H=1200 : a=220, b=100÷300, H_{min}=1000

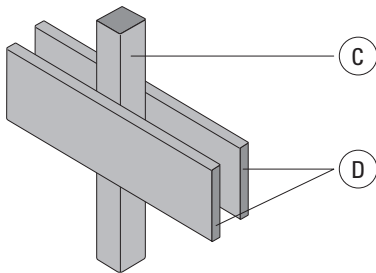
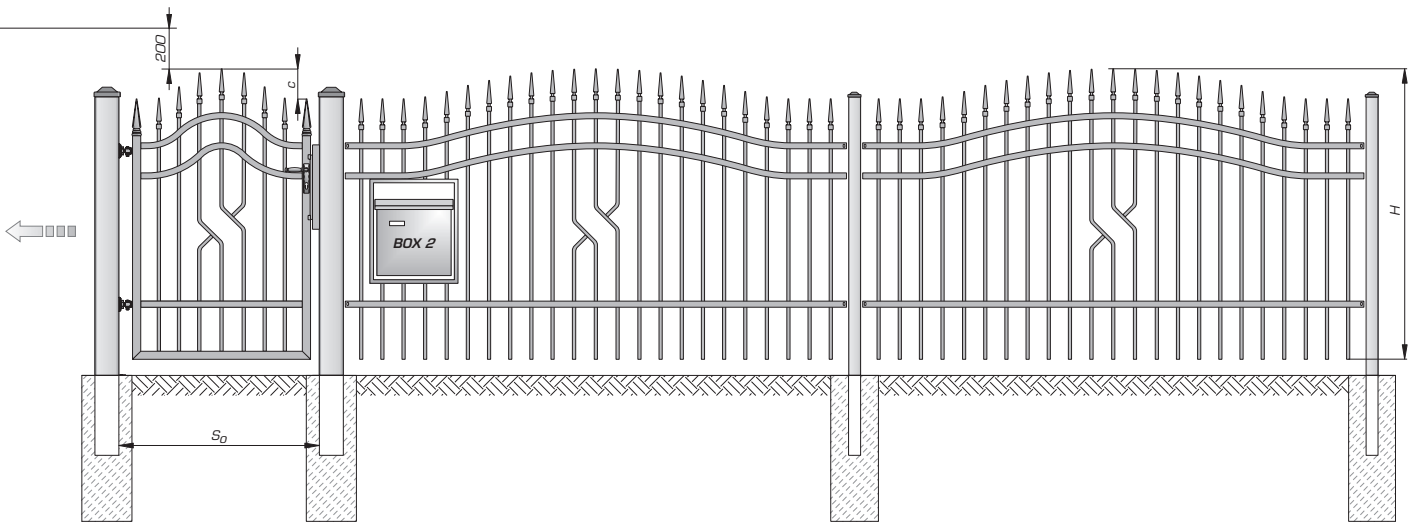
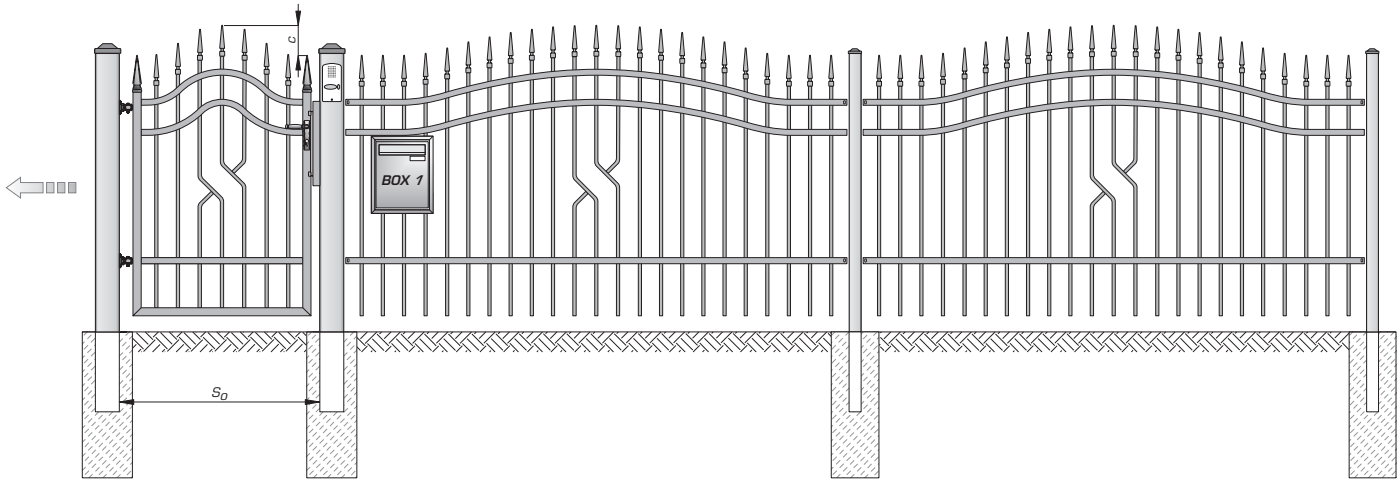

U3 **C** 14 x 14 **D** 30 x 5



System Lux
AW.10.59

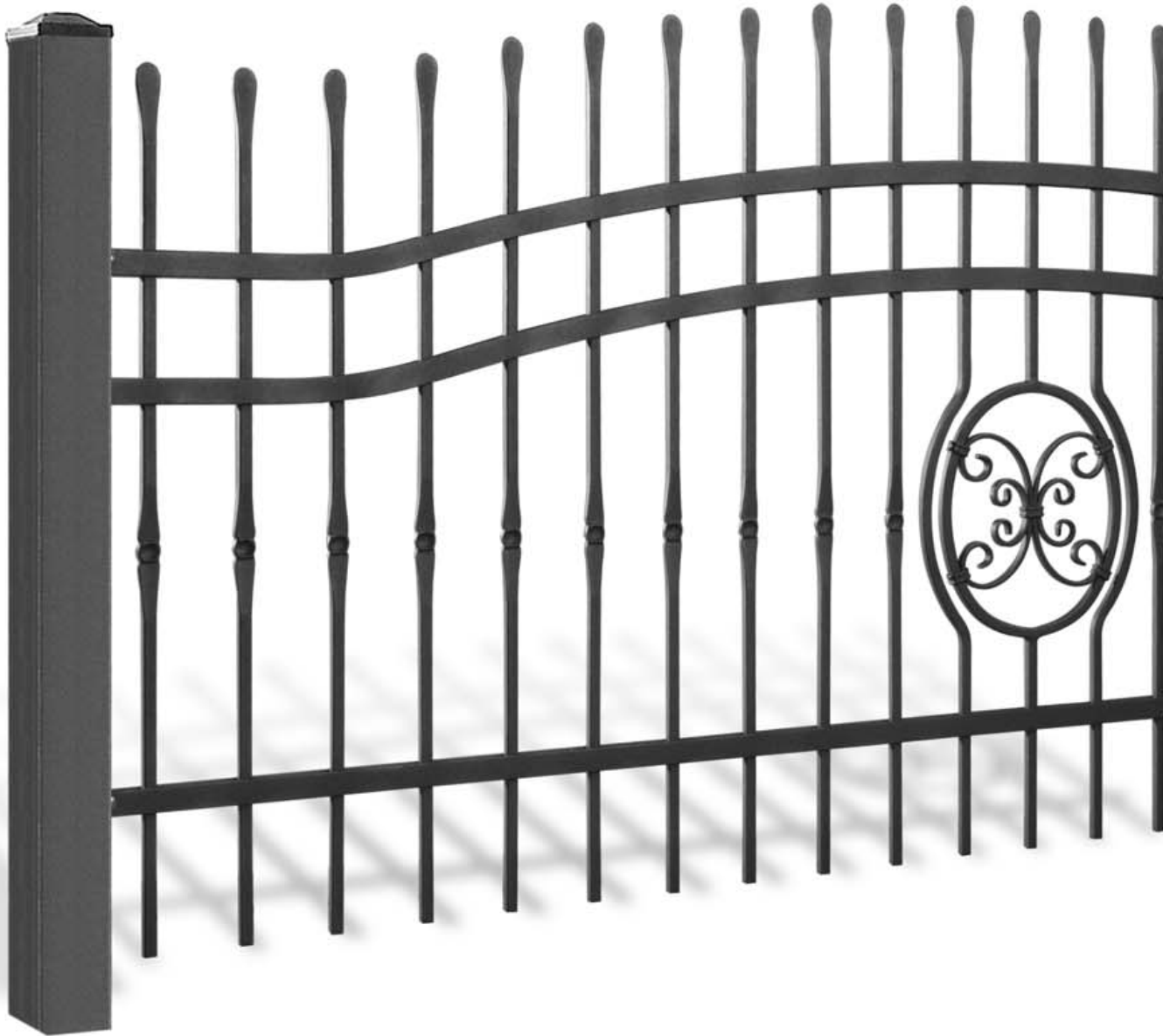

System Łux
AW.10.59



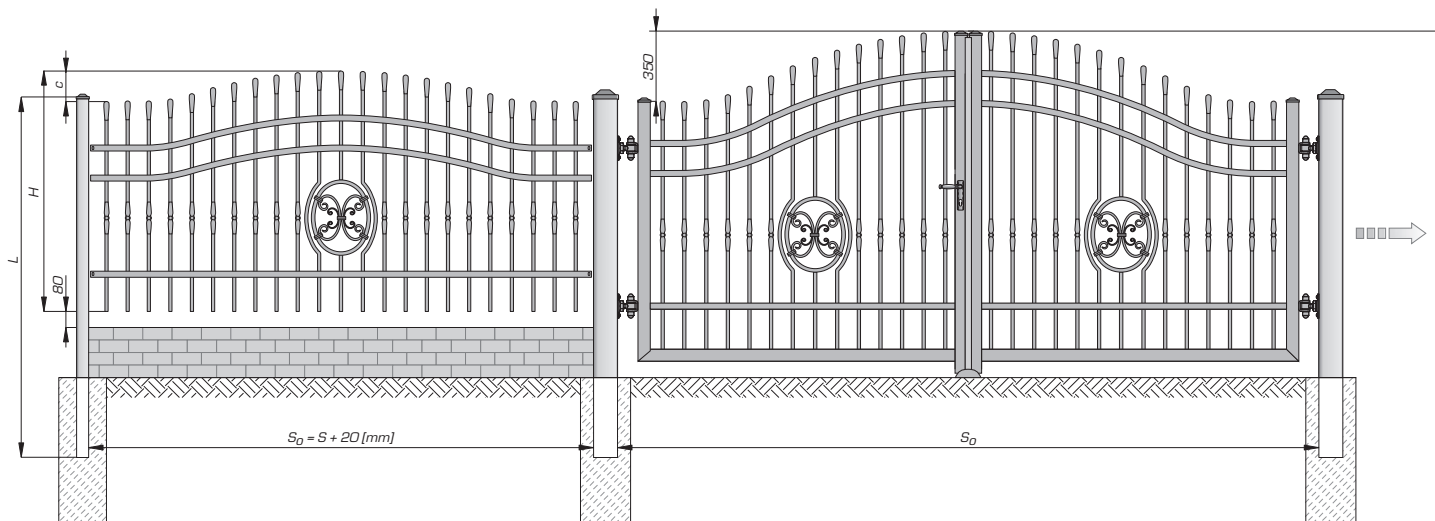
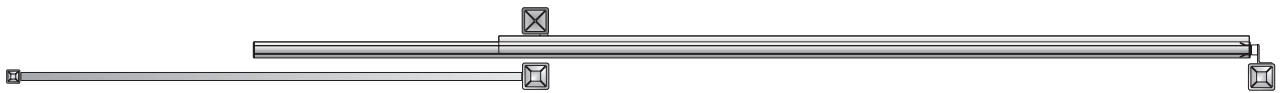
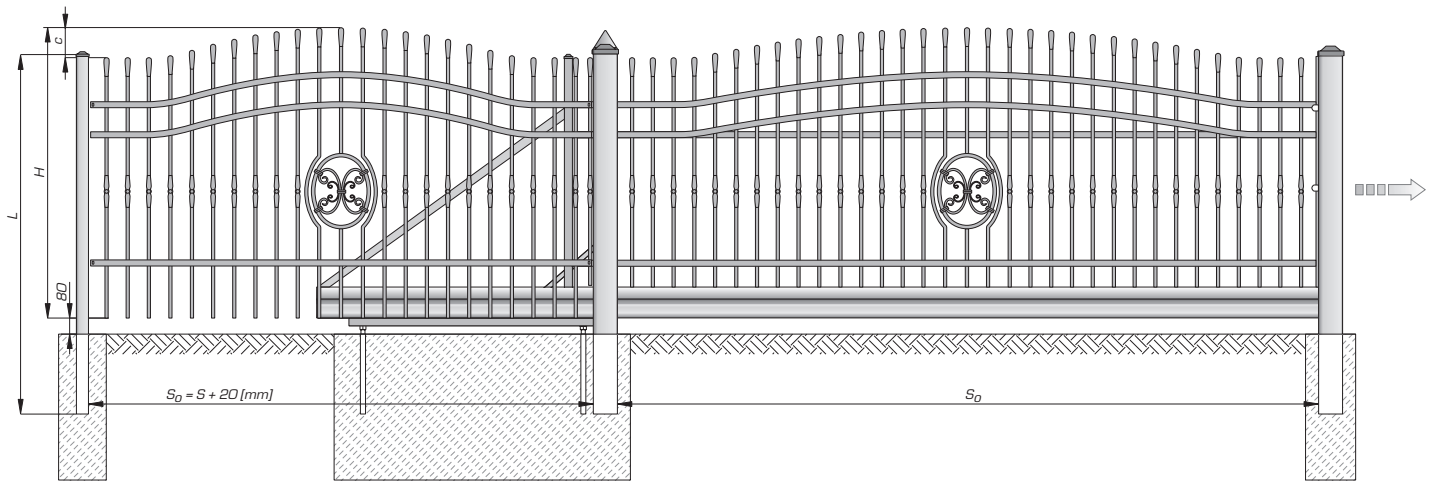

AW.10.59/Wp

(S) 2500 [mm] x (H) 1200 [mm] - 64 kg (S) 2500 [mm] x (H) 1450 [mm] - 75 kg
max: (S) 3000 [mm] x (H) 1750 [mm]

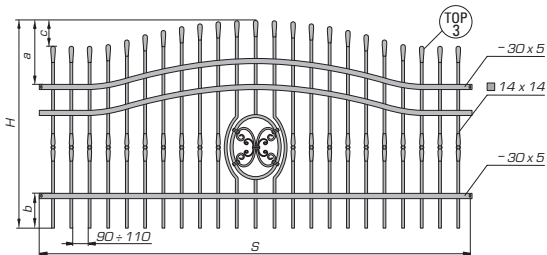

H=1450 : a=370, b=300, c=150, H_{min}=1150 H=1200 : a=370, b=100 ÷ 300, c=150, H_{min}=1150

AW.10.59/P

(S) 2500 [mm] x (H) 1200 [mm] - 67 kg (S) 2500 [mm] x (H) 1450 [mm] - 78 kg
max: (S) 3000 [mm] x (H) 1750 [mm]

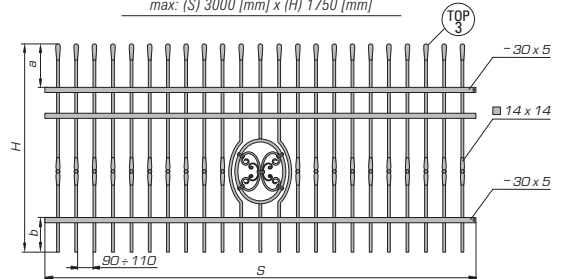

H=1450 : a=220, b=300, H_{min}=1000 H=1200 : a=220, b=100 ÷ 300, H_{min}=1000

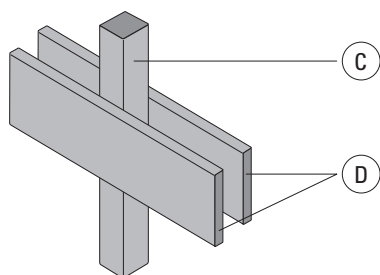
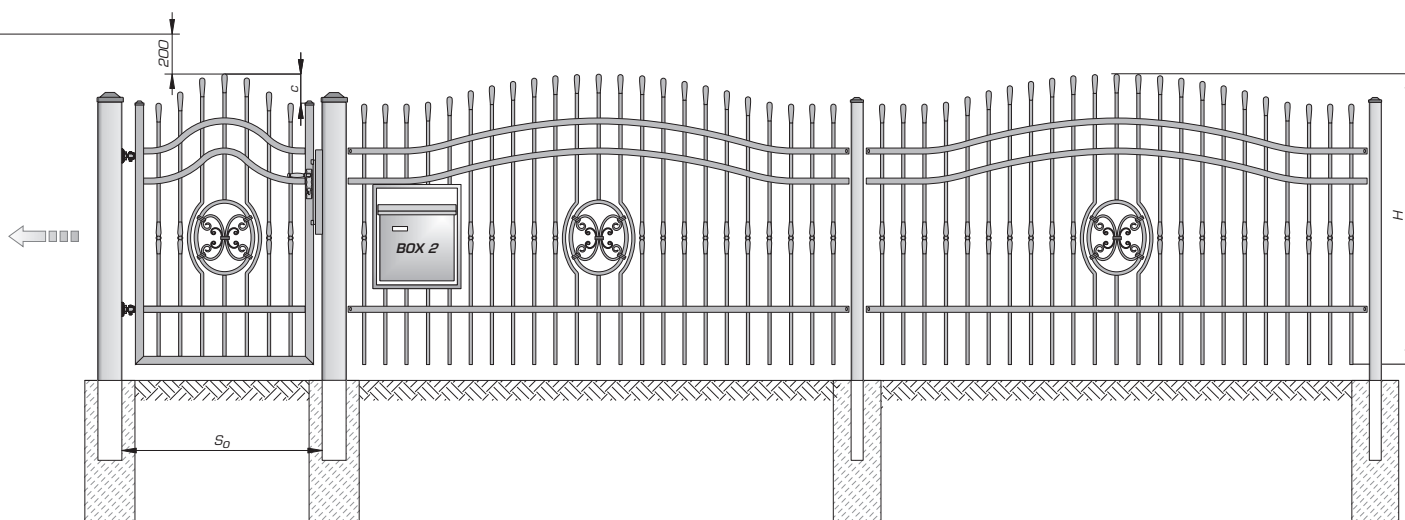
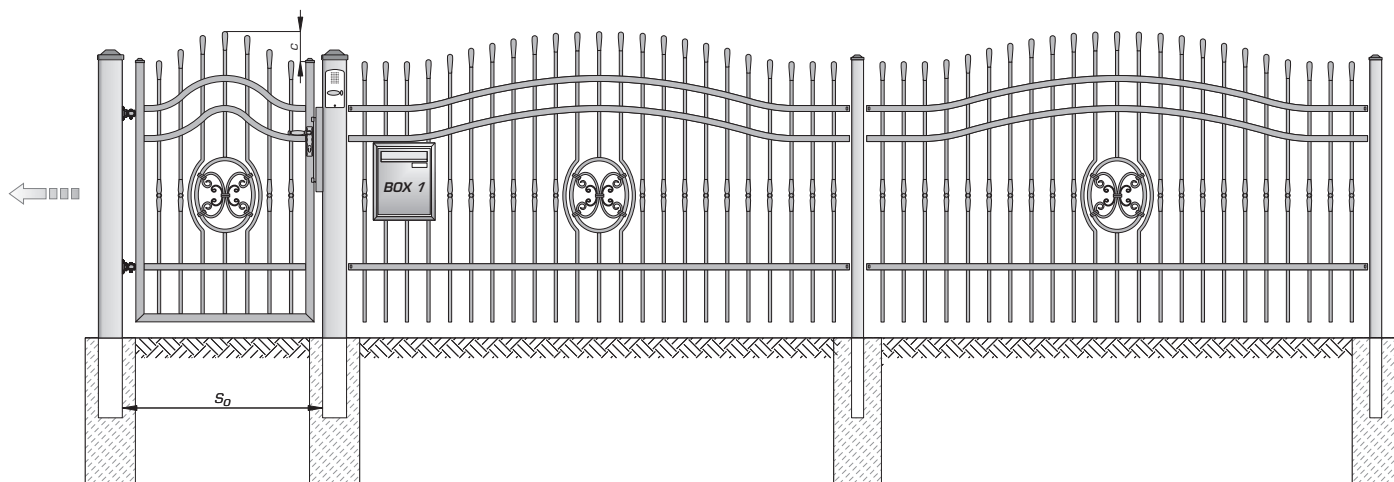

U3 C 14 x 14 D 30 x 5



System **Lox**
AW.10.60

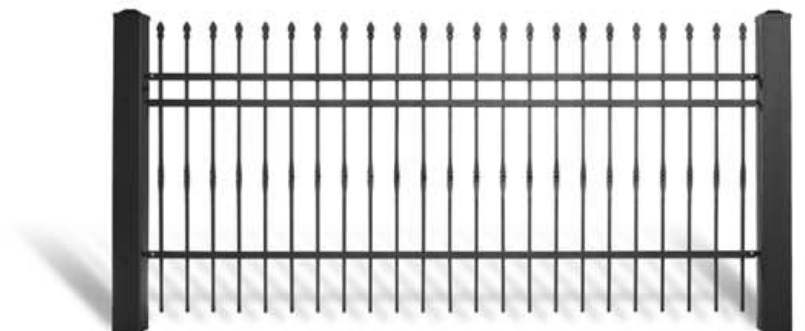
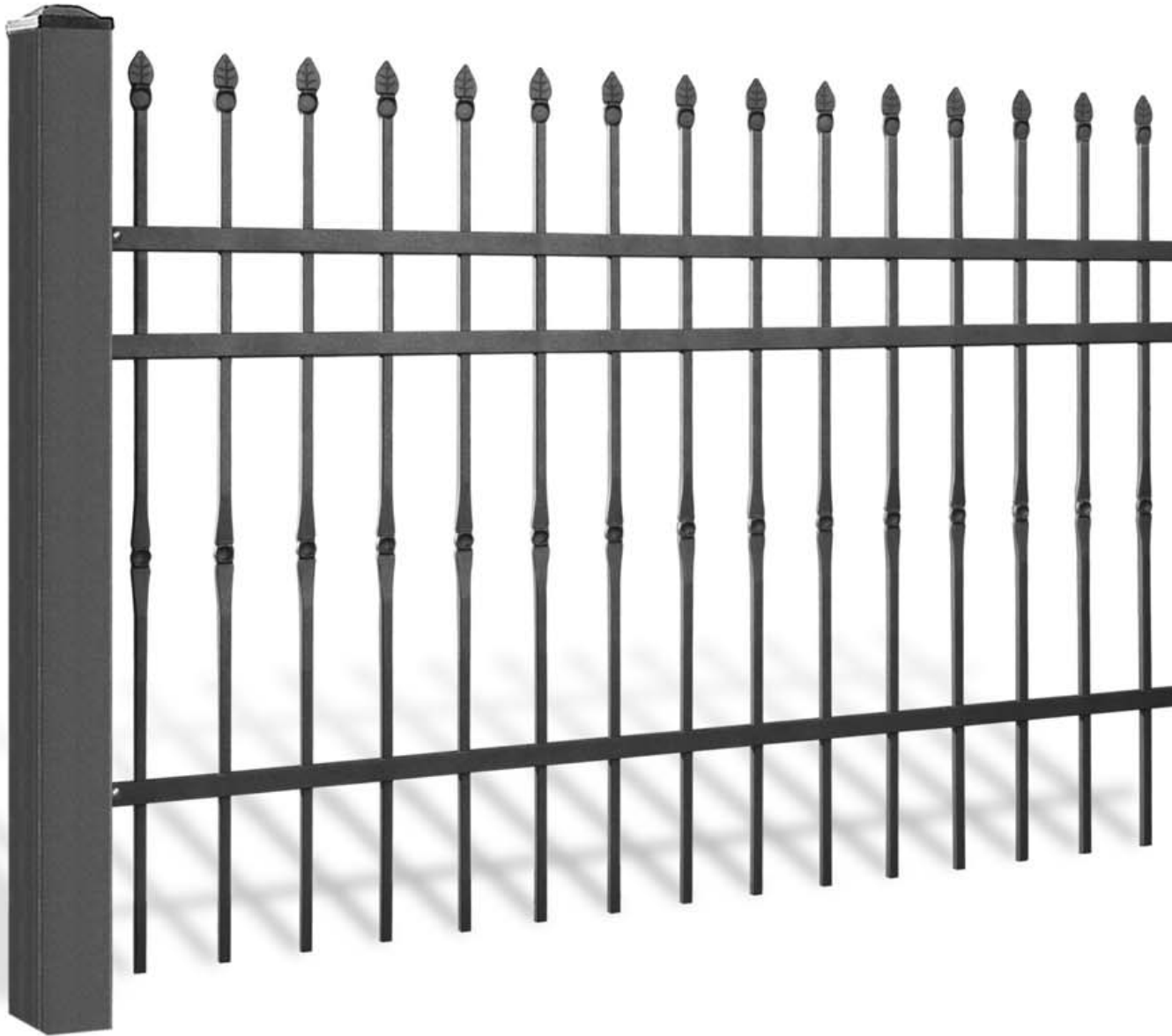

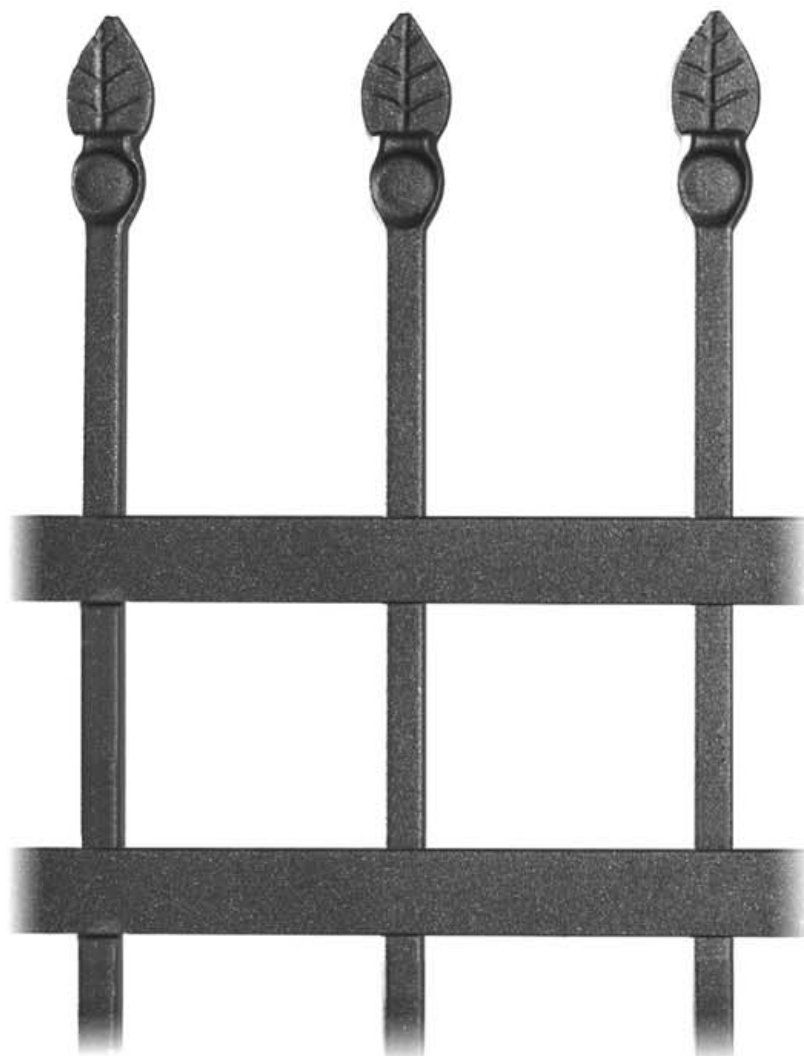

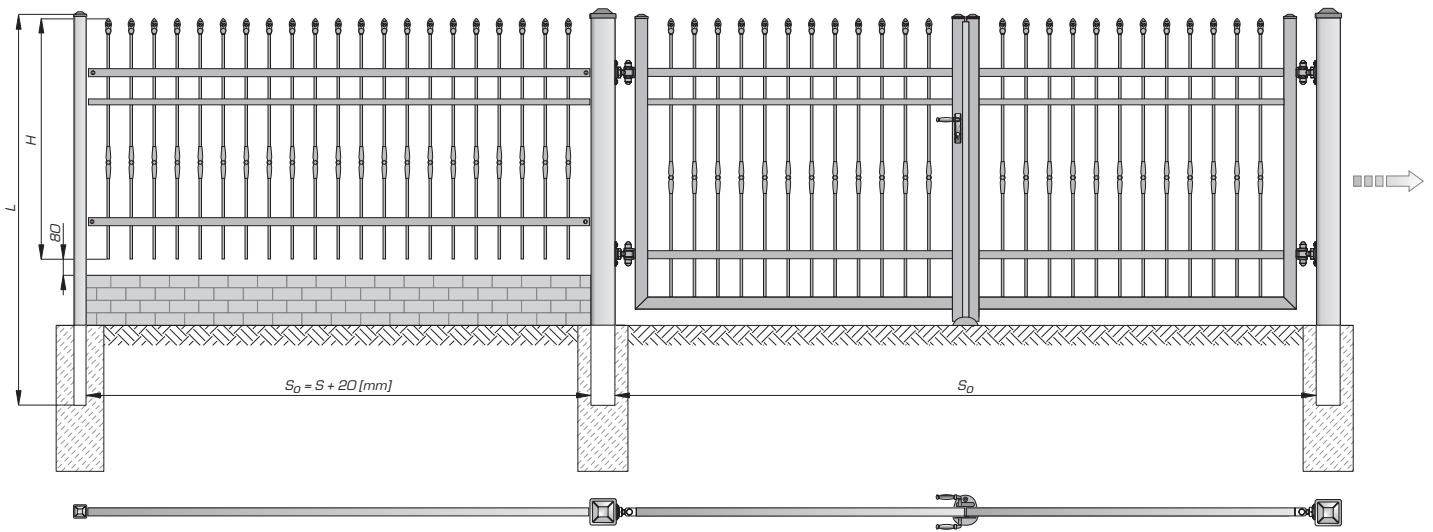
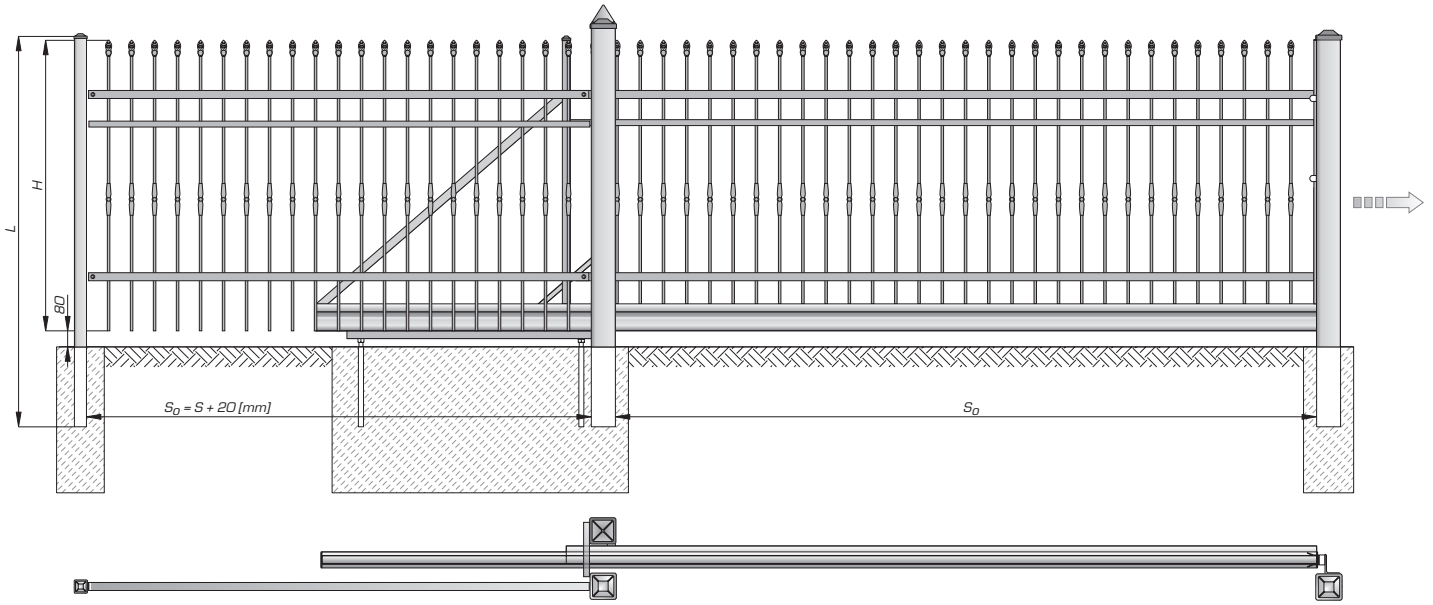

AW.10.60/P

- (S) 2500 [mm] x (H) 900 [mm] - 60 kg
- (S) 2500 [mm] x (H) 1200 [mm] - 65 kg
- (S) 2500 [mm] x (H) 1450 [mm] - 70 kg
- max: (S) 3000 [mm] x (H) 1750 [mm]

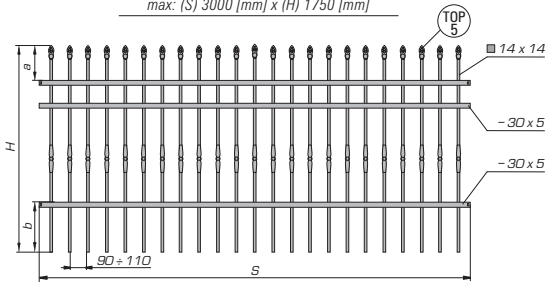

H = 1450 : a=250, b=300, H_{min}=800 H = 1200 : a=250, b=100 ± 300, H_{min}=800

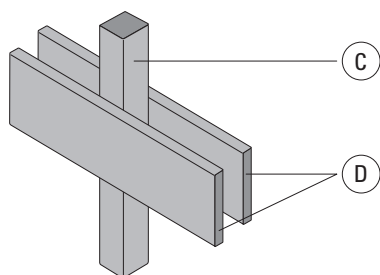
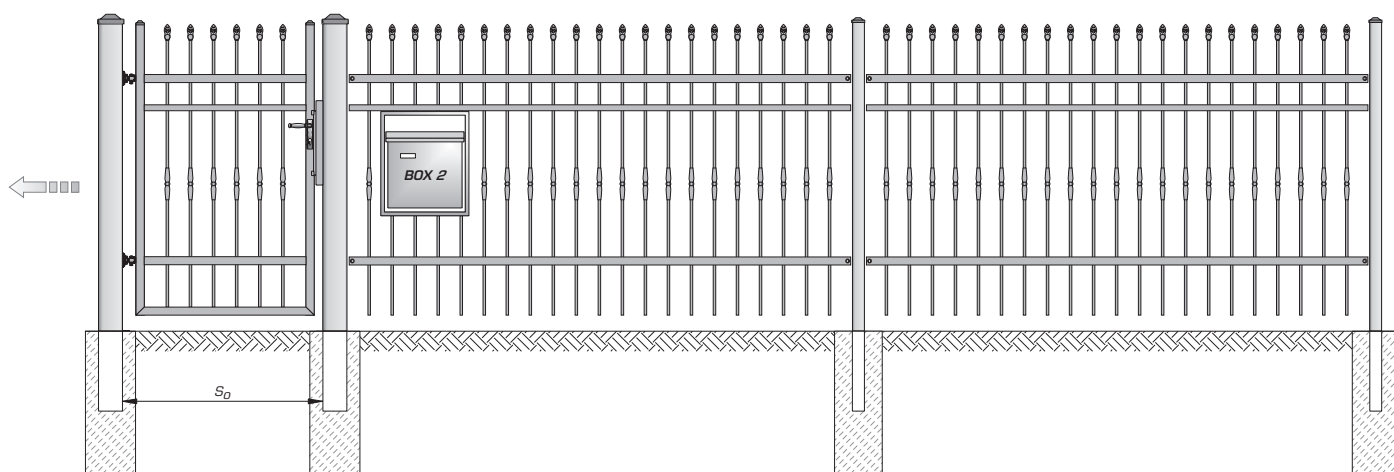
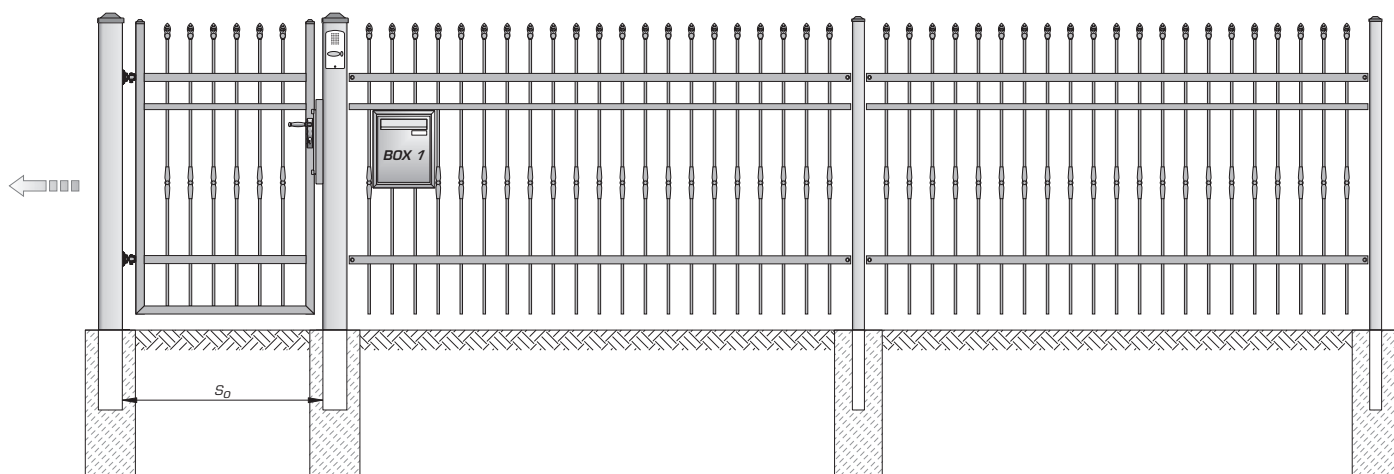

U3 C 14 x 14 D 30 x 5



System Łux
AW.10.61

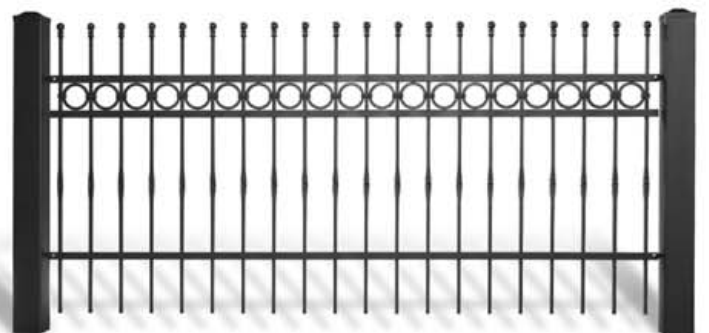
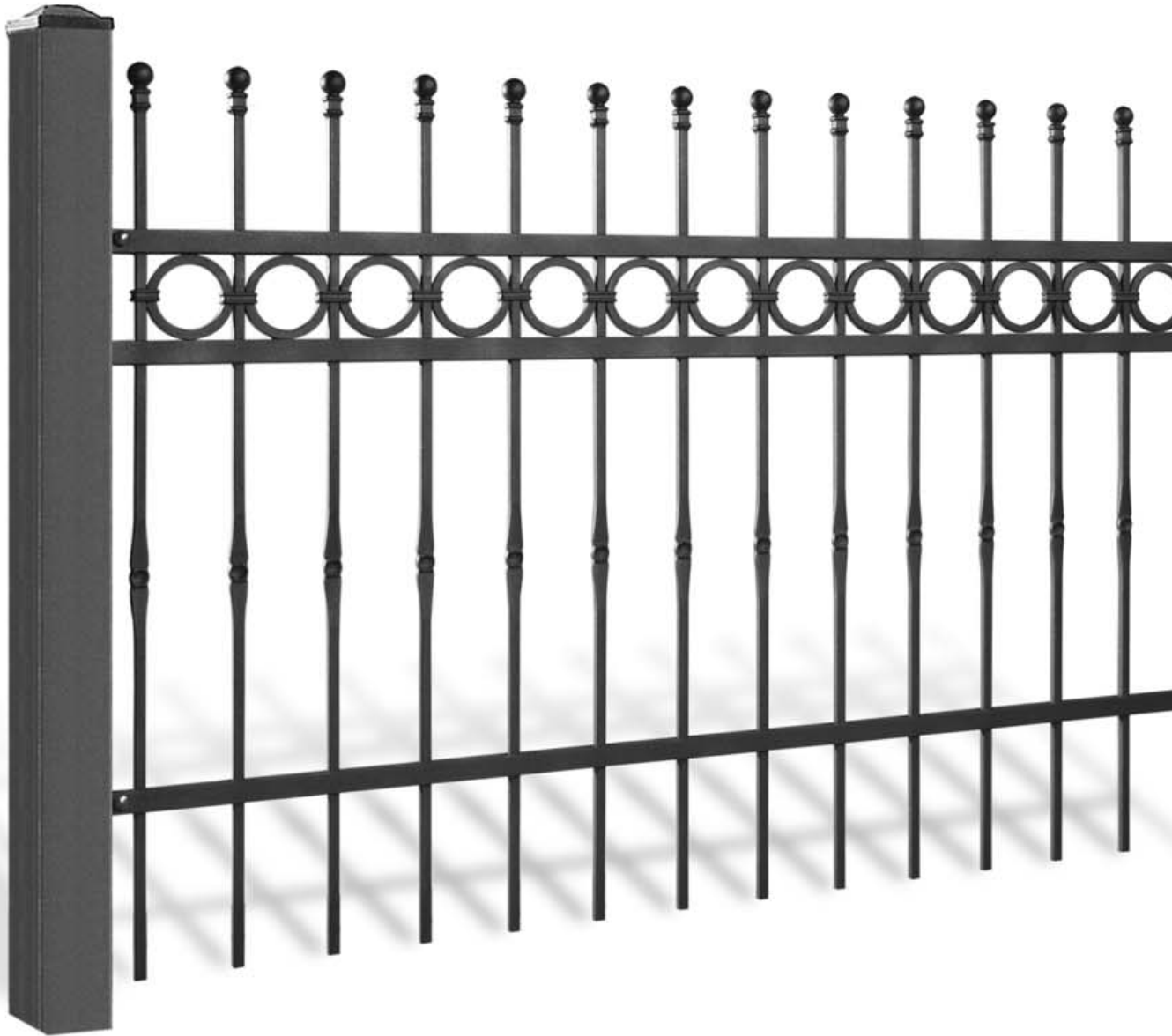

System ŁuX
AW.10.61

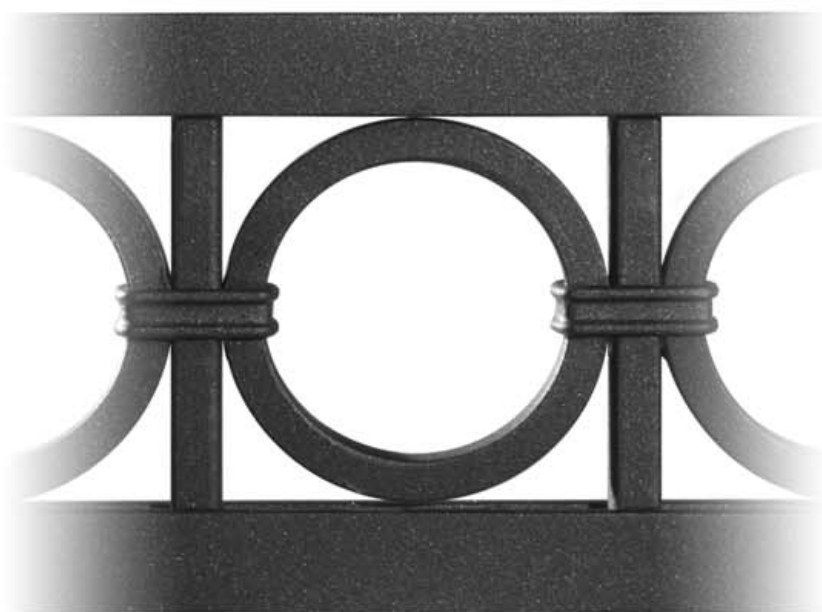

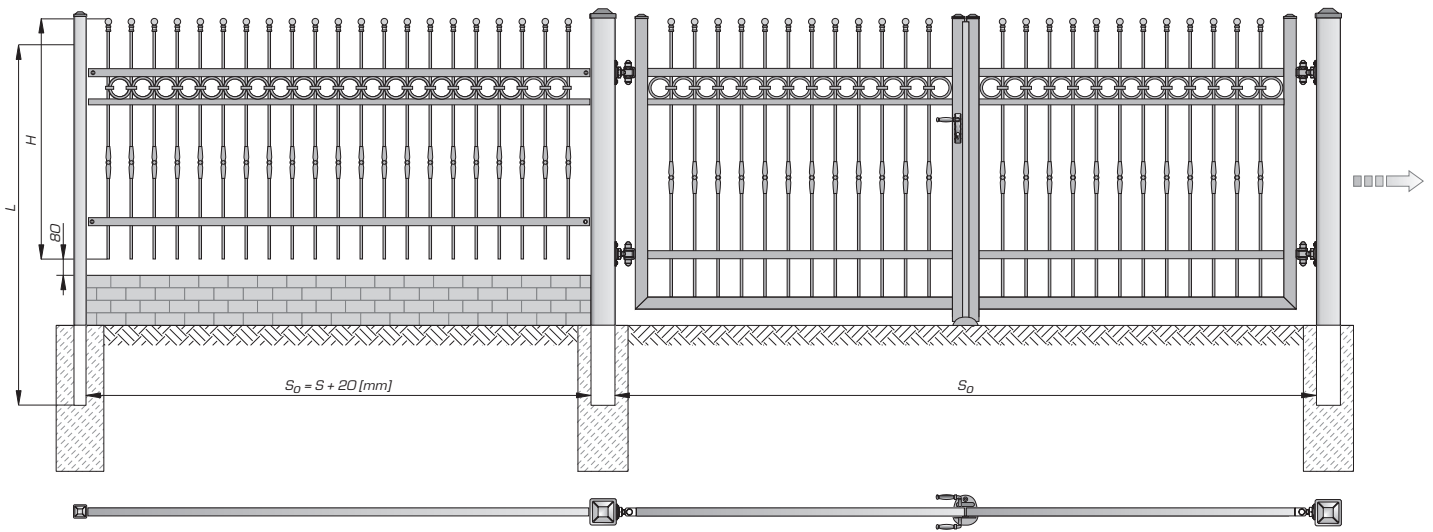
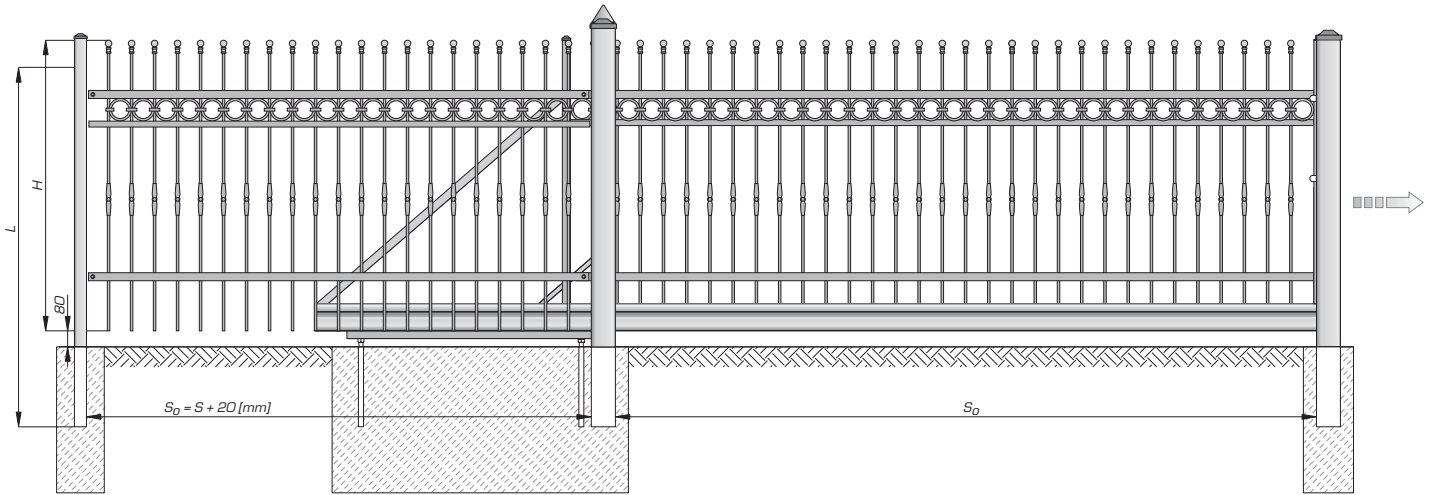

AW.10.61/P

(S) 2500 [mm] x (H) 900 [mm] - 56 kg
 (S) 2500 [mm] x (H) 1200 [mm] - 66 kg
 max: (S) 3000 [mm] x (H) 1750 [mm]

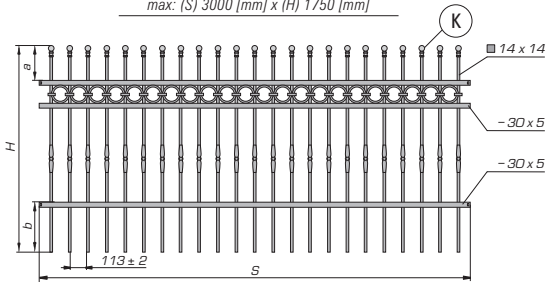

H = 1450 : a=220, b=300, H_{min}=800 H = 1200 : a=220, b=100 ÷ 300, H_{min}=800

AW.10.61/Wp

(S) 2500 [mm] x (H) 1200 [mm] - 63 kg
 (S) 2500 [mm] x (H) 1450 [mm] - 73 kg
 max: (S) 3000 [mm] x (H) 1750 [mm]

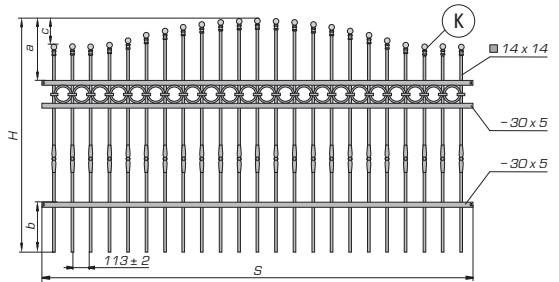

H = 1450 : a=370, b=300, c=150, H_{min}=1000 H = 1200 : a=370, b=100 ÷ 300, c=150, H_{min}=1000

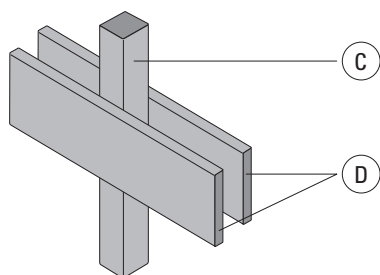
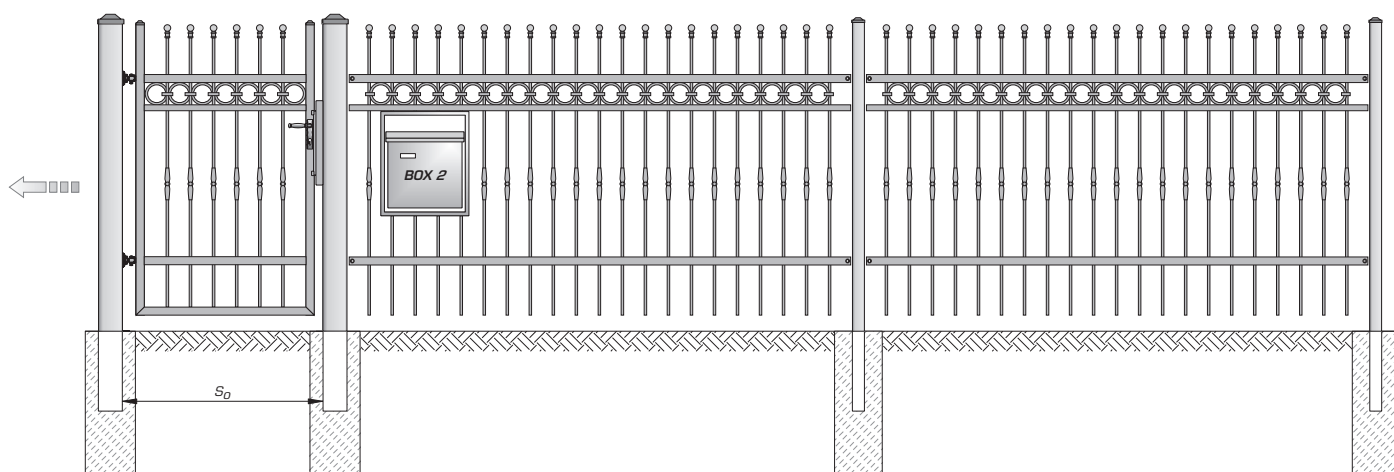
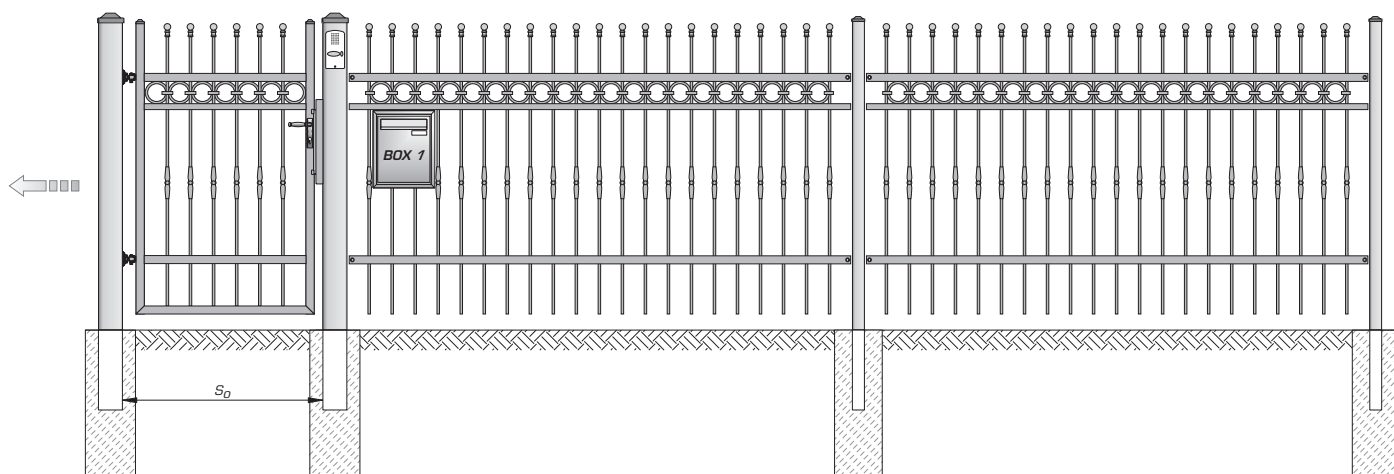

U3 C 14 x 14 D 30 x 5



System Lux
AW.10.62

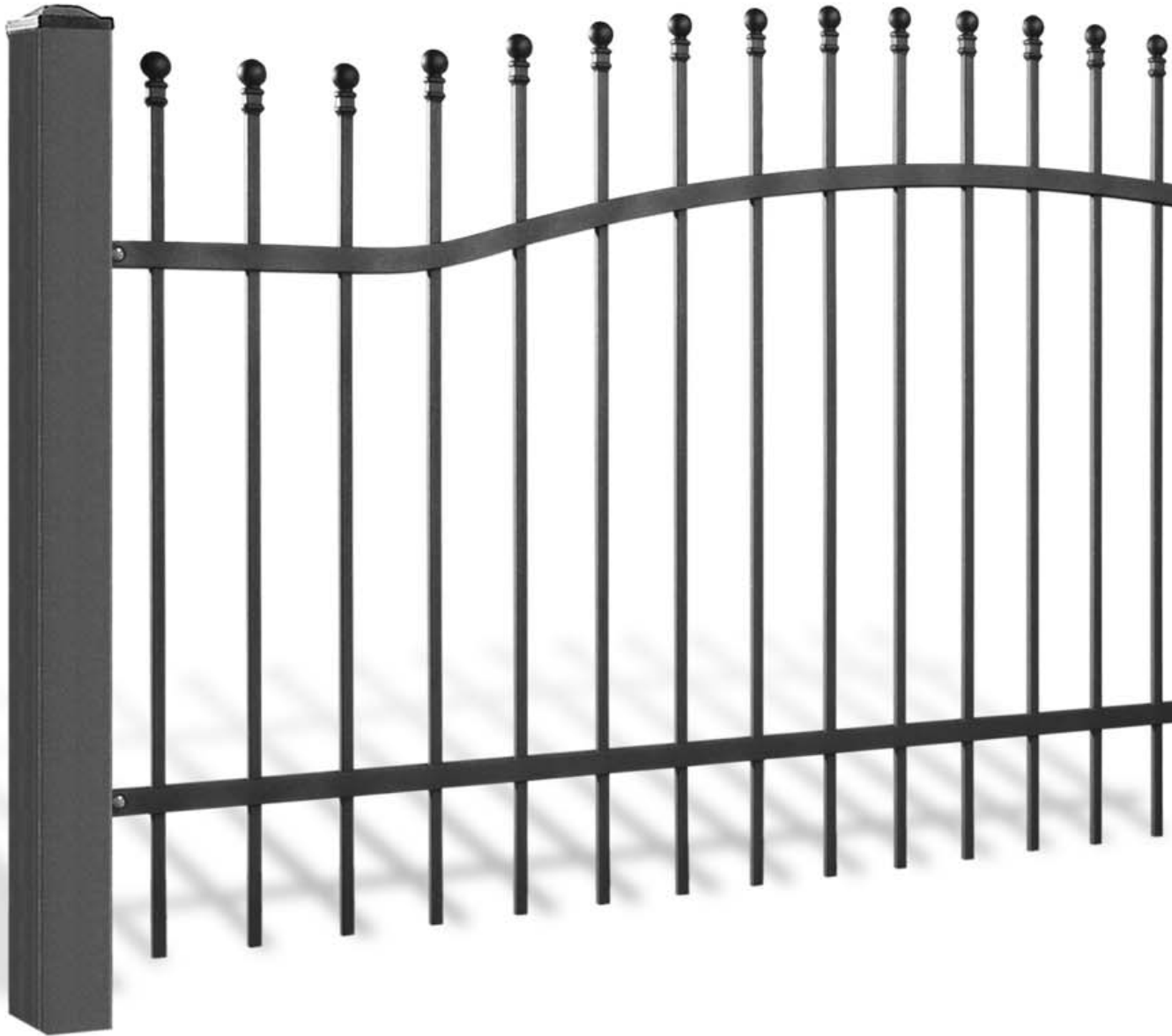



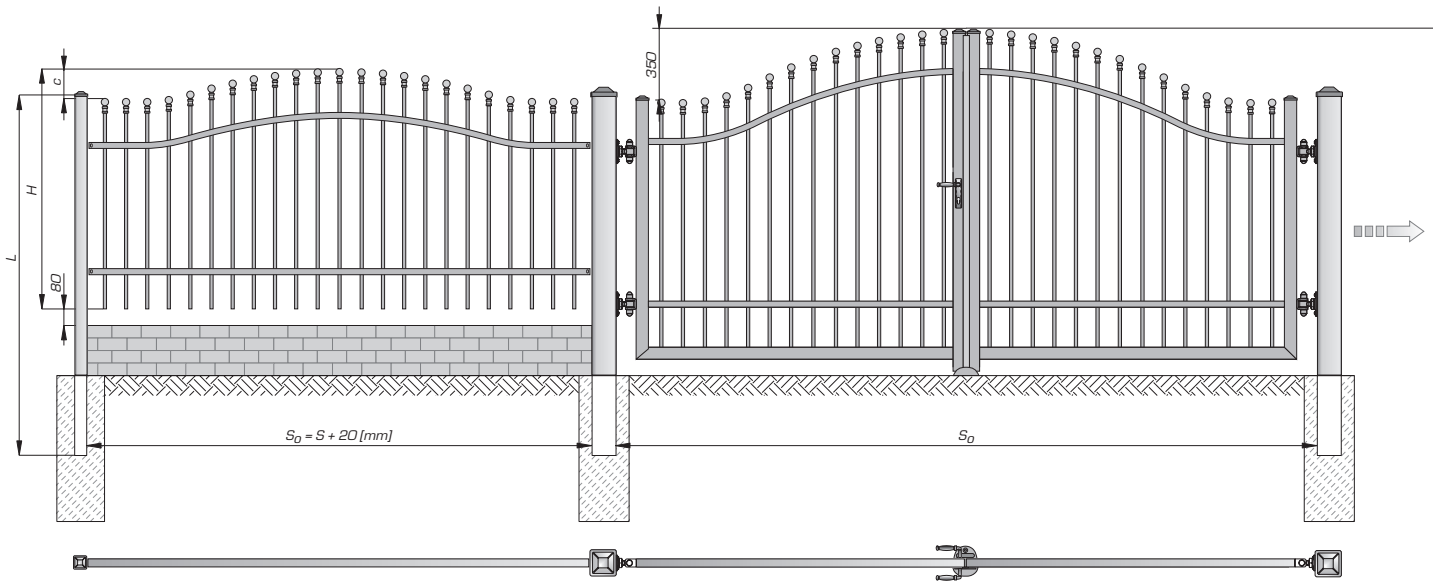
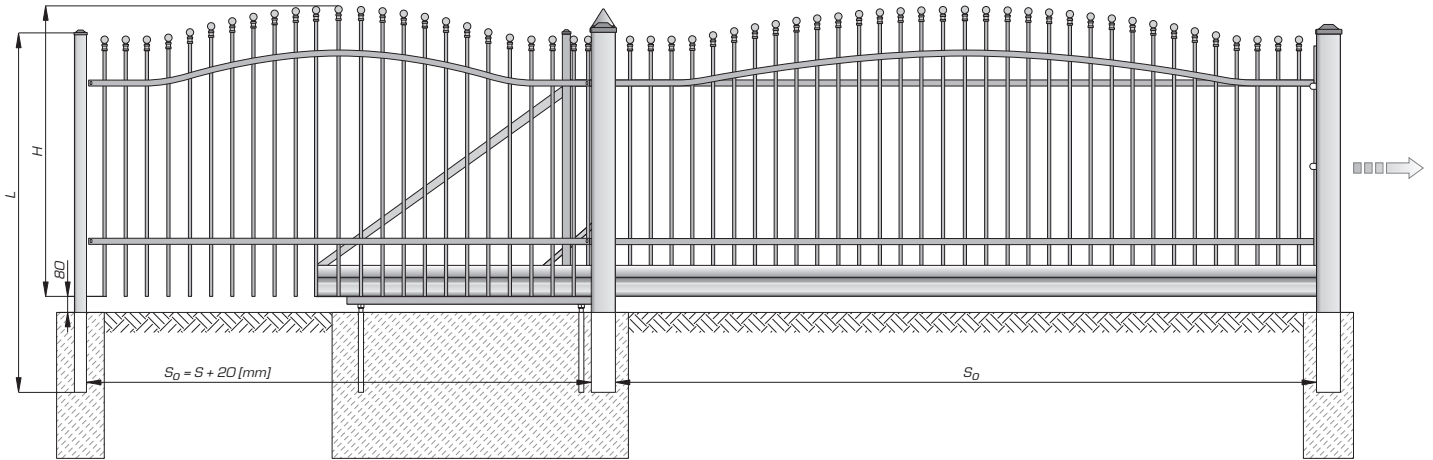

AW.10.62/Wp

(S) 2500 [mm] x (H) 1200 [mm] - 61 kg (S) 2500 [mm] x (H) 1450 [mm] - 71 kg
 max: (S) 3000 [mm] x (H) 1750 [mm]

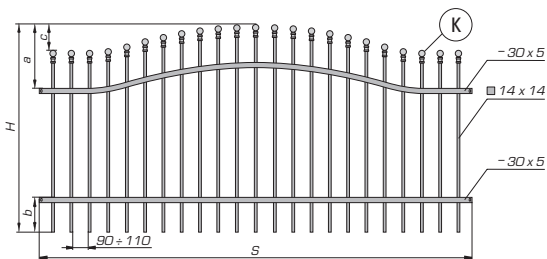

H=1450 : a=370, b=300, c=150, H_{min}=1150 H=1200 : a=370, b=100÷300, c=150, H_{min}=1150

AW.10.62/P

(S) 2500 [mm] x (H) 1200 [mm] - 64 kg (S) 2500 [mm] x (H) 1450 [mm] - 74 kg
 max: (S) 3000 [mm] x (H) 1750 [mm]

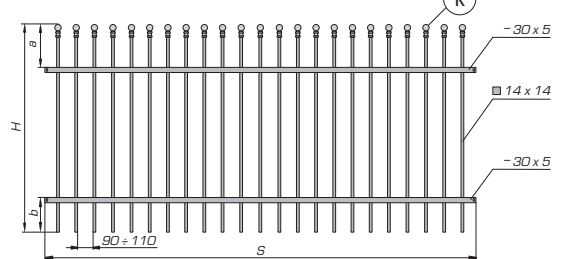

H=1450 : a=220, b=300, H_{min}=1000 H=1200 : a=220, b=100÷300, H_{min}=1000

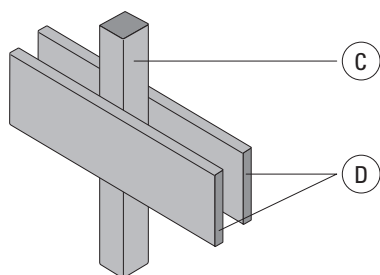
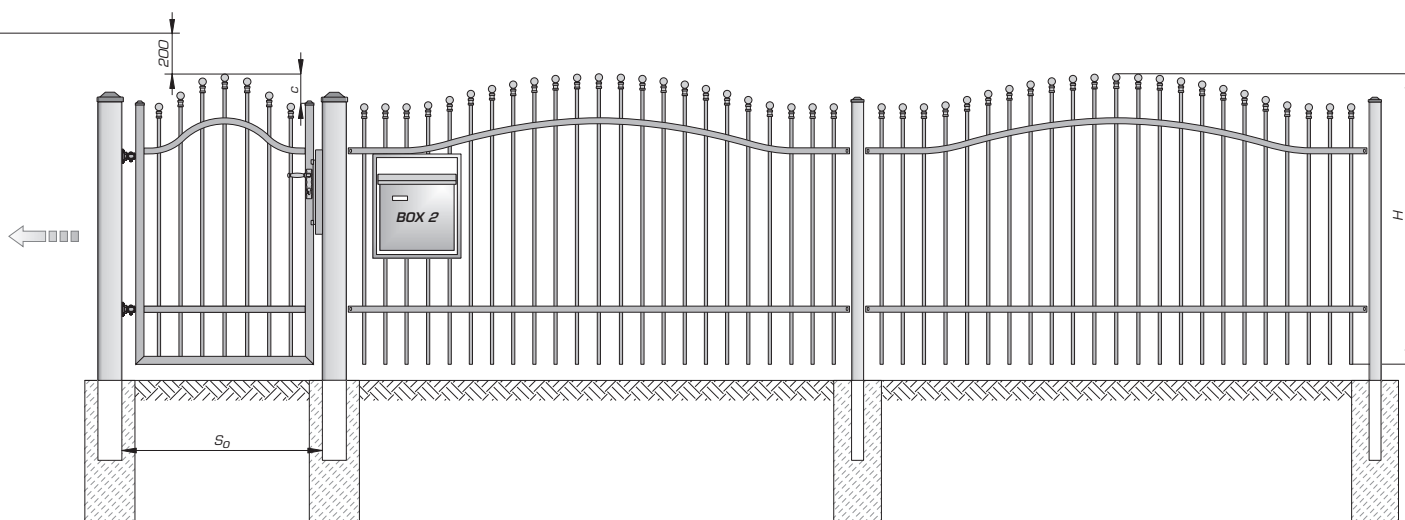
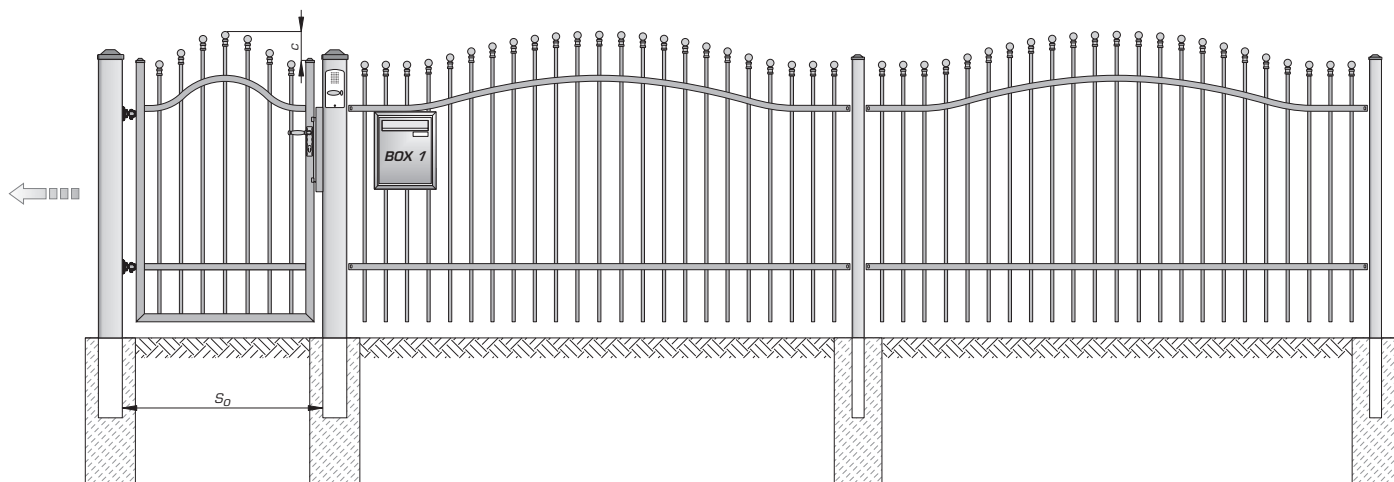

U3 C 14 x 14 D 30 x 5



System *Style*
AW.10.07

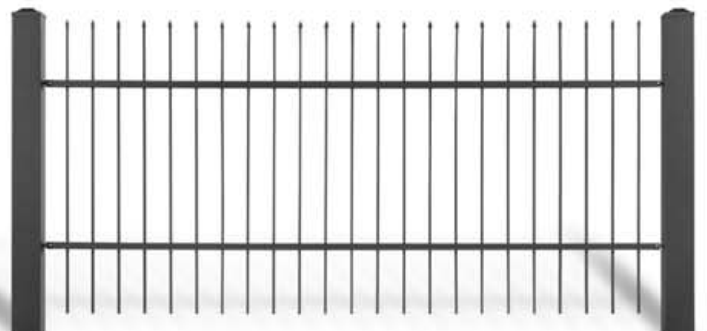



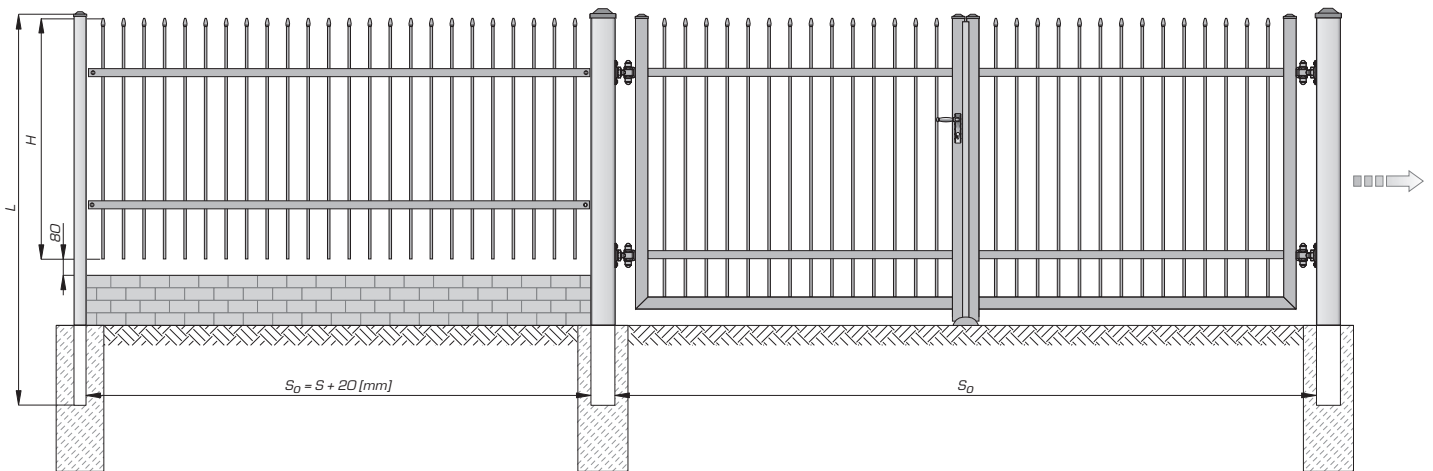
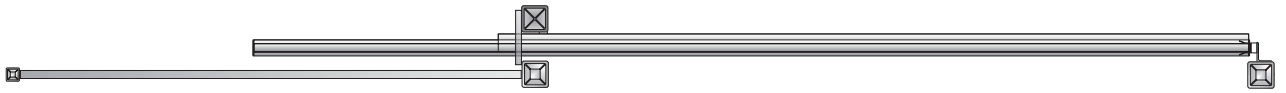
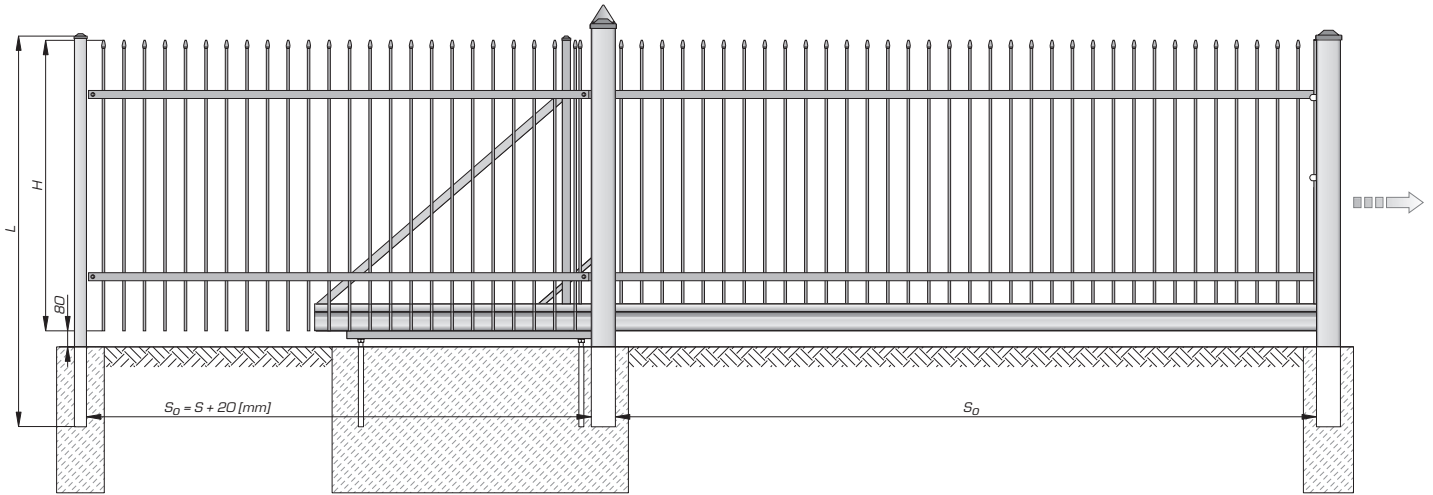

AW.10.07/P

(S) 2500 [mm] x (H) 900 [mm] - 37 kg	(S) 3000 [mm] x (H) 1200 [mm] - 55 kg
(S) 2500 [mm] x (H) 1200 [mm] - 45 kg	(S) 3000 [mm] x (H) 1450 [mm] - 64 kg
(S) 2500 [mm] x (H) 1450 [mm] - 53 kg	
max: (S) 3000 [mm] x (H) 1750 [mm]	

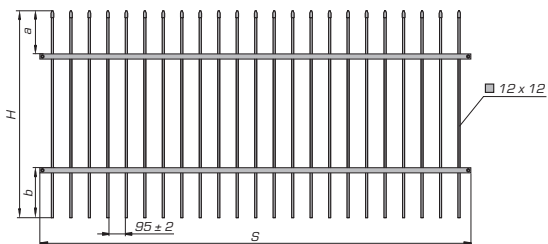

$H \geq 1000$: $a=250$, $b=300$, $H_{min}=800$ $800 \leq H < 1000$: $a=250$, $b=200$, $H_{min}=800$

AW.10.07/Wp

(S) 2500 [mm] x (H) 900 [mm] - 35 kg	(S) 3000 [mm] x (H) 1200 [mm] - 53 kg
(S) 2500 [mm] x (H) 1200 [mm] - 43 kg	(S) 3000 [mm] x (H) 1450 [mm] - 62 kg
(S) 2500 [mm] x (H) 1450 [mm] - 51 kg	
max: (S) 3000 [mm] x (H) 1750 [mm]	

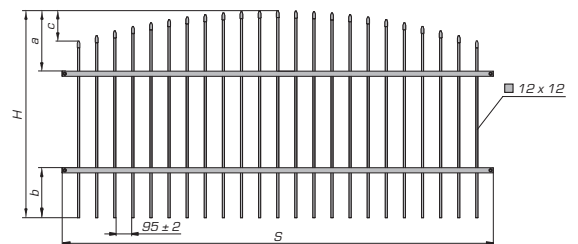

$H \geq 1100$: $a=350$, $b=300$, $c=175$, $H_{min}=900$ $900 \leq H < 1100$: $a=350$, $b=200$, $c=175$, $H_{min}=900$

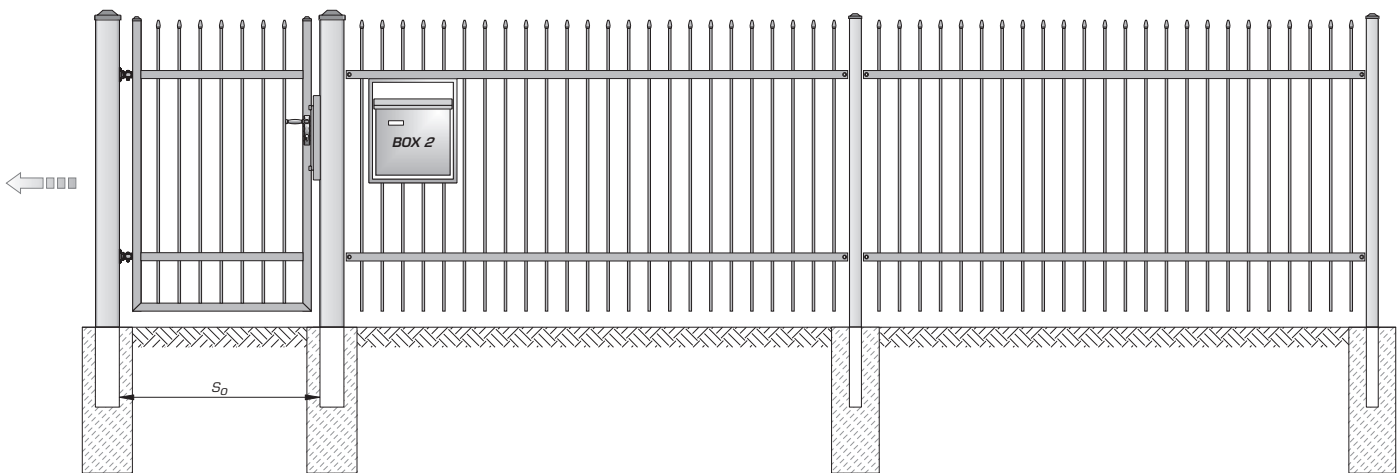
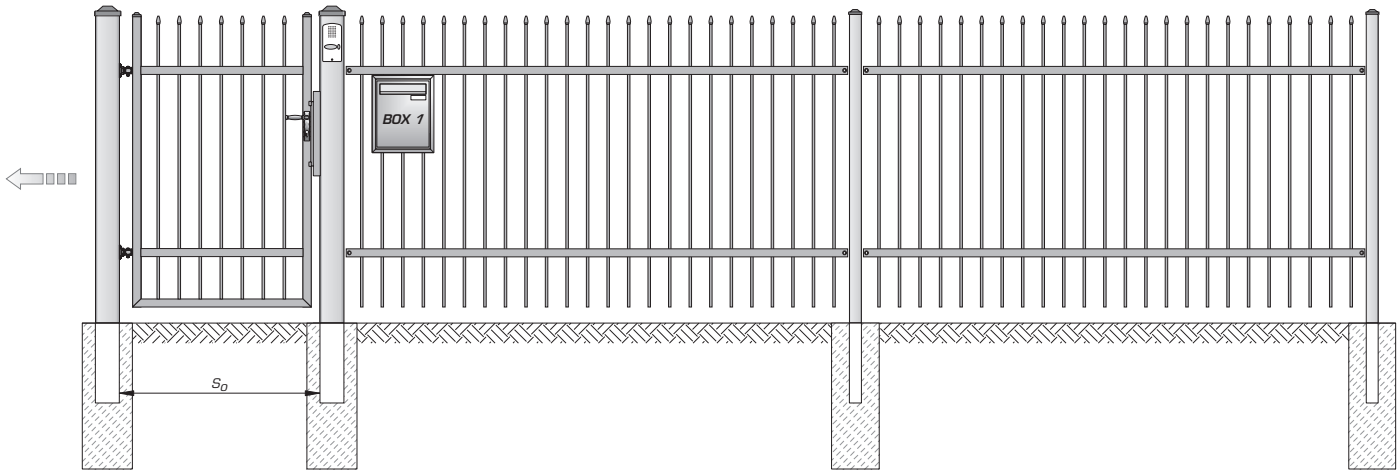

— AW.10.07/Wk —

(S) 2500 [mm] x (H) 900 [mm] - 35 kg	(S) 3000 [mm] x (H) 1200 [mm] - 53 kg
(S) 2500 [mm] x (H) 1200 [mm] - 43 kg	(S) 3000 [mm] x (H) 1450 [mm] - 62 kg
(S) 2500 [mm] x (H) 1450 [mm] - 51 kg	
max: (S) 3000 [mm] x (H) 1750 [mm]	

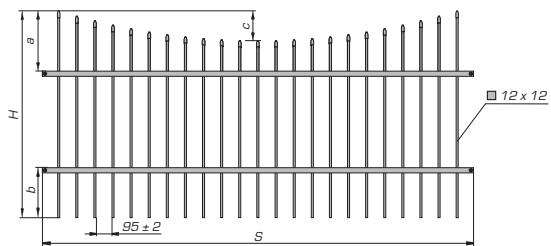

$H \geq 1100$: a=350, b=300, c=175, $H_{min}=900$ $900 \leq H < 1100$: a=350, b=200, c=175, $H_{min}=900$

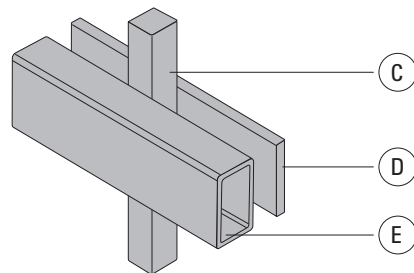

U2 C 12x12 D 30x5 E 30x18



System *Style*
AW.10.08

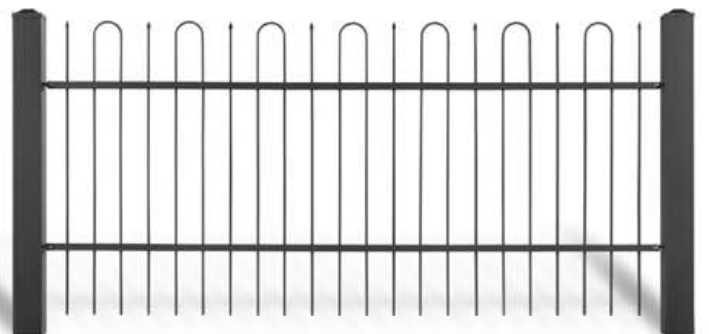
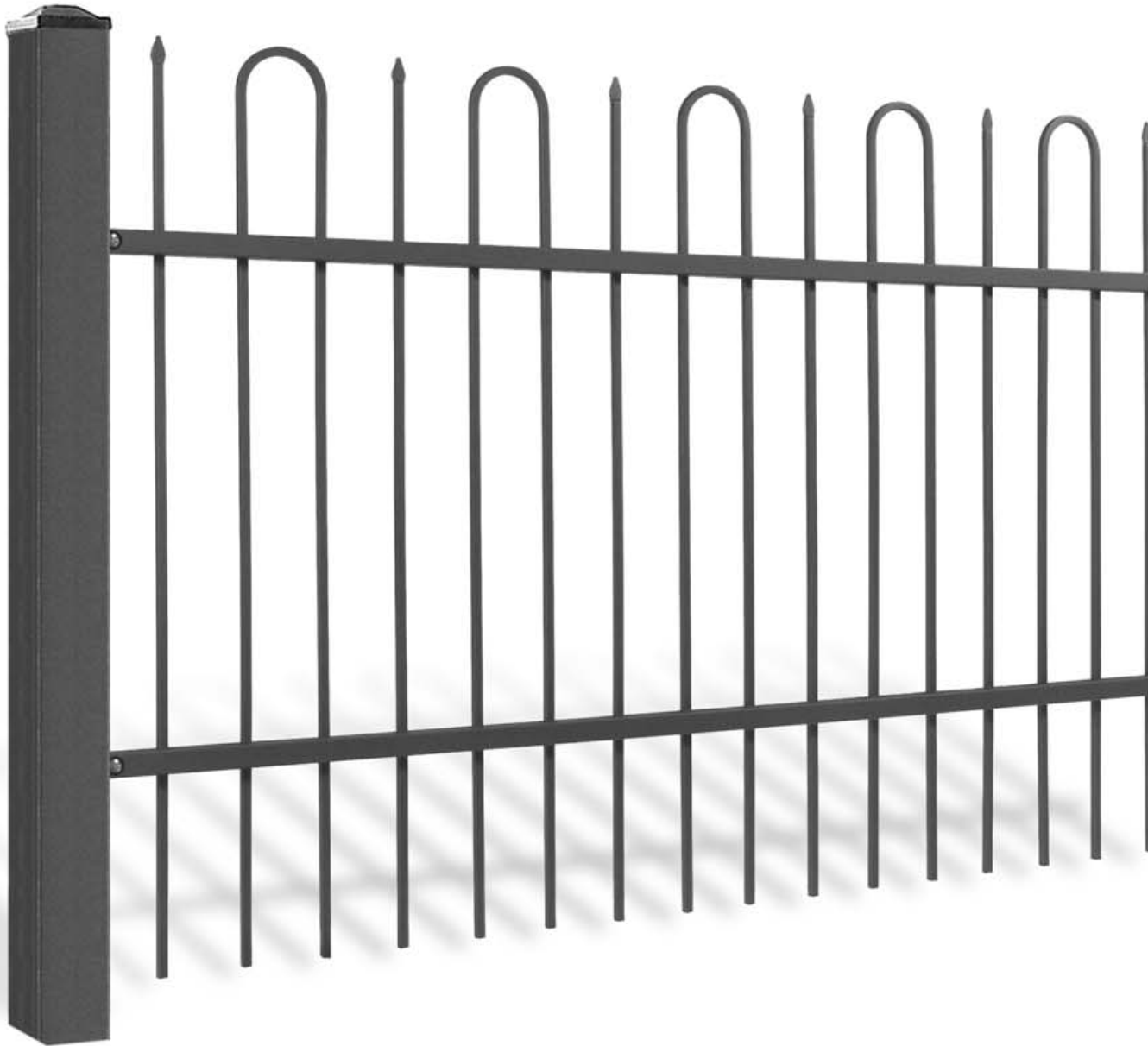

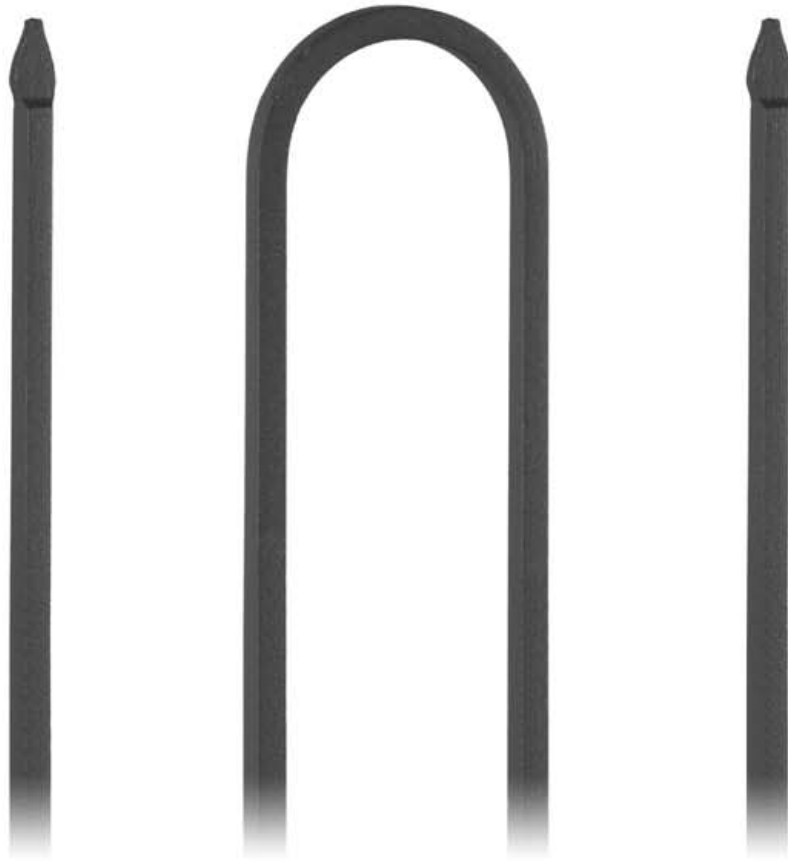

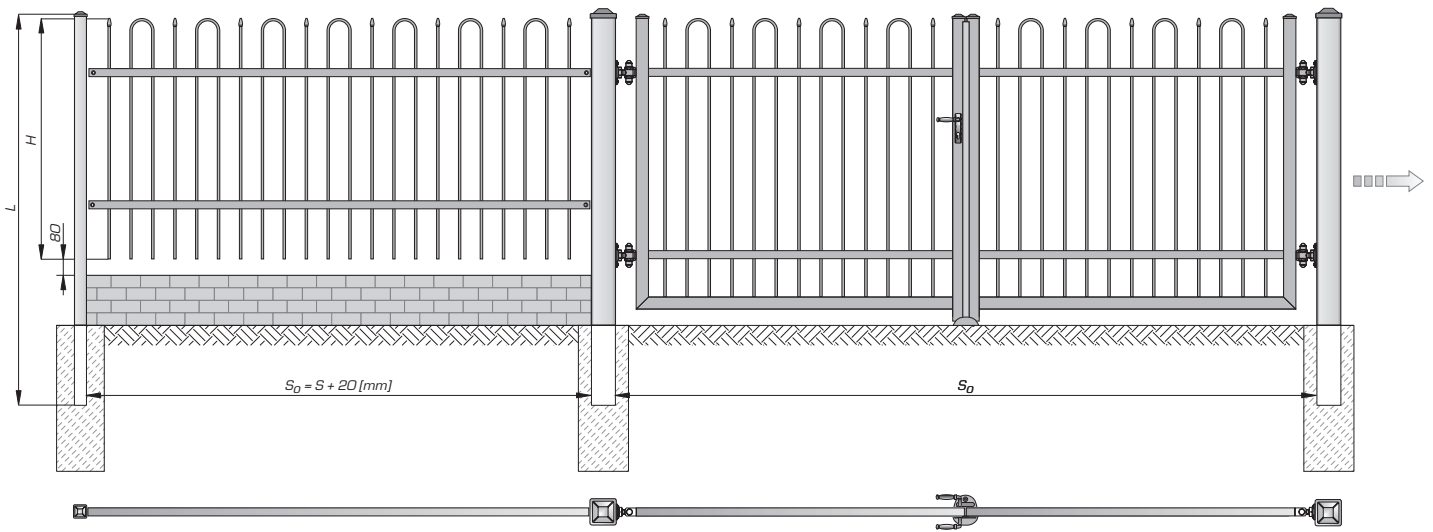
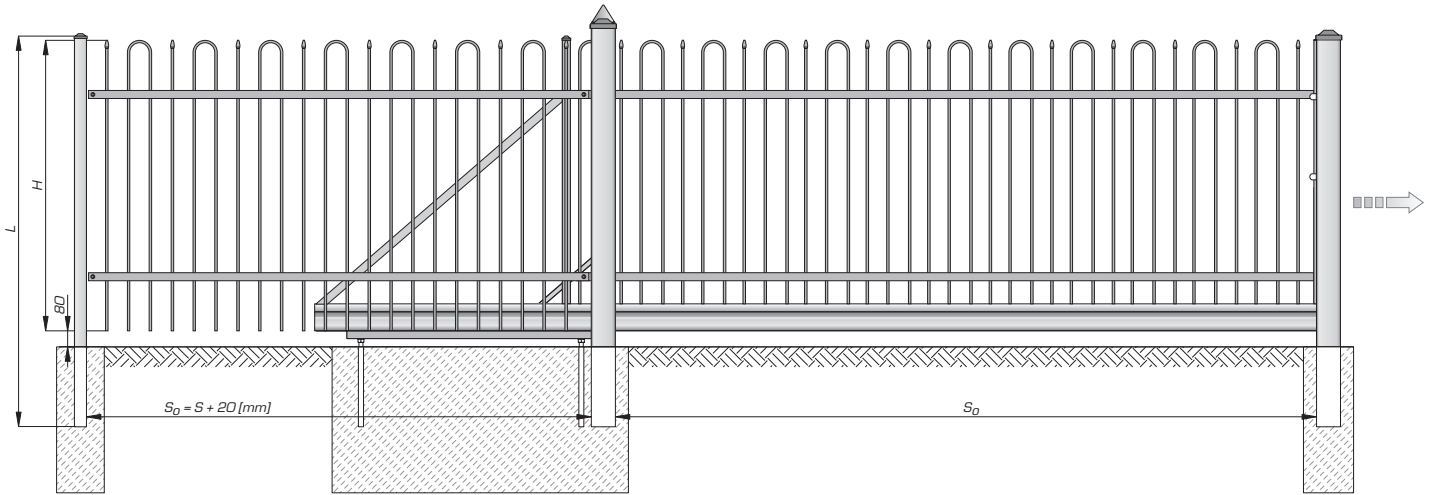

AW.10.08/P

(S) 2500 [mm] x (H) 900 [mm] - 41 kg	(S) 3000 [mm] x (H) 1200 [mm] - 55 kg
(S) 2500 [mm] x (H) 1200 [mm] - 48 kg	(S) 3000 [mm] x (H) 1450 [mm] - 64 kg
(S) 2500 [mm] x (H) 1450 [mm] - 55 kg	
max: (S) 3000 [mm] x (H) 1750 [mm]	

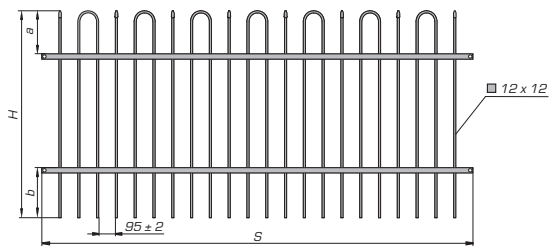

$H \geq 1000$: $a=250$, $b=300$, $H_{min}=800$ $800 \leq H < 1000$: $a=250$, $b=200$, $H_{min}=800$

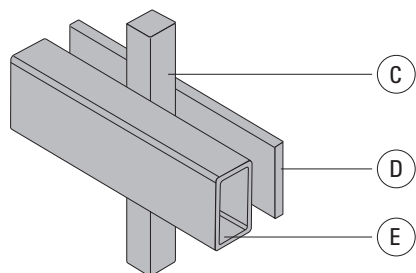
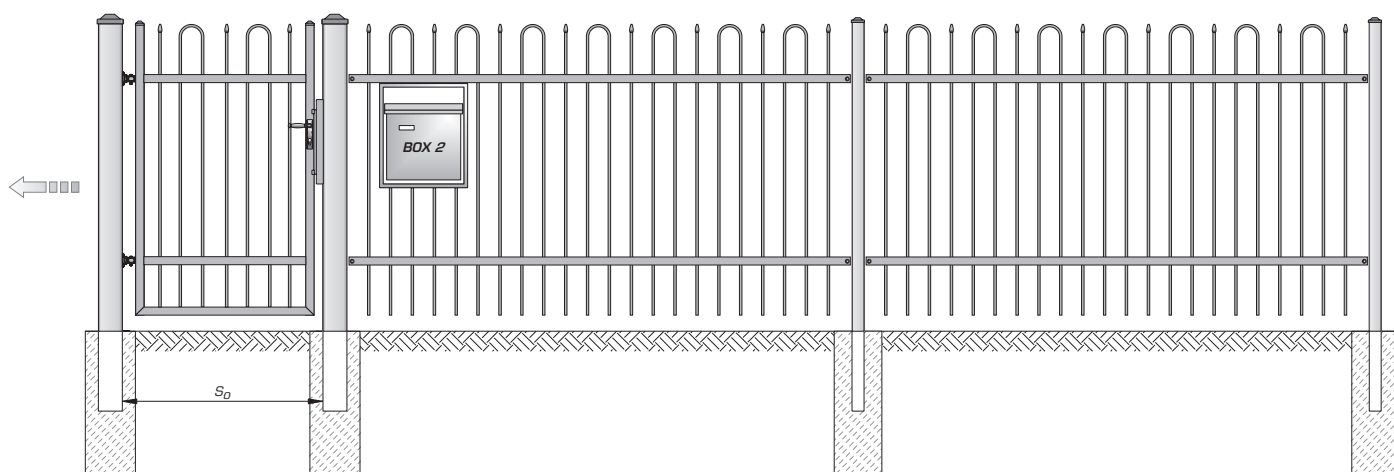
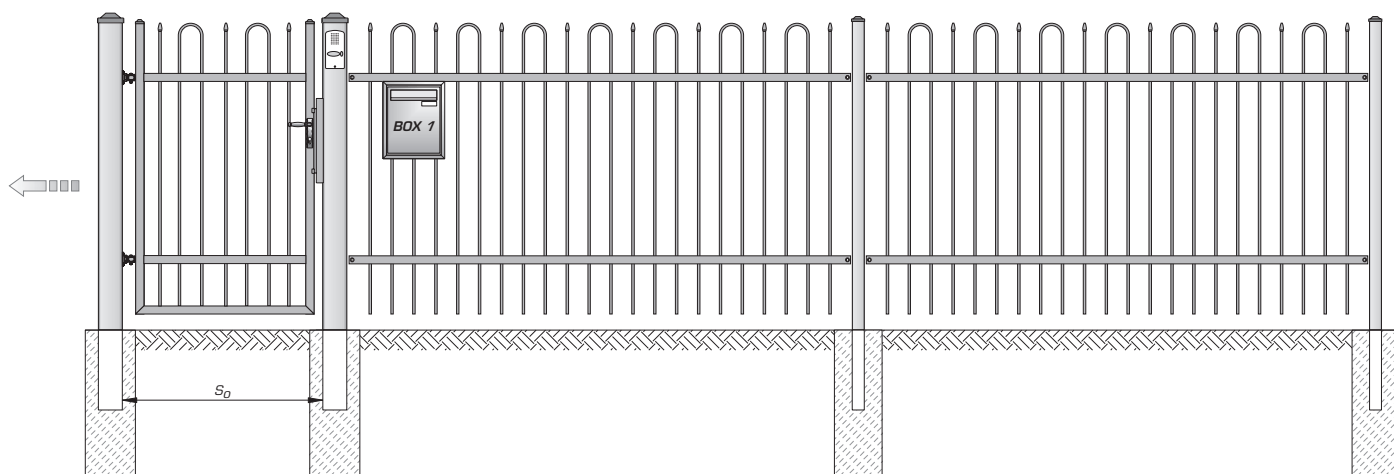

U2 **C** 12x12 **D** 30x5 **E** 30x18



System *Style*
AW.10.09

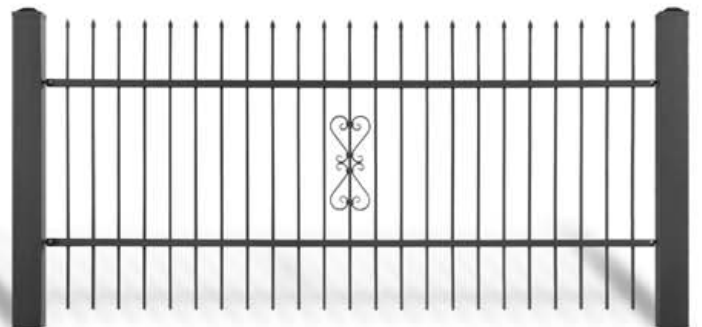

System *Style*
AW.10.09

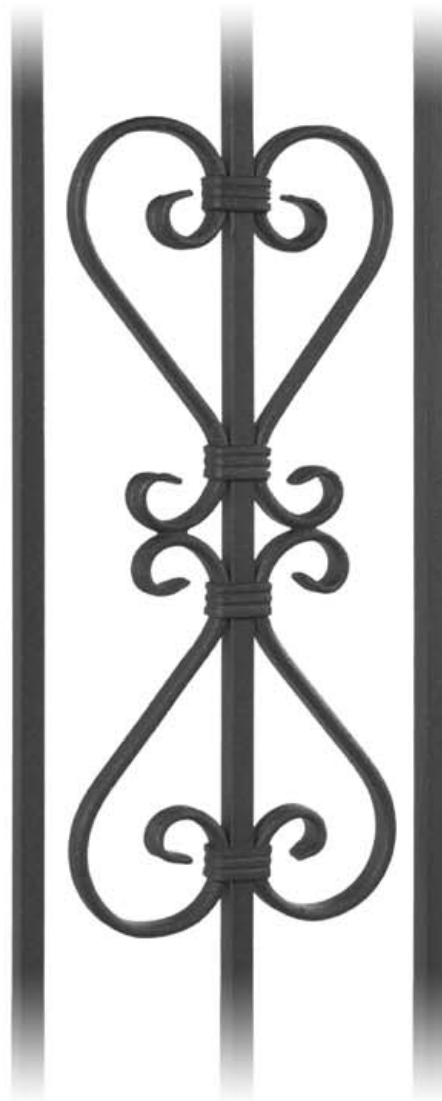

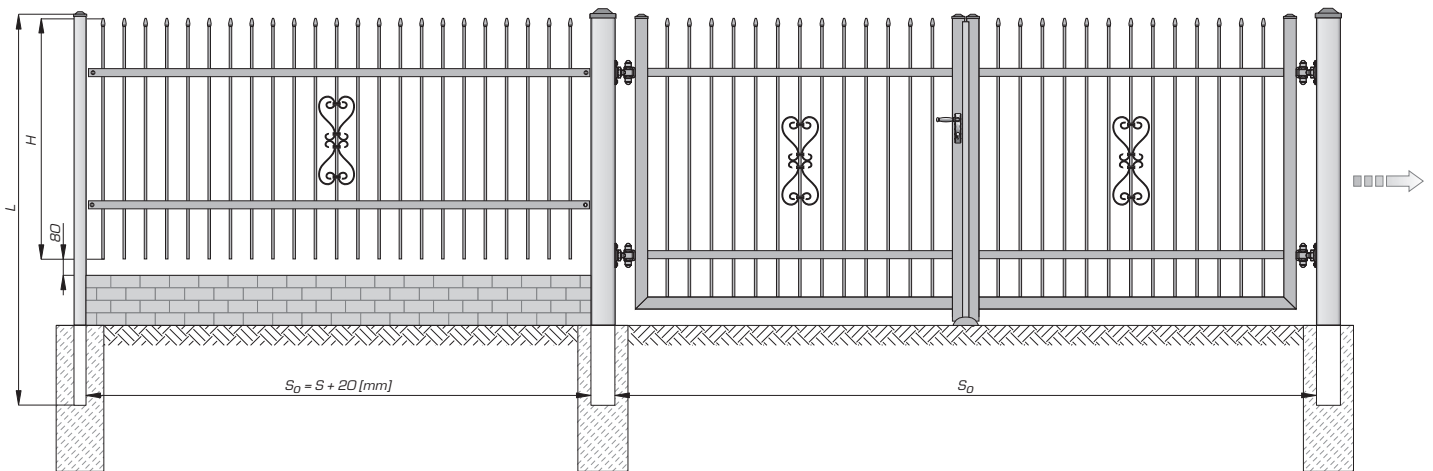
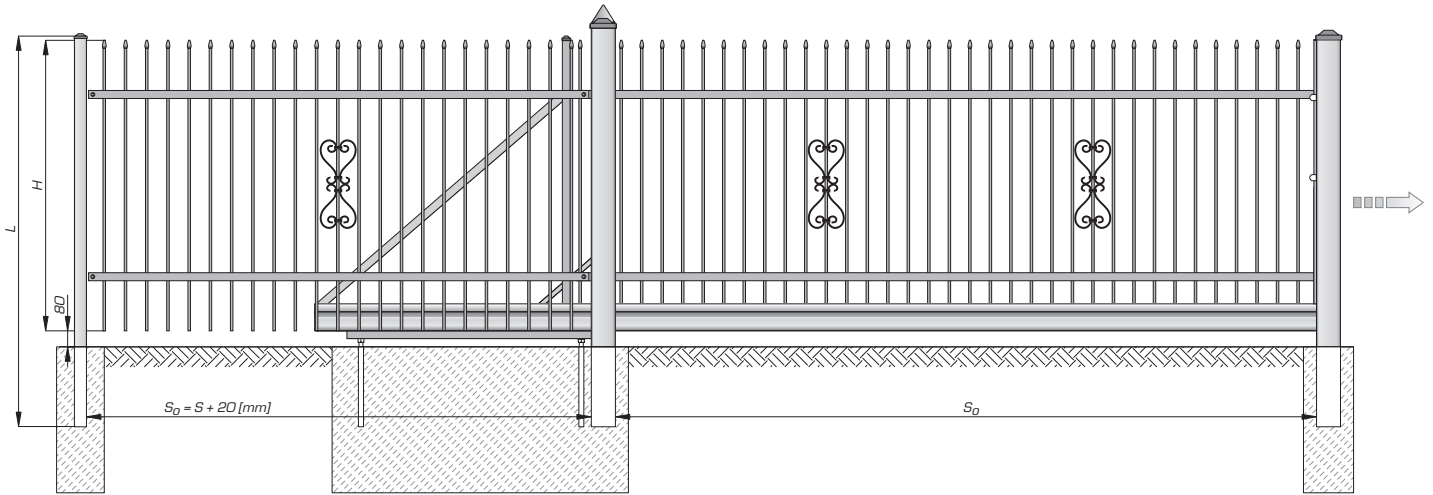

AW.10.09/P

(S) 2500 [mm] x (H) 900 [mm] - 40 kg	(S) 3000 [mm] x (H) 1200 [mm] - 56 kg
(S) 2500 [mm] x (H) 1200 [mm] - 47 kg	(S) 3000 [mm] x (H) 1450 [mm] - 65 kg
(S) 2500 [mm] x (H) 1450 [mm] - 54 kg	
max: (S) 3000 [mm] x (H) 1750 [mm]	

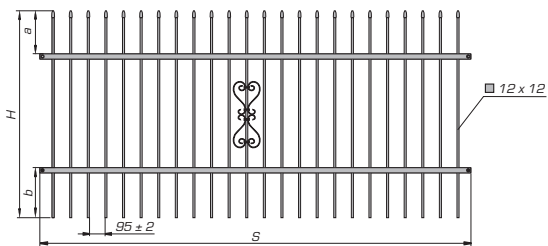

$H \geq 1000$: $a=250$, $b=300$, $H_{min}=800$ $800 \leq H < 1000$: $a=250$, $b=200$, $H_{min}=800$

AW.10.09/Wp

(S) 2500 [mm] x (H) 900 [mm] - 38 kg	(S) 3000 [mm] x (H) 1200 [mm] - 54 kg
(S) 2500 [mm] x (H) 1200 [mm] - 45 kg	(S) 3000 [mm] x (H) 1450 [mm] - 63 kg
(S) 2500 [mm] x (H) 1450 [mm] - 52 kg	
max: (S) 3000 [mm] x (H) 1750 [mm]	

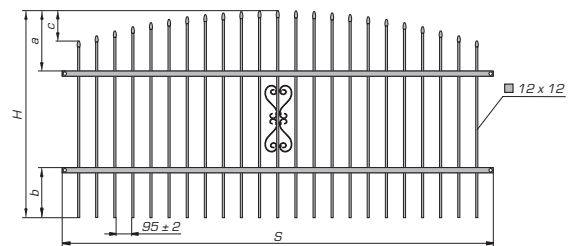

$H \geq 1100$: $a=350$, $b=300$, $c=175$, $H_{min}=900$ $900 \leq H < 1100$: $a=350$, $b=200$, $c=175$, $H_{min}=900$

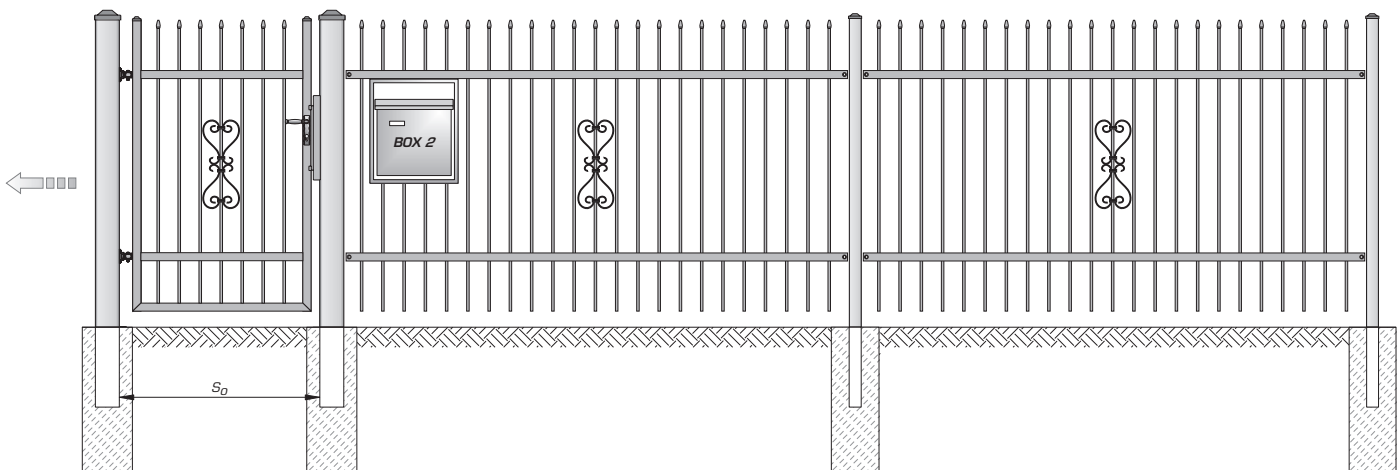
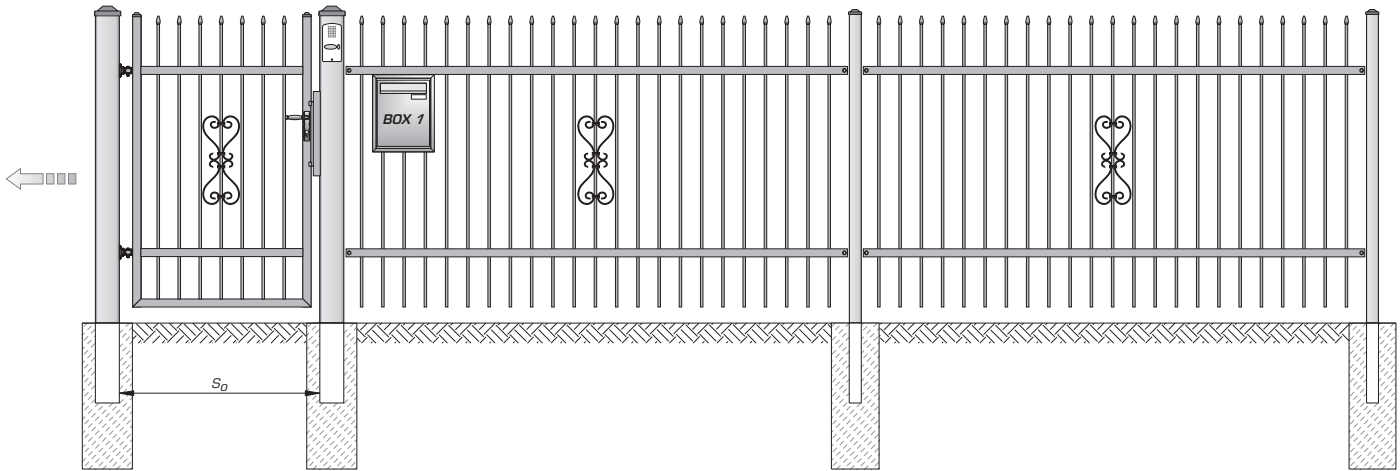

AW.10.09/Wk

(S) 2500 [mm] x (H) 900 [mm] - 38 kg	(S) 3000 [mm] x (H) 1200 [mm] - 54 kg
(S) 2500 [mm] x (H) 1200 [mm] - 45 kg	(S) 3000 [mm] x (H) 1450 [mm] - 63 kg
(S) 2500 [mm] x (H) 1450 [mm] - 52 kg	
max: (S) 3000 [mm] x (H) 1750 [mm]	

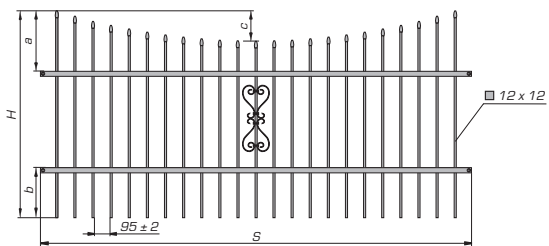

$H \geq 1100$: $a=350$, $b=300$, $c=175$, $H_{min}=900$ $900 \leq H < 1100$: $a=350$, $b=200$, $c=175$, $H_{min}=900$

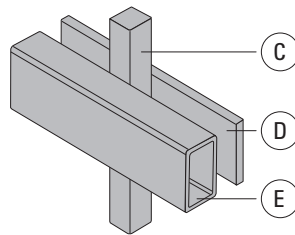

U2

C 12x12 D 30x5 E 30x18

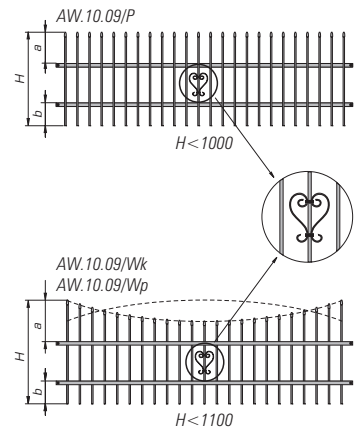



System *Style*
AW.10.12

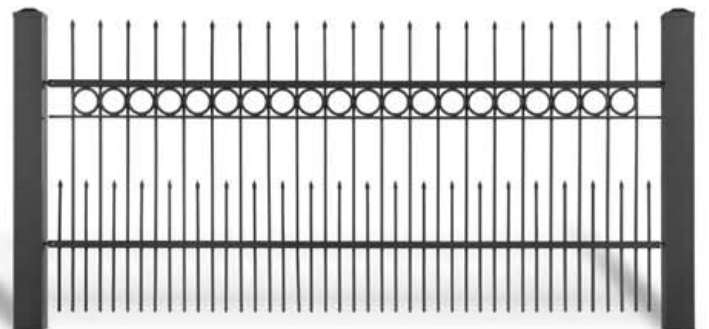
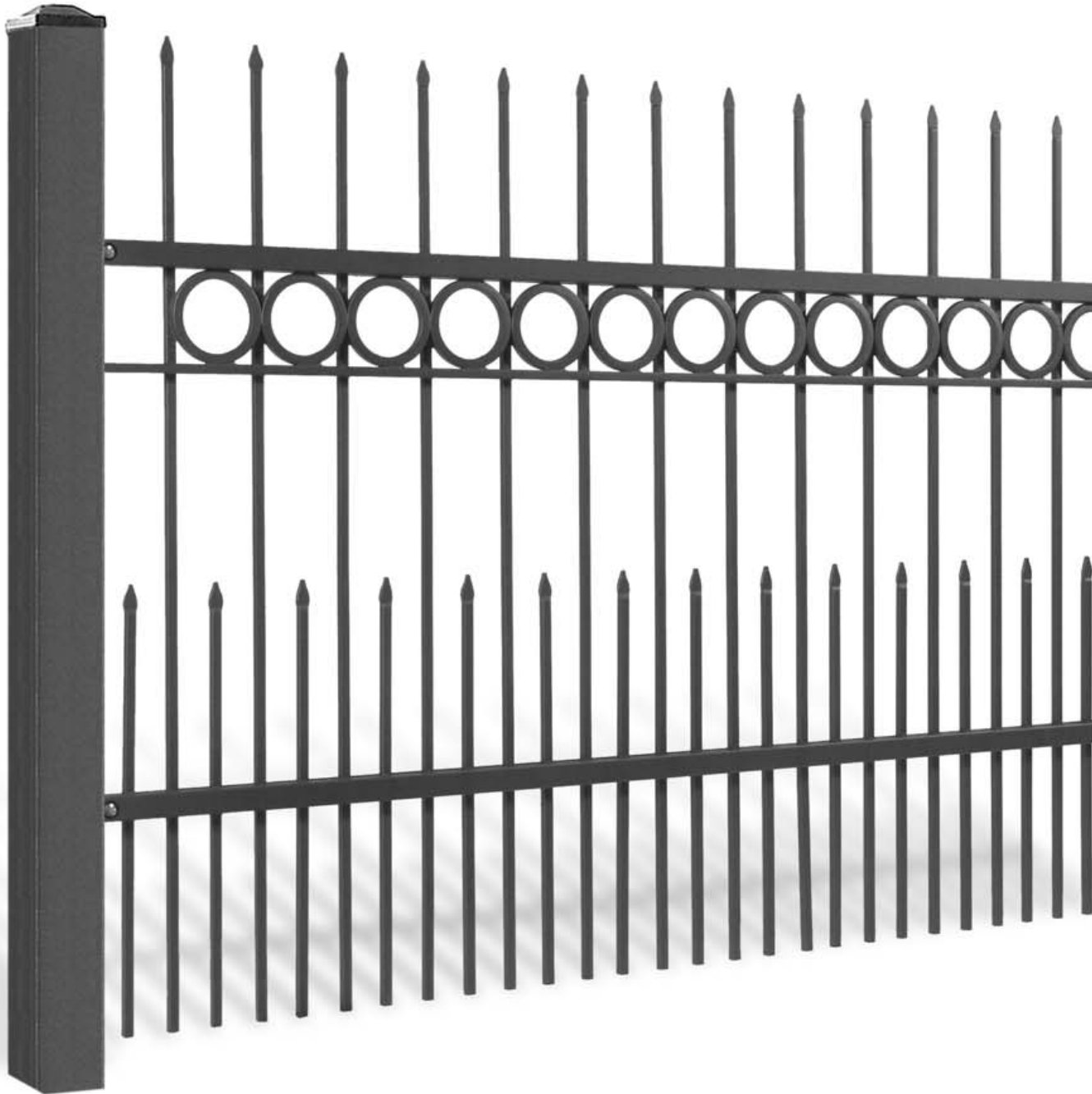

System *Style*
AW.10.12



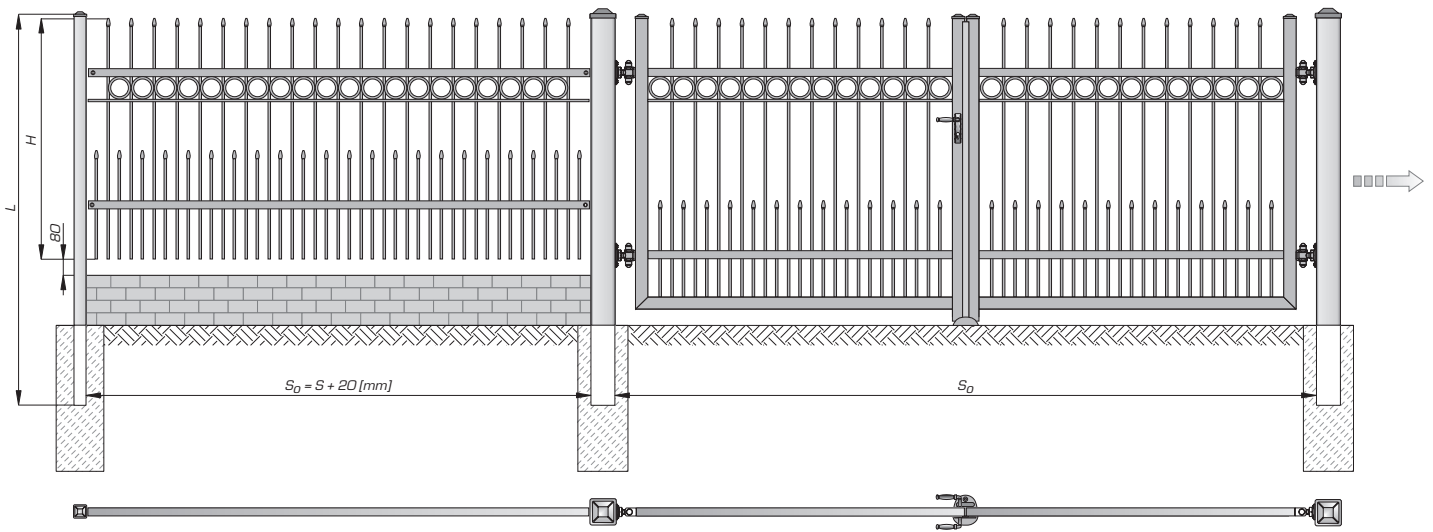
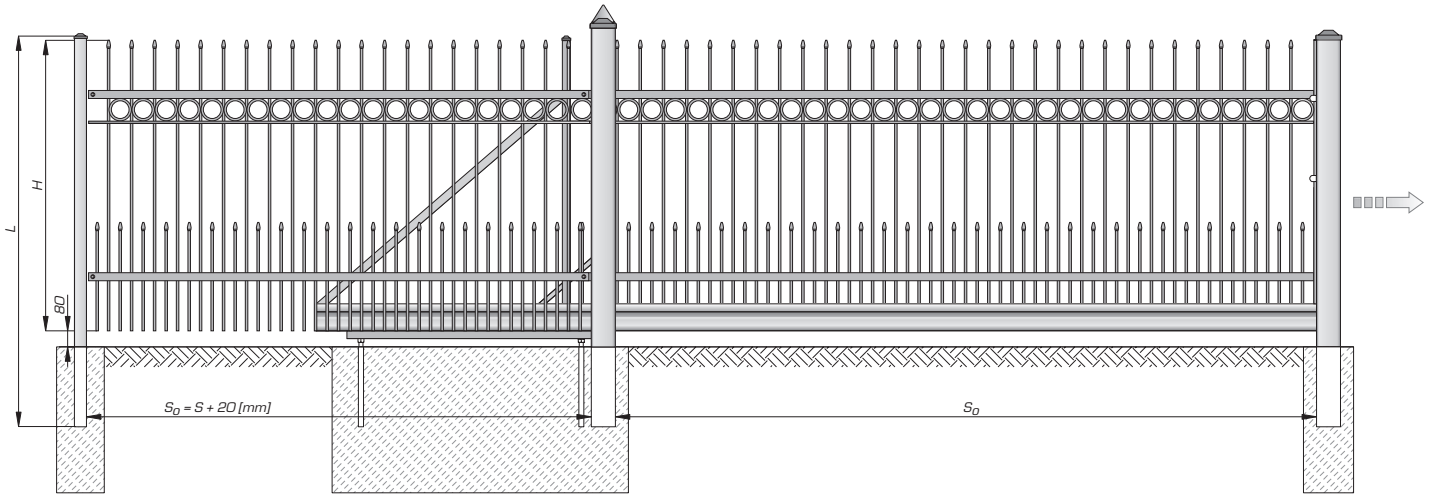

AW.10.12/P

(S) 2500 [mm] x (H) 900 [mm] - 62 kg	(S) 3000 [mm] x (H) 1200 [mm] - 82 kg
(S) 2500 [mm] x (H) 1200 [mm] - 68 kg	(S) 3000 [mm] x (H) 1450 [mm] - 91 kg
(S) 2500 [mm] x (H) 1450 [mm] - 74 kg	
max: (S) 3000 [mm] x (H) 1750 [mm]	

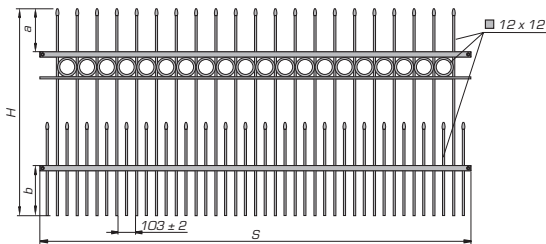

$H \geq 1000$: $a=250$, $b=300$, $H_{min}=800$ $800 \leq H < 1000$: $a=250$, $b=200$, $H_{min}=800$

AW.10.12/Wp

(S) 2500 [mm] x (H) 900 [mm] - 60 kg	(S) 3000 [mm] x (H) 1200 [mm] - 80 kg
(S) 2500 [mm] x (H) 1200 [mm] - 66 kg	(S) 3000 [mm] x (H) 1450 [mm] - 89 kg
(S) 2500 [mm] x (H) 1450 [mm] - 72 kg	
max: (S) 3000 [mm] x (H) 1750 [mm]	

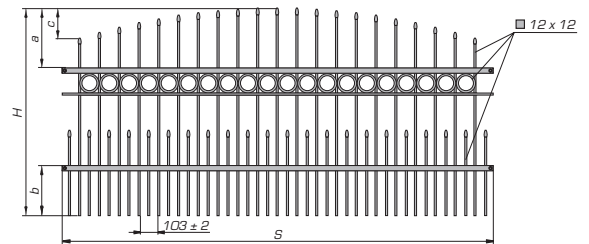

$H \geq 1100$: $a=350$, $b=300$, $c=175$, $H_{min}=900$ $900 \leq H < 1100$: $a=350$, $b=200$, $c=175$, $H_{min}=900$

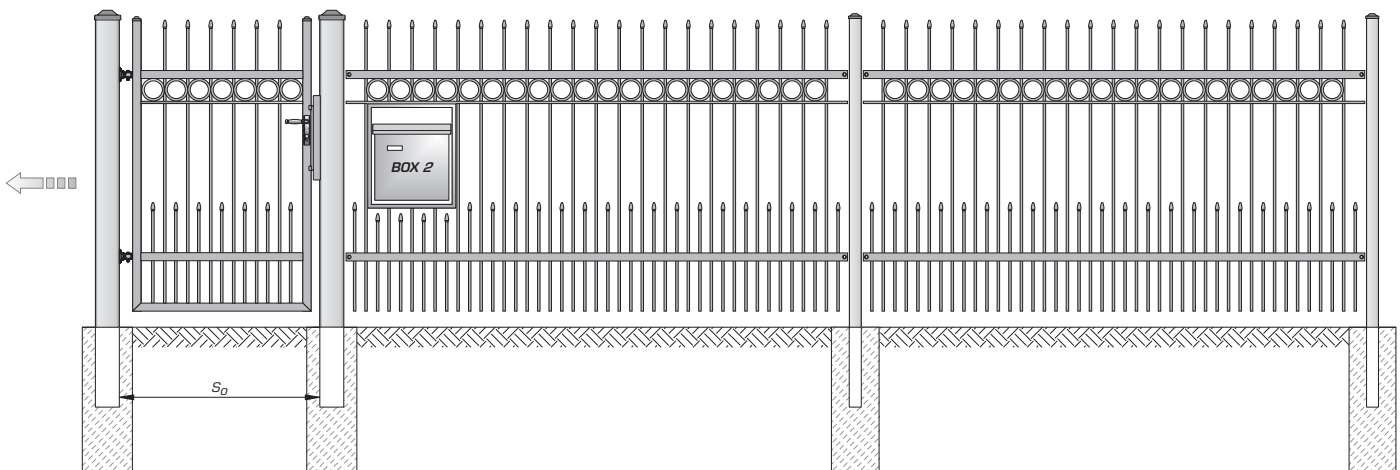
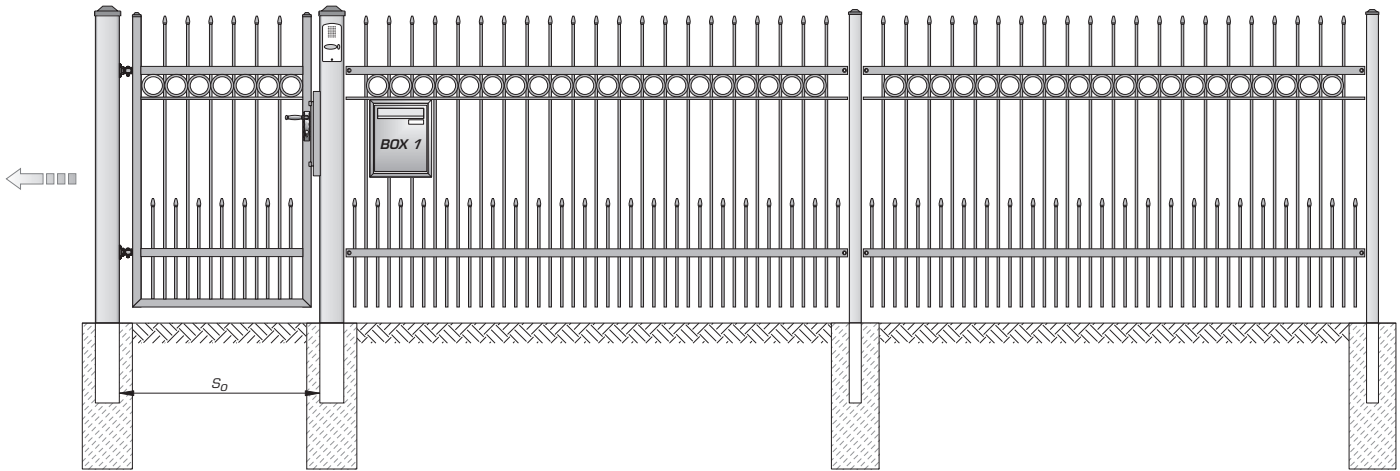

AW.10.12/Wk

(S) 2500 [mm] x (H) 900 [mm] - 60 kg	(S) 3000 [mm] x (H) 1200 [mm] - 80 kg
(S) 2500 [mm] x (H) 1200 [mm] - 66 kg	(S) 3000 [mm] x (H) 1450 [mm] - 89 kg
(S) 2500 [mm] x (H) 1450 [mm] - 72 kg	
max: (S) 3000 [mm] x (H) 1750 [mm]	

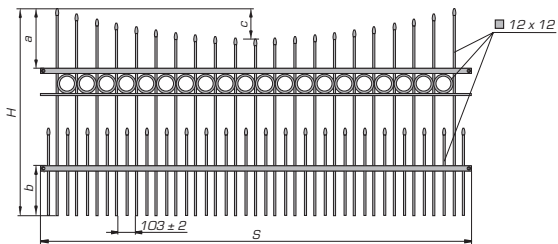

$H \geq 1100$: a=350, b=300, c=175, $H_{min}=900$ $900 \leq H < 1100$: a=350, b=200, c=175, $H_{min}=900$

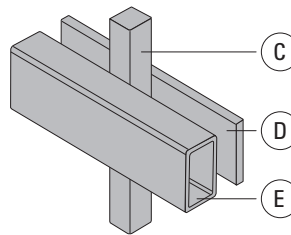

U2

(C) 12x12 (D) 30x5 (E) 30x18

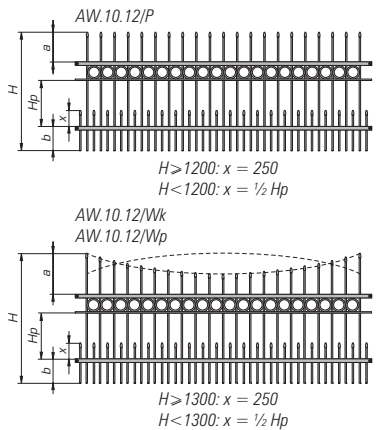



System *Style*
AW.10.14

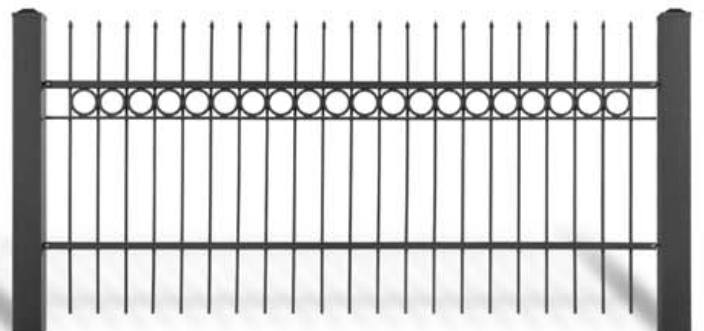
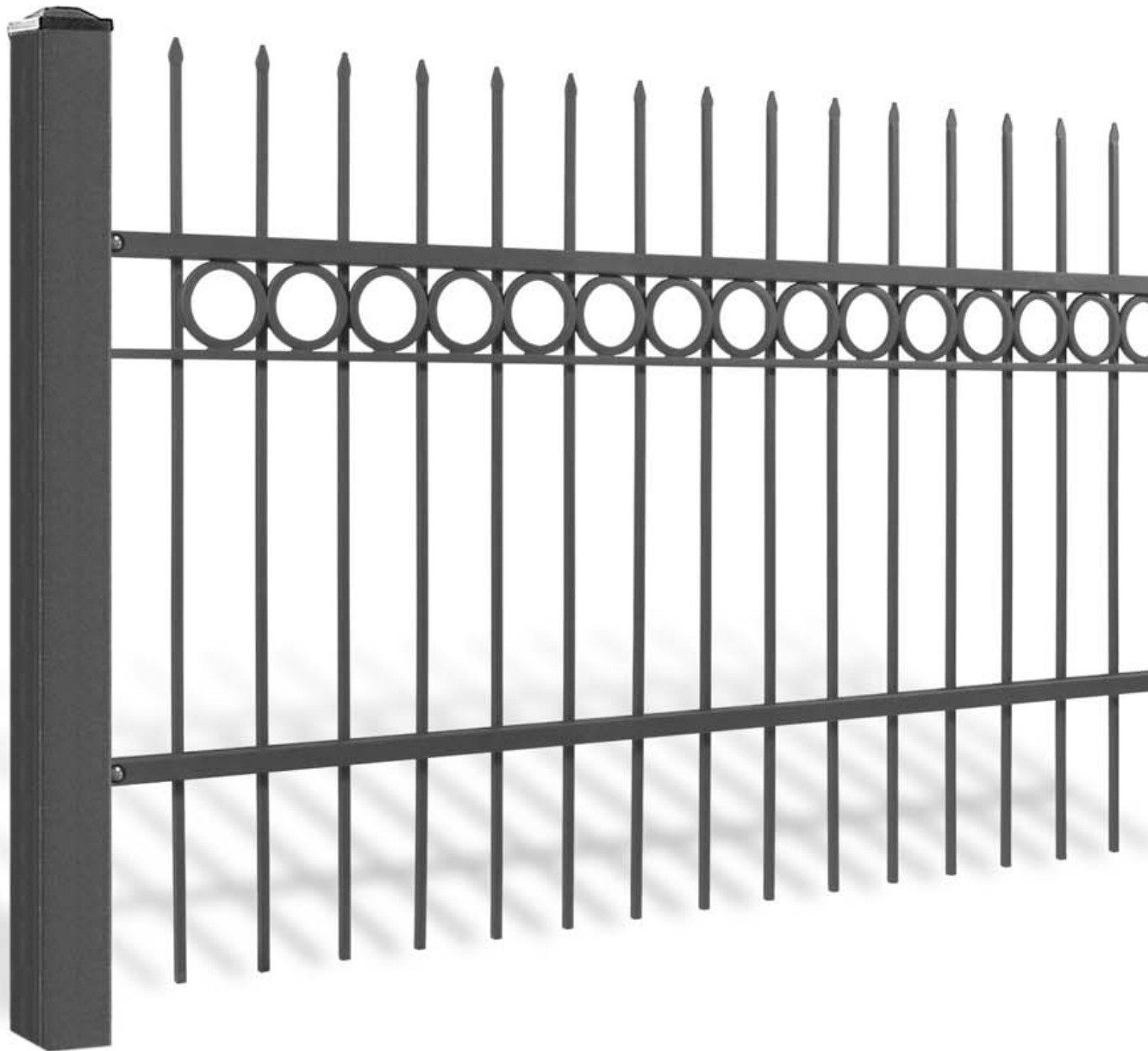

System *Style*
AW.10.14



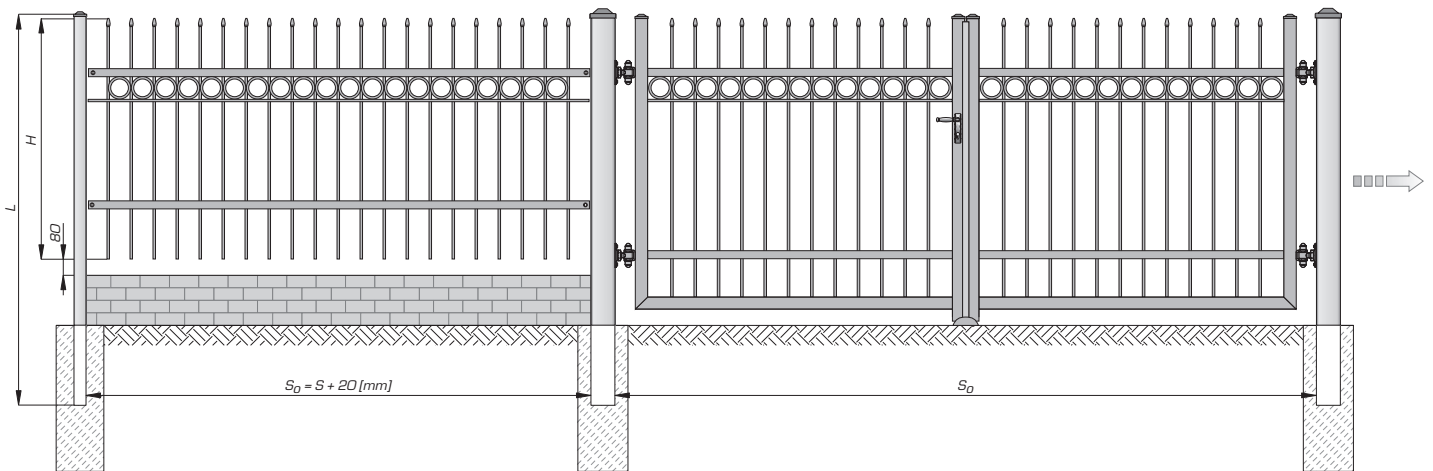
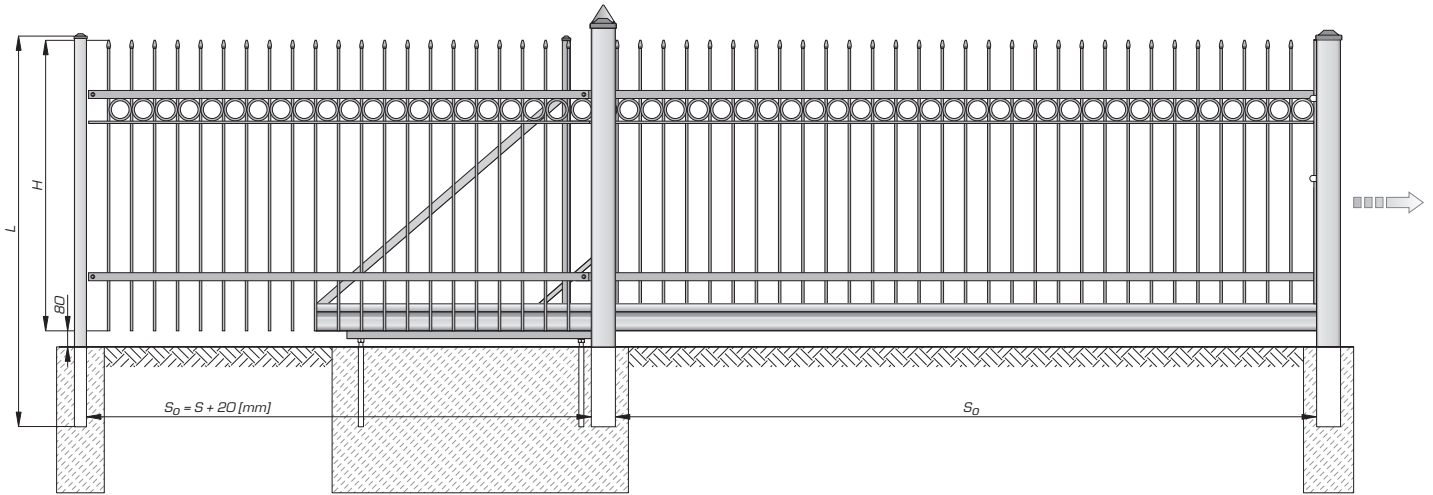

AW.10.14/P

(S) 2500 [mm] x (H) 900 [mm] - 47 kg	(S) 3000 [mm] x (H) 1200 [mm] - 66 kg
(S) 2500 [mm] x (H) 1200 [mm] - 54 kg	(S) 3000 [mm] x (H) 1450 [mm] - 74 kg
(S) 2500 [mm] x (H) 1450 [mm] - 61 kg	
max: (S) 3000 [mm] x (H) 1750 [mm]	

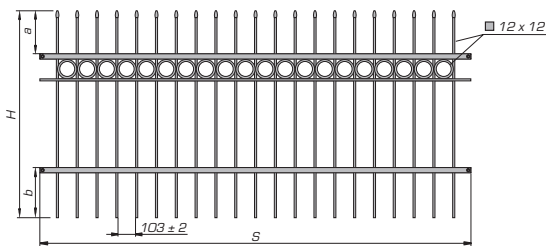

$H \geq 1000$: $a=250$, $b=300$, $H_{min}=800$ $800 \leq H < 1000$: $a=250$, $b=200$, $H_{min}=800$

AW.10.14/Wp

(S) 2500 [mm] x (H) 900 [mm] - 45 kg	(S) 3000 [mm] x (H) 1200 [mm] - 64 kg
(S) 2500 [mm] x (H) 1200 [mm] - 52 kg	(S) 3000 [mm] x (H) 1450 [mm] - 72 kg
(S) 2500 [mm] x (H) 1450 [mm] - 59 kg	
max: (S) 3000 [mm] x (H) 1750 [mm]	

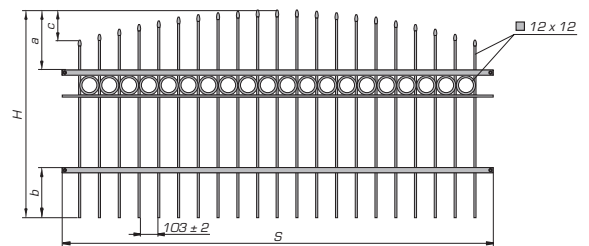

$H \geq 1100$: $a=350$, $b=300$, $c=175$, $H_{min}=900$ $900 \leq H < 1100$: $a=350$, $b=200$, $c=175$, $H_{min}=900$

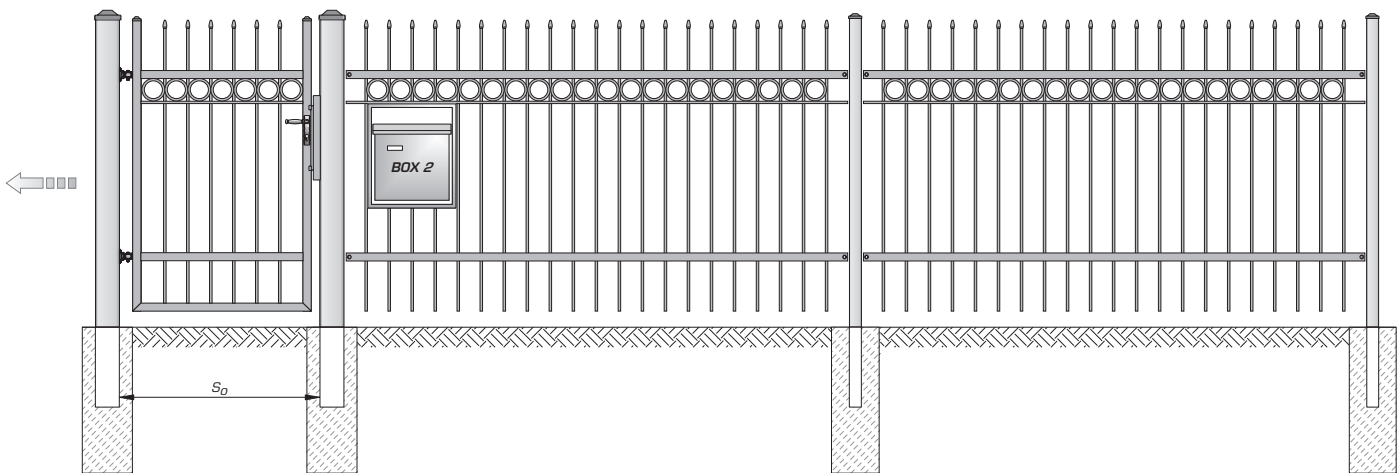
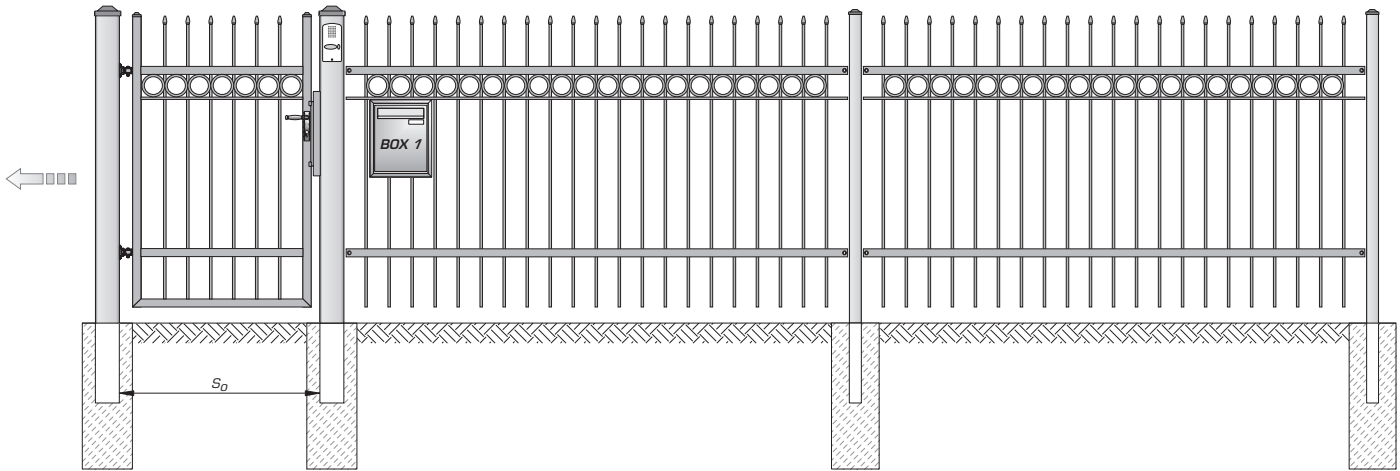

AW.10.14/Wk

(S) 2500 [mm] x (H) 900 [mm] - 45 kg	(S) 3000 [mm] x (H) 1200 [mm] - 64 kg
(S) 2500 [mm] x (H) 1200 [mm] - 52 kg	(S) 3000 [mm] x (H) 1450 [mm] - 72 kg
(S) 2500 [mm] x (H) 1450 [mm] - 59 kg	
max: (S) 3000 [mm] x (H) 1750 [mm]	

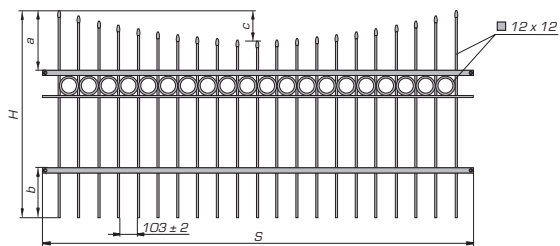

$H \geq 1100$: $a=350$, $b=300$, $c=175$, $H_{min}=900$ $900 \leq H < 1100$: $a=350$, $b=200$, $c=175$, $H_{min}=900$

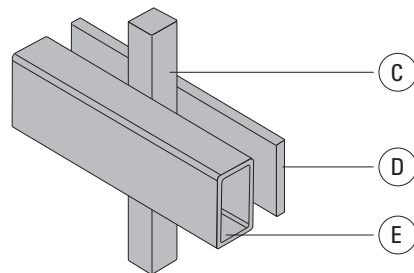

U2 C 12x12 D 30x5 E 30x18



System *Style*
AW.10.15

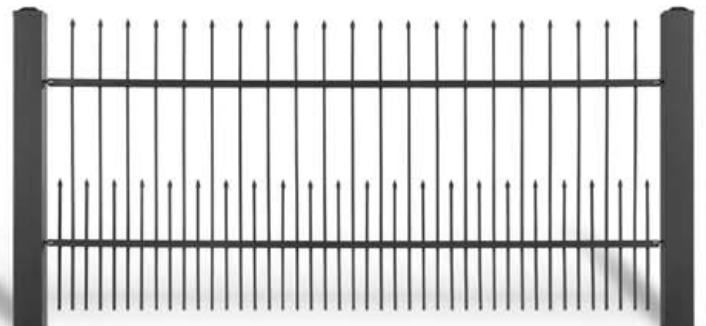

System *Style*
AW.10.15



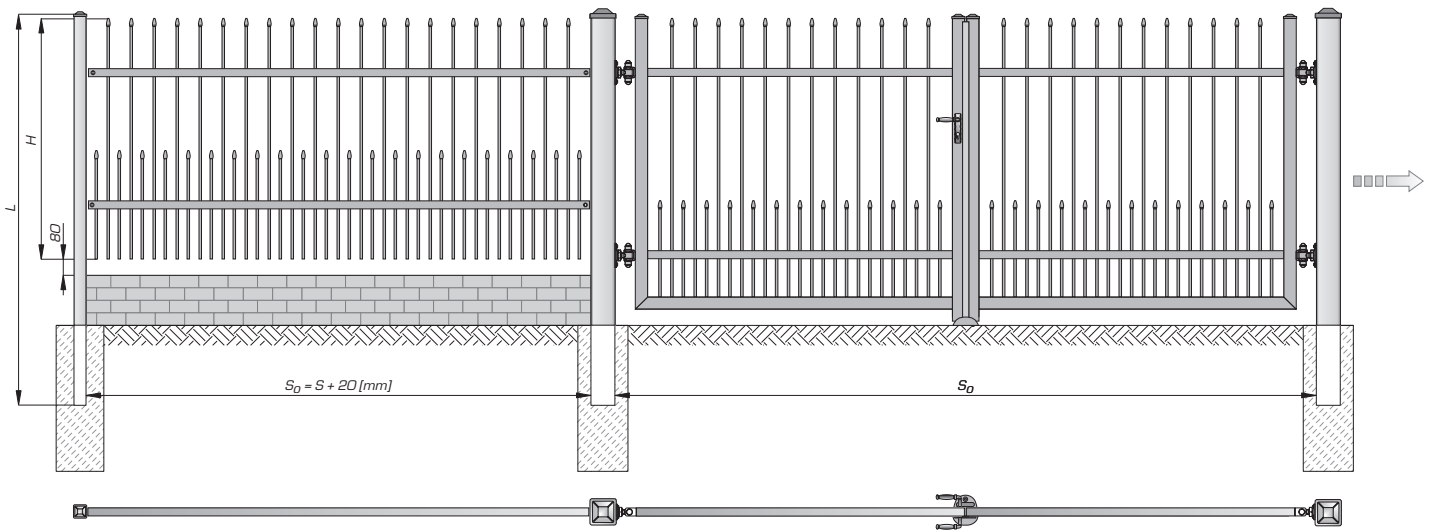
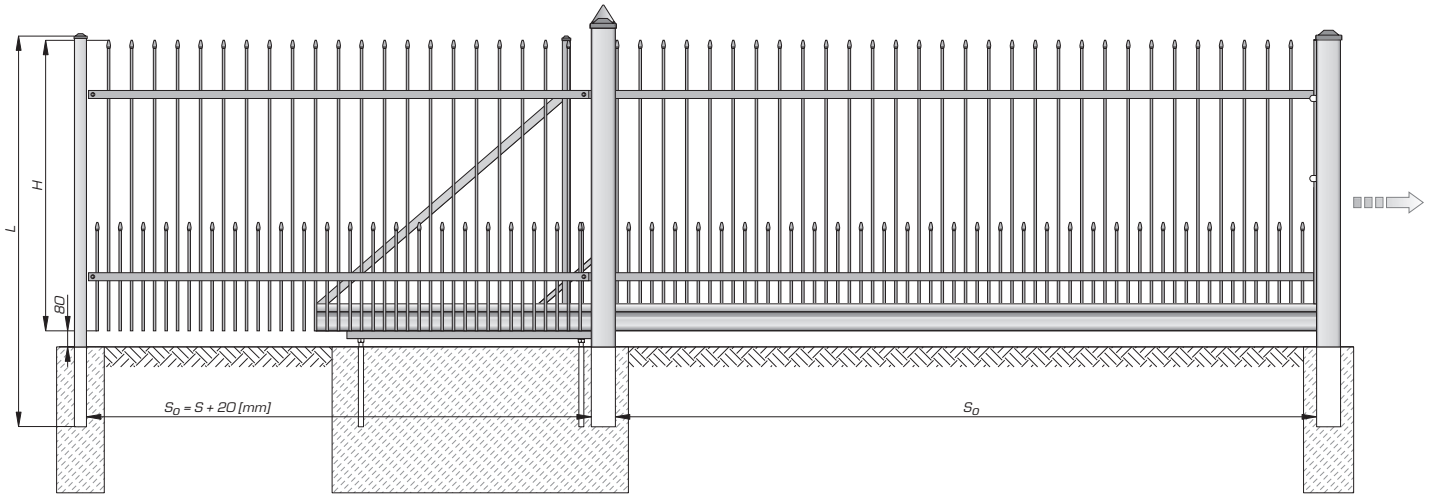

AW.10.15/P

(S) 2500 [mm] x (H) 900 [mm] - 51 kg	(S) 3000 [mm] x (H) 1200 [mm] - 70 kg
(S) 2500 [mm] x (H) 1200 [mm] - 57 kg	(S) 3000 [mm] x (H) 1450 [mm] - 77 kg
(S) 2500 [mm] x (H) 1450 [mm] - 63 kg	
max: (S) 3000 [mm] x (H) 1750 [mm]	

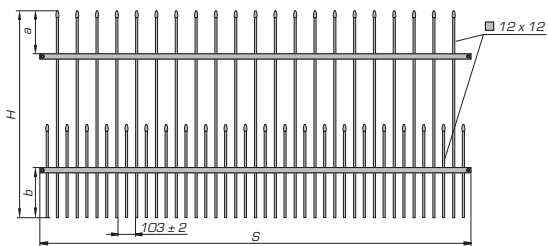

$H \geq 1000$: $a=250$, $b=300$, $H_{min}=800$ $800 \leq H < 1000$: $a=250$, $b=200$, $H_{min}=800$

AW.10.15/Wp

(S) 2500 [mm] x (H) 900 [mm] - 49 kg	(S) 3000 [mm] x (H) 1200 [mm] - 68 kg
(S) 2500 [mm] x (H) 1200 [mm] - 55 kg	(S) 3000 [mm] x (H) 1450 [mm] - 75 kg
(S) 2500 [mm] x (H) 1450 [mm] - 61 kg	
max: (S) 3000 [mm] x (H) 1750 [mm]	

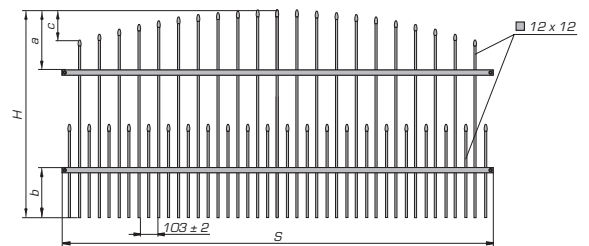

$H \geq 1100$: $a=350$, $b=300$, $c=175$, $H_{min}=900$ $900 \leq H < 1100$: $a=350$, $b=200$, $c=175$, $H_{min}=900$

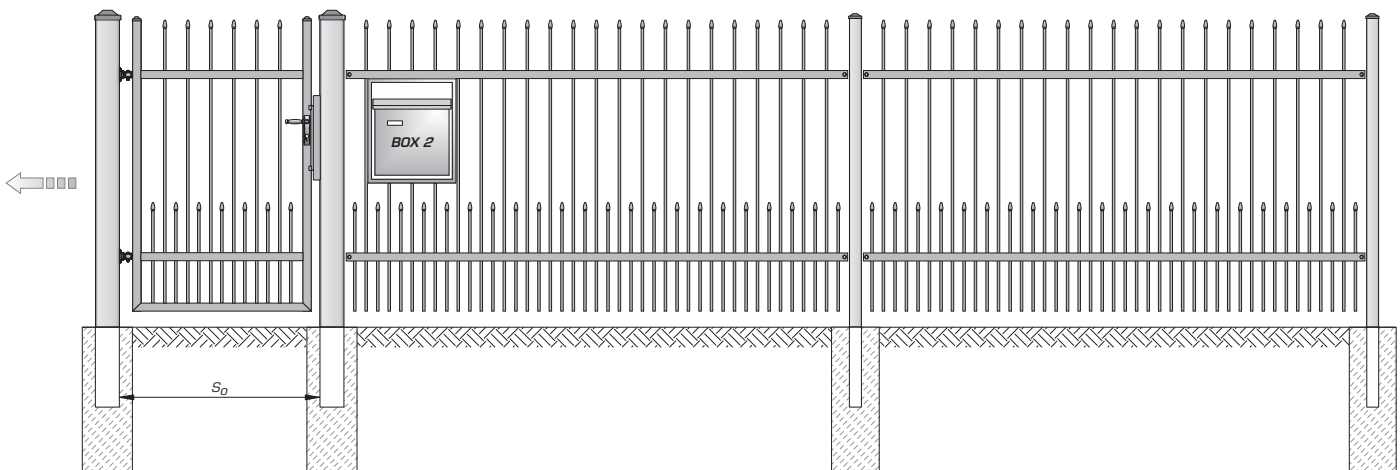
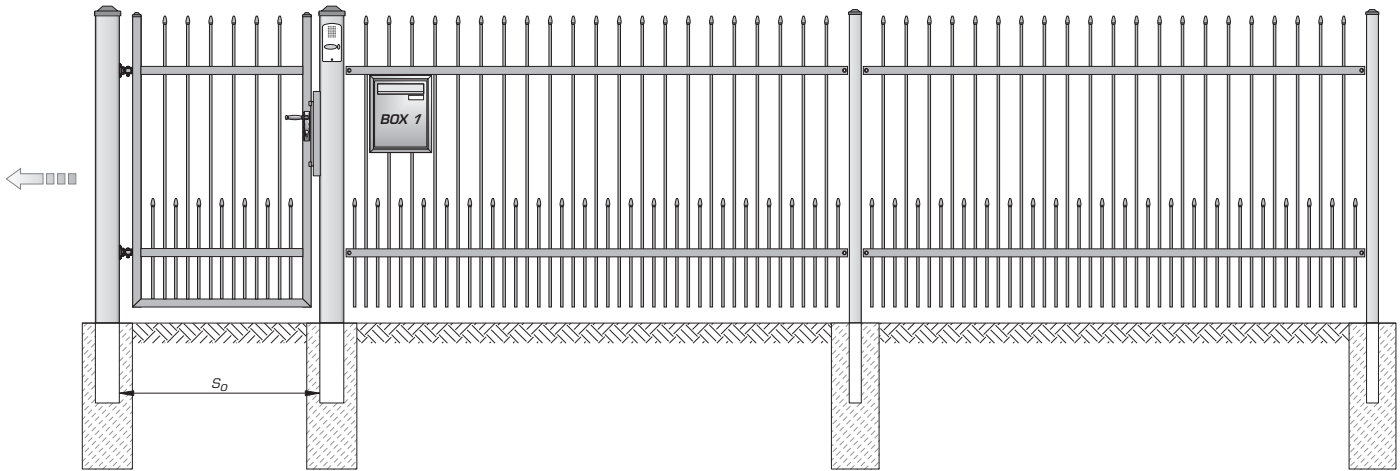

AW.10.15/Wk

(S) 2500 [mm] x (H) 900 [mm] - 49 kg	(S) 3000 [mm] x (H) 1200 [mm] - 68 kg
(S) 2500 [mm] x (H) 1200 [mm] - 55 kg	(S) 3000 [mm] x (H) 1450 [mm] - 75 kg
(S) 2500 [mm] x (H) 1450 [mm] - 61 kg	
max: (S) 3000 [mm] x (H) 1750 [mm]	

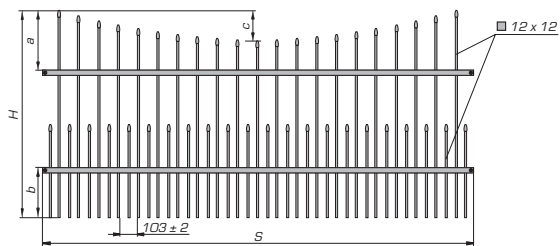

$H \geq 1100$: a=350, b=300, c=175, $H_{min}=900$ $900 \leq H < 1100$: a=350, b=200, c=175, $H_{min}=900$

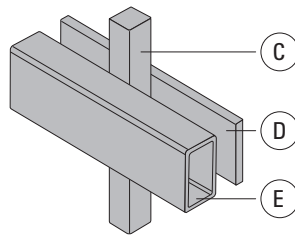

U2

C 12x12 D 30x5 E 30x18

AW.10.15/P

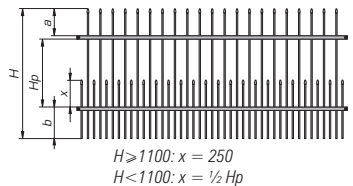

AW.10.15/Wk
AW.10.15/Wp

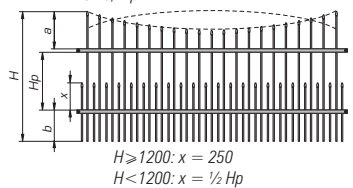



System *Style*
AW.10.22

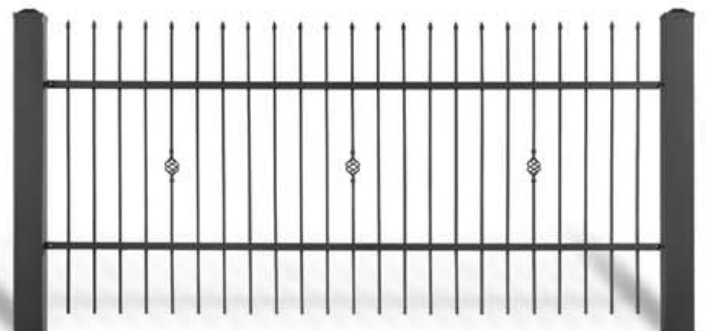
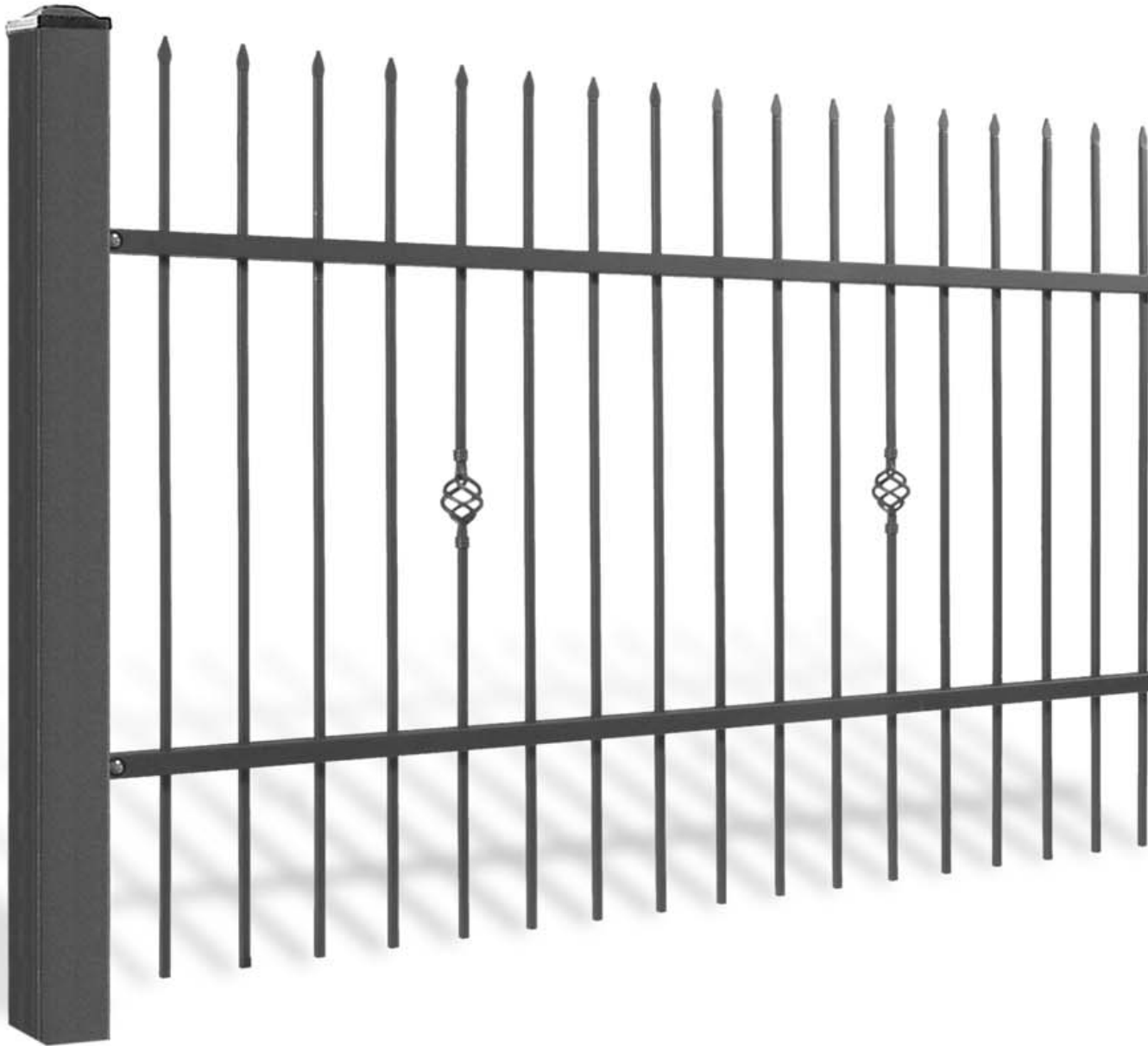

System *Style*
AW.10.22



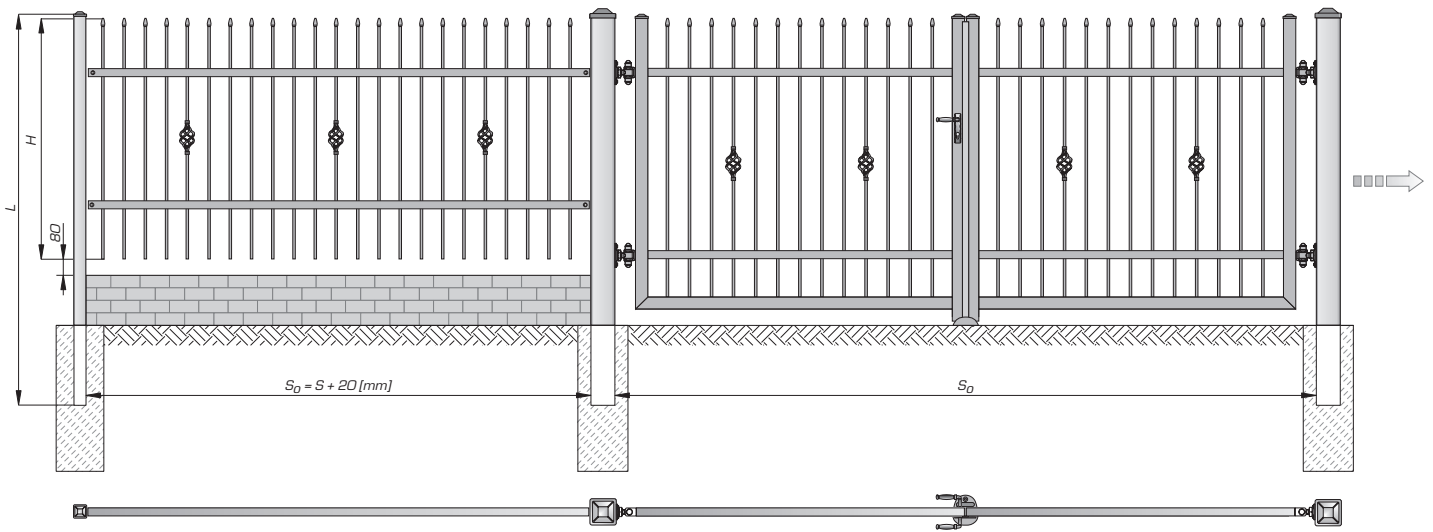
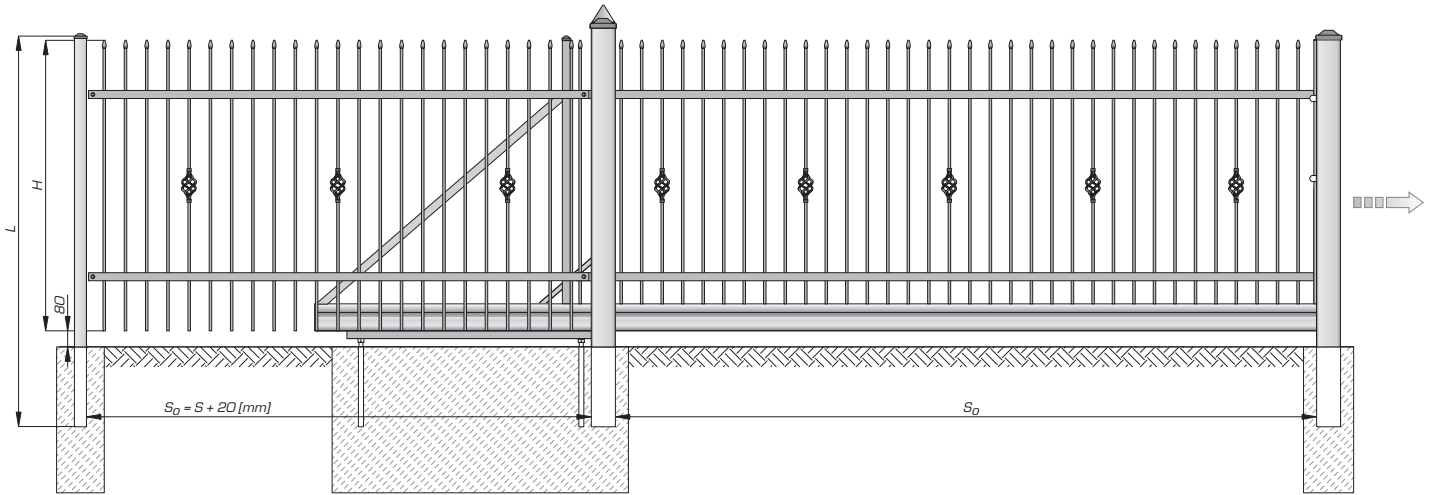

AW.10.22/P

(S) 2500 [mm] x (H) 900 [mm] - 40 kg	(S) 3000 [mm] x (H) 1200 [mm] - 56 kg
(S) 2500 [mm] x (H) 1200 [mm] - 47 kg	(S) 3000 [mm] x (H) 1450 [mm] - 65 kg
(S) 2500 [mm] x (H) 1450 [mm] - 54 kg	
max: (S) 3000 [mm] x (H) 1750 [mm]	

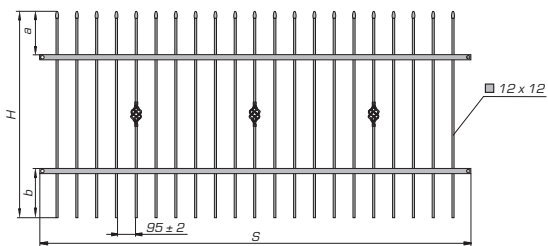

$H \geq 1000$: $a=250$, $b=300$, $H_{min}=800$ $800 \leq H < 1000$: $a=250$, $b=200$, $H_{min}=800$

AW.10.22/Wp

(S) 2500 [mm] x (H) 900 [mm] - 38 kg	(S) 3000 [mm] x (H) 1200 [mm] - 54 kg
(S) 2500 [mm] x (H) 1200 [mm] - 45 kg	(S) 3000 [mm] x (H) 1450 [mm] - 63 kg
(S) 2500 [mm] x (H) 1450 [mm] - 52 kg	
max: (S) 3000 [mm] x (H) 1750 [mm]	

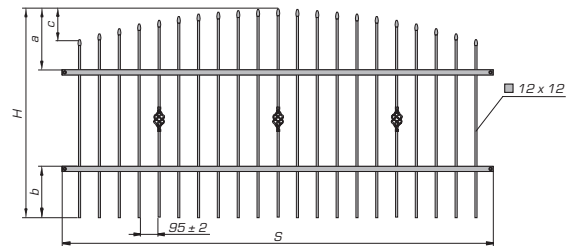

$H \geq 1100$: $a=350$, $b=300$, $c=175$, $H_{min}=900$ $900 \leq H < 1100$: $a=350$, $b=200$, $c=175$, $H_{min}=900$

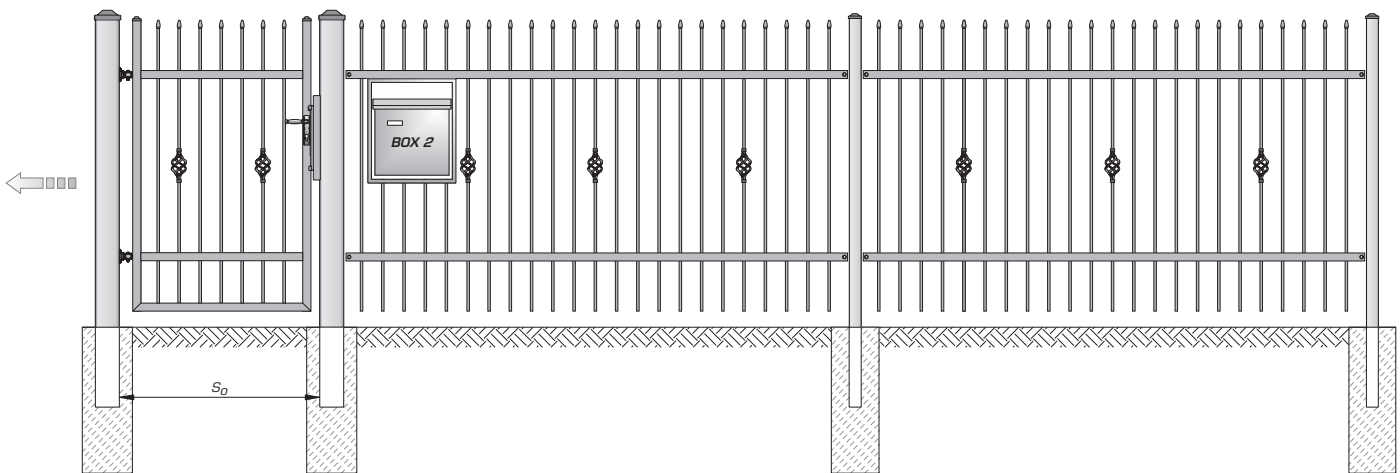
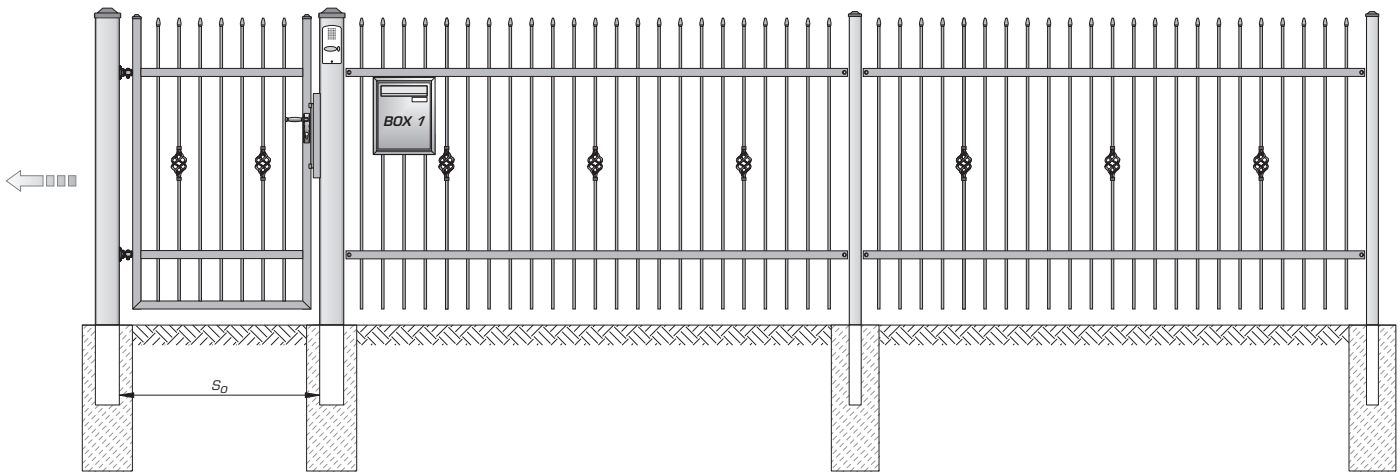

AW.10.22/Wk

(S) 2500 [mm] x (H) 900 [mm] - 38 kg	(S) 3000 [mm] x (H) 1200 [mm] - 54 kg
(S) 2500 [mm] x (H) 1200 [mm] - 45 kg	(S) 3000 [mm] x (H) 1450 [mm] - 63 kg
(S) 2500 [mm] x (H) 1450 [mm] - 52 kg	
max: (S) 3000 [mm] x (H) 1750 [mm]	

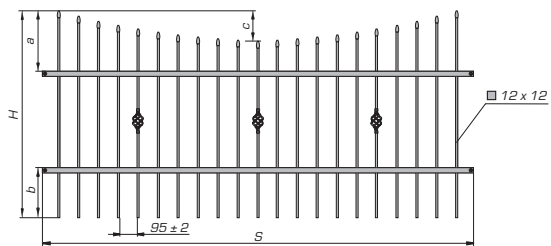

$H \geq 1100$: $a=350$, $b=300$, $c=175$, $H_{min}=900$ $900 \leq H < 1100$: $a=350$, $b=200$, $c=175$, $H_{min}=900$

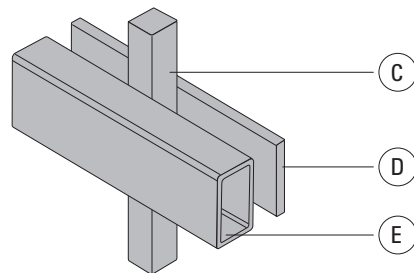

U2 C 12x12 D 30x5 E 30x18



System *Style*
AW.10.23

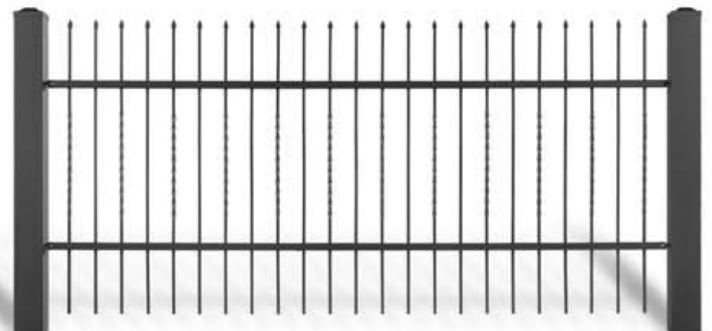

System *Style*
AW.10.23

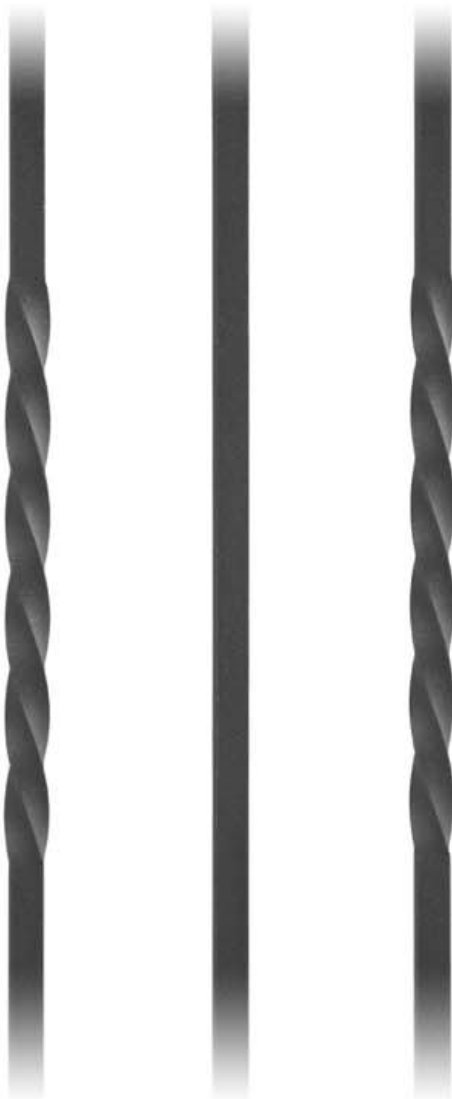

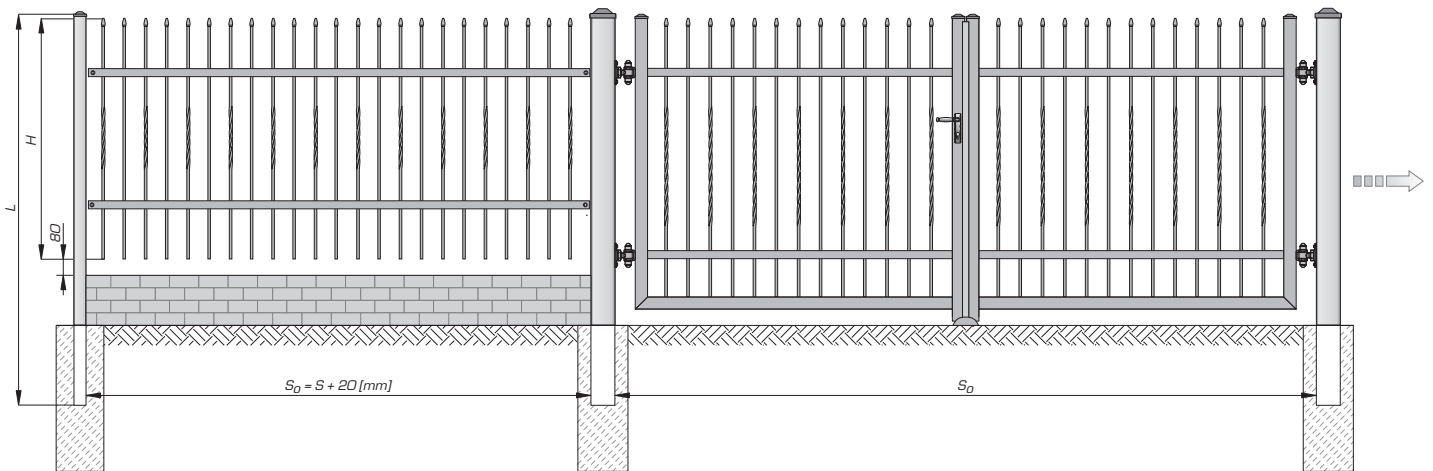
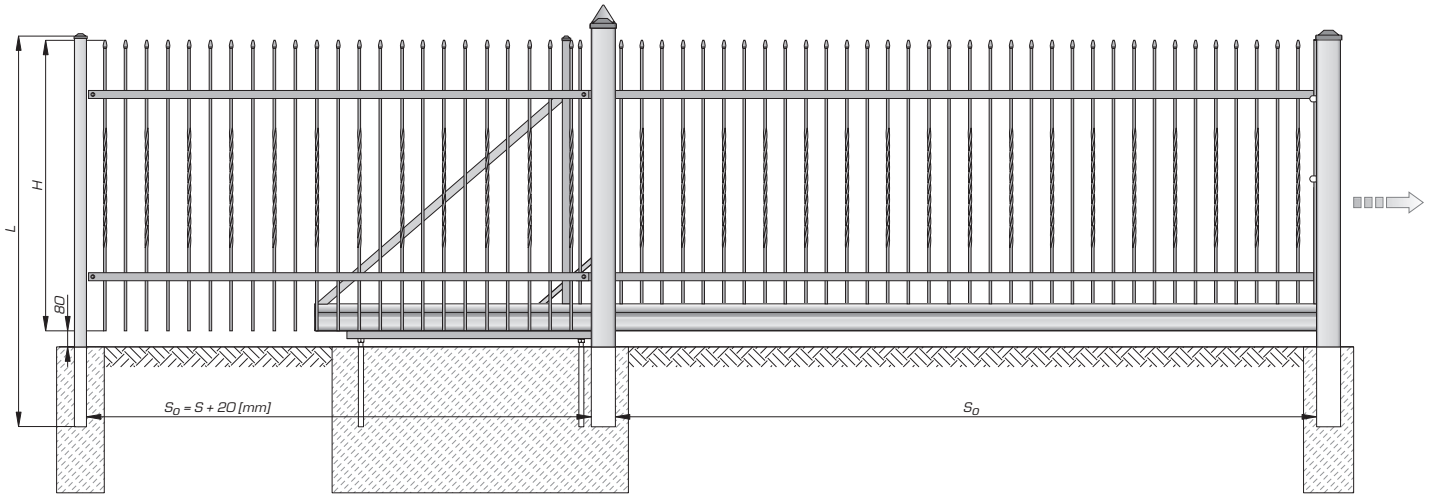

AW.10.23/P

(S) 2500 [mm] x (H) 900 [mm] - 38 kg	(S) 3000 [mm] x (H) 1200 [mm] - 56 kg
(S) 2500 [mm] x (H) 1200 [mm] - 46 kg	(S) 3000 [mm] x (H) 1450 [mm] - 64 kg
(S) 2500 [mm] x (H) 1450 [mm] - 54 kg	
max: (S) 3000 [mm] x (H) 1750 [mm]	

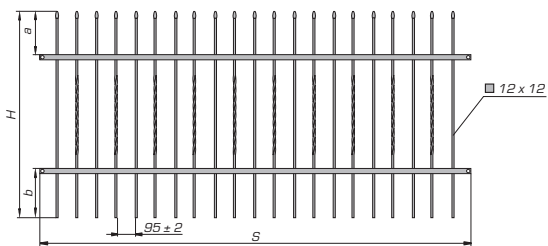

$H \geq 1000$: $a=250$, $b=300$, $H_{min}=900$ $900 \leq H < 1000$: $a=250$, $b=200$, $H_{min}=900$

AW.10.23/Wp

(S) 2500 [mm] x (H) 1200 [mm] - 44 kg	(S) 3000 [mm] x (H) 1200 [mm] - 54 kg
(S) 2500 [mm] x (H) 1450 [mm] - 52 kg	(S) 3000 [mm] x (H) 1450 [mm] - 62 kg
max: (S) 3000 [mm] x (H) 1750 [mm]	

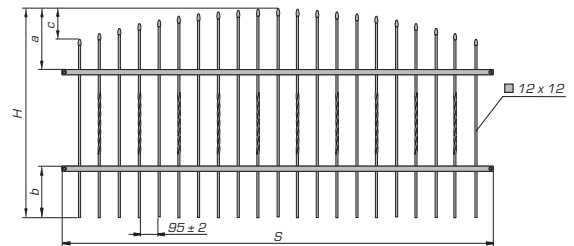

$H \geq 1100$: $a=350$, $b=300$, $c=175$, $H_{min}=1000$ $1000 \leq H < 1100$: $a=350$, $b=200$, $c=175$, $H_{min}=1000$

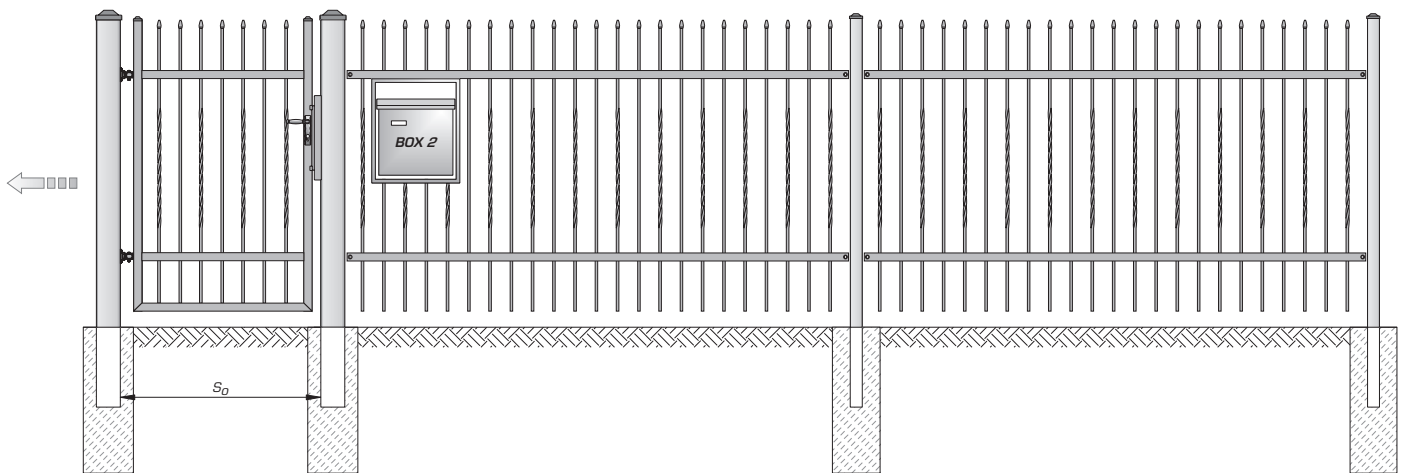
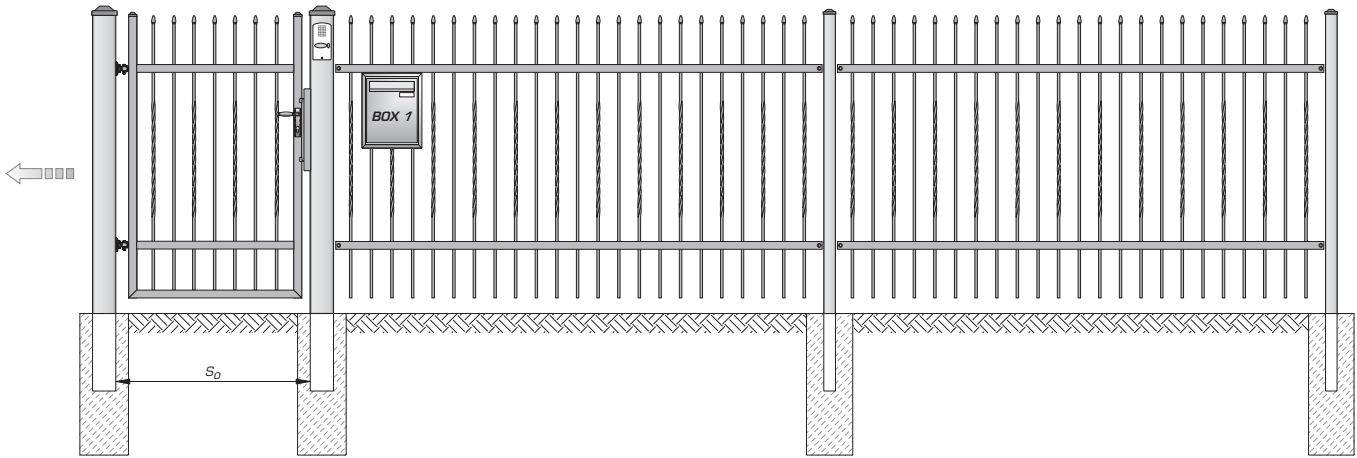

AW.10.23/Wk

(S) 2500 [mm] x (H) 1200 [mm] - 44 kg	(S) 3000 [mm] x (H) 1200 [mm] - 54 kg
(S) 2500 [mm] x (H) 1450 [mm] - 52 kg	(S) 3000 [mm] x (H) 1450 [mm] - 62 kg
max: (S) 3000 [mm] x (H) 1750 [mm]	

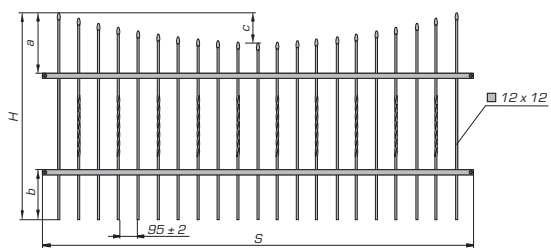

$H \geq 1100$: $a=350, b=300, c=175, H_{min}=1000$ $1000 \leq H < 1100$: $a=350, b=200, c=175, H_{min}=1000$

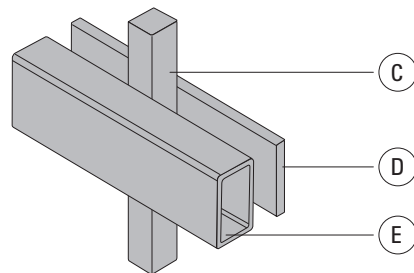

U2 C 12x12 D 30x5 E 30x18



System *Style*
AW.10.24

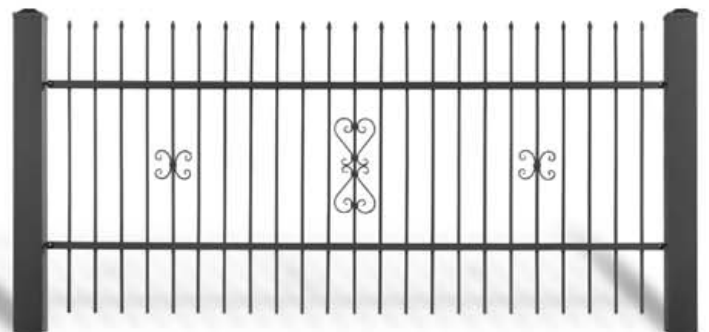

System *Style*
AW.10.24

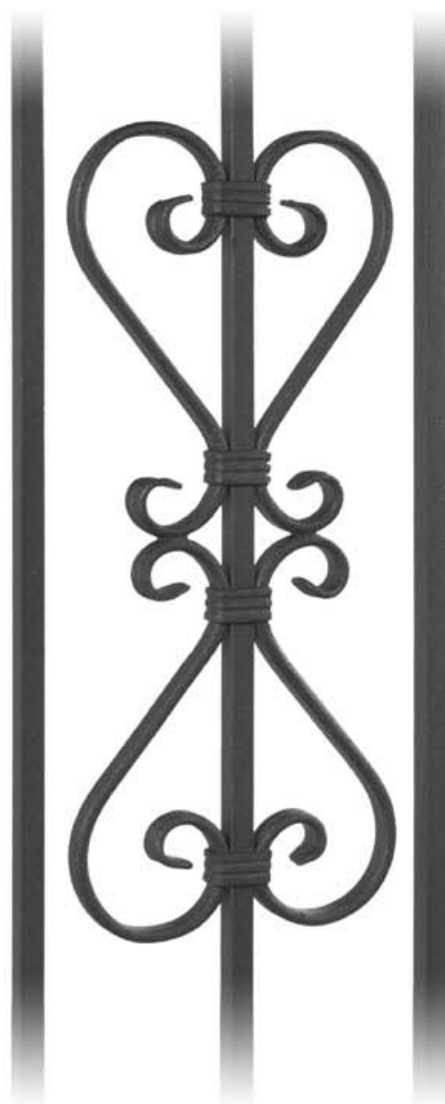

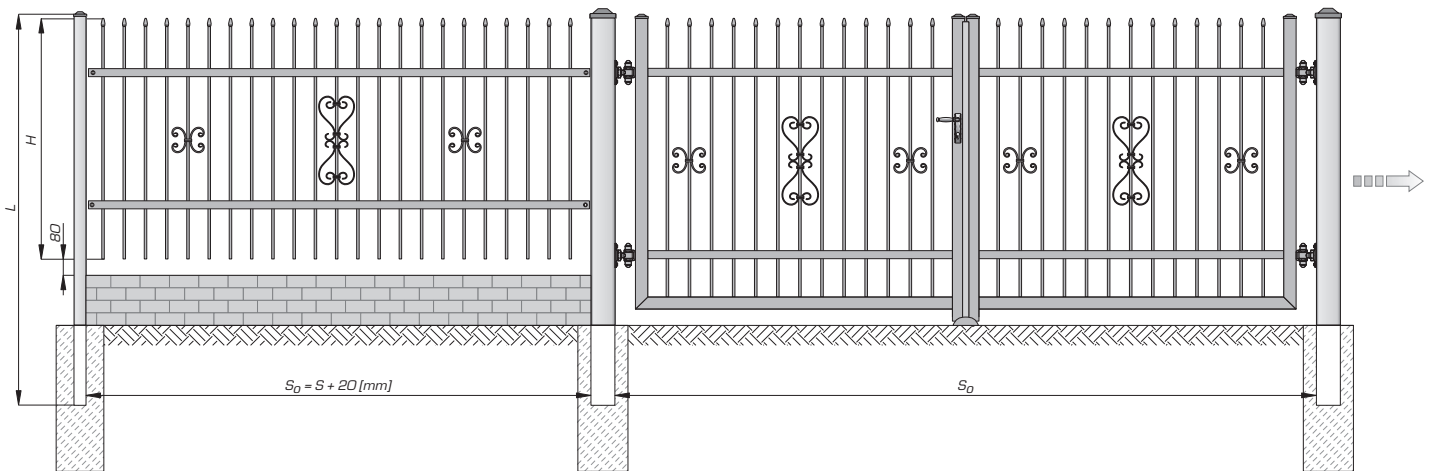
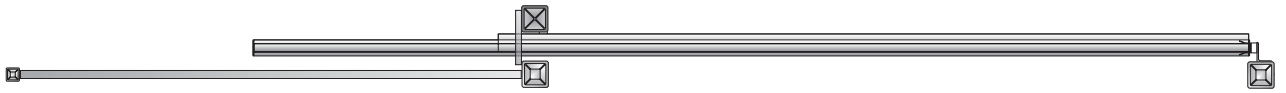
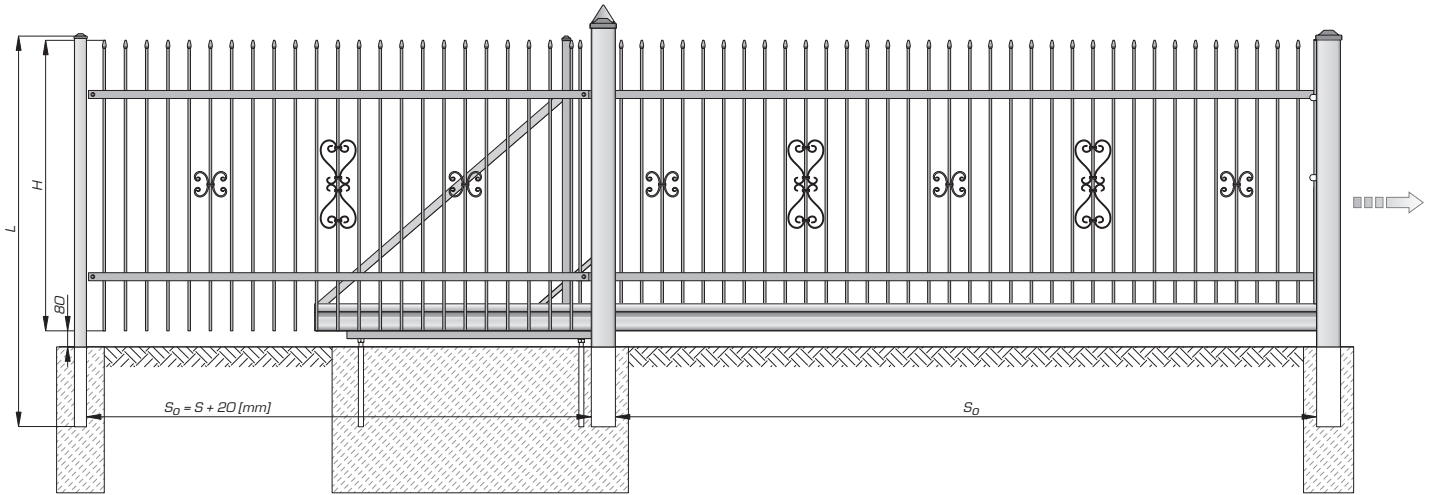

AW.10.24/P

(S) 2500 [mm] x (H) 900 [mm] - 41 kg	(S) 3000 [mm] x (H) 1200 [mm] - 57 kg
(S) 2500 [mm] x (H) 1200 [mm] - 48 kg	(S) 3000 [mm] x (H) 1450 [mm] - 66 kg
(S) 2500 [mm] x (H) 1450 [mm] - 55 kg	
max: (S) 3000 [mm] x (H) 1750 [mm]	

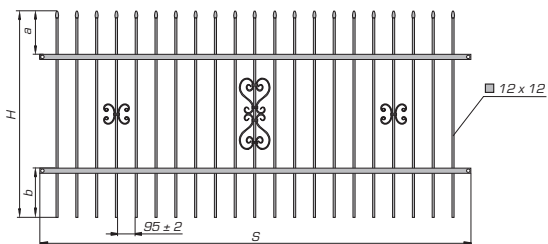

$H \geq 1000$: $a=250$, $b=300$, $H_{min}=800$ $800 \leq H < 1000$: $a=250$, $b=200$, $H_{min}=800$

AW.10.24/Wp

(S) 2500 [mm] x (H) 900 [mm] - 39 kg	(S) 3000 [mm] x (H) 1200 [mm] - 55 kg
(S) 2500 [mm] x (H) 1200 [mm] - 46 kg	(S) 3000 [mm] x (H) 1450 [mm] - 64 kg
(S) 2500 [mm] x (H) 1450 [mm] - 53 kg	
max: (S) 3000 [mm] x (H) 1750 [mm]	

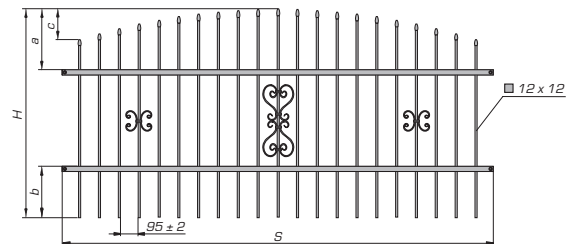

$H \geq 1100$: $a=350$, $b=300$, $c=175$, $H_{min}=900$ $900 \leq H < 1100$: $a=350$, $b=200$, $c=175$, $H_{min}=900$

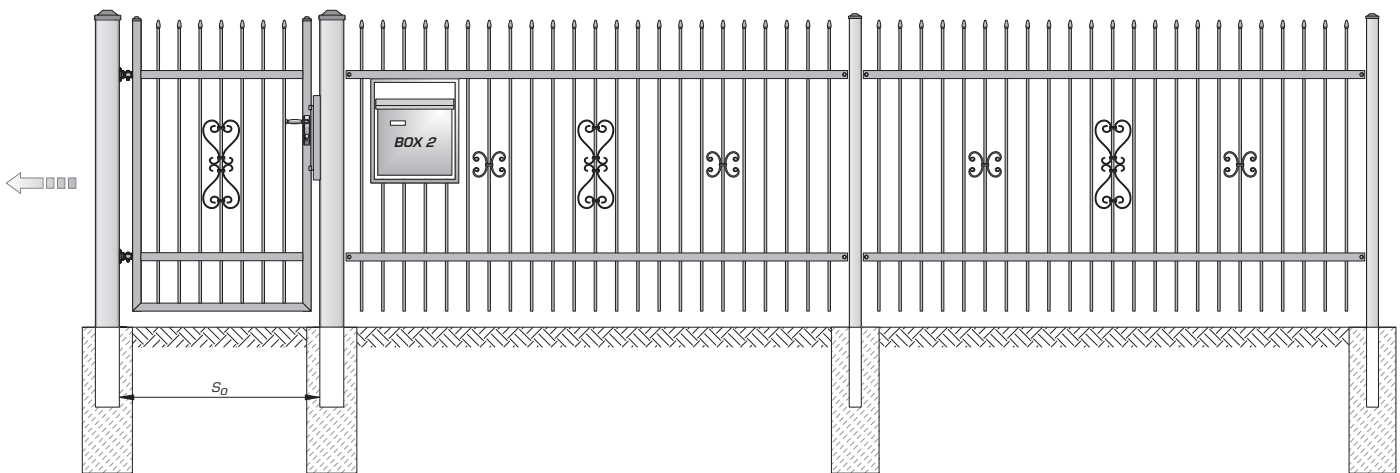
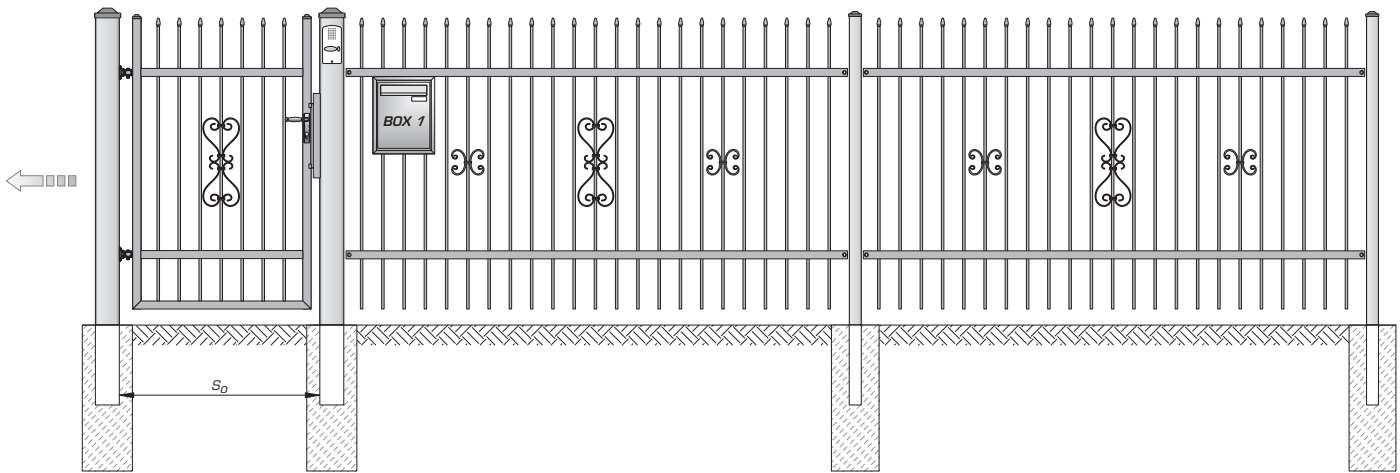

AW.10.24/Wk

(S) 2500 [mm] x (H) 900 [mm] - 39 kg	(S) 3000 [mm] x (H) 1200 [mm] - 55 kg
(S) 2500 [mm] x (H) 1200 [mm] - 46 kg	(S) 3000 [mm] x (H) 1450 [mm] - 64 kg
(S) 2500 [mm] x (H) 1450 [mm] - 53 kg	
max: (S) 3000 [mm] x (H) 1750 [mm]	

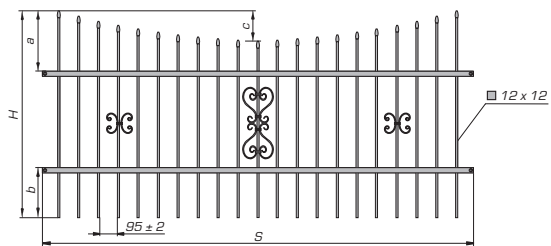

$H \geq 1100$: a=350, b=300, c=175, $H_{min}=900$ $900 \leq H < 1100$: a=350, b=200, c=175, $H_{min}=900$

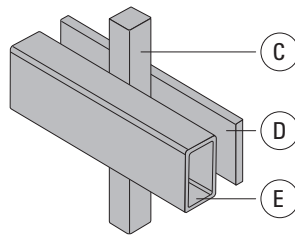

- U2
- C 12x12
- D 30x5
- E 30x18

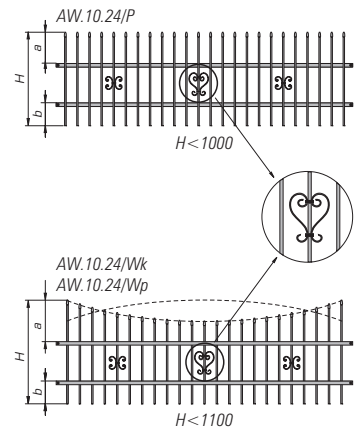



System Classic
AW.10.01





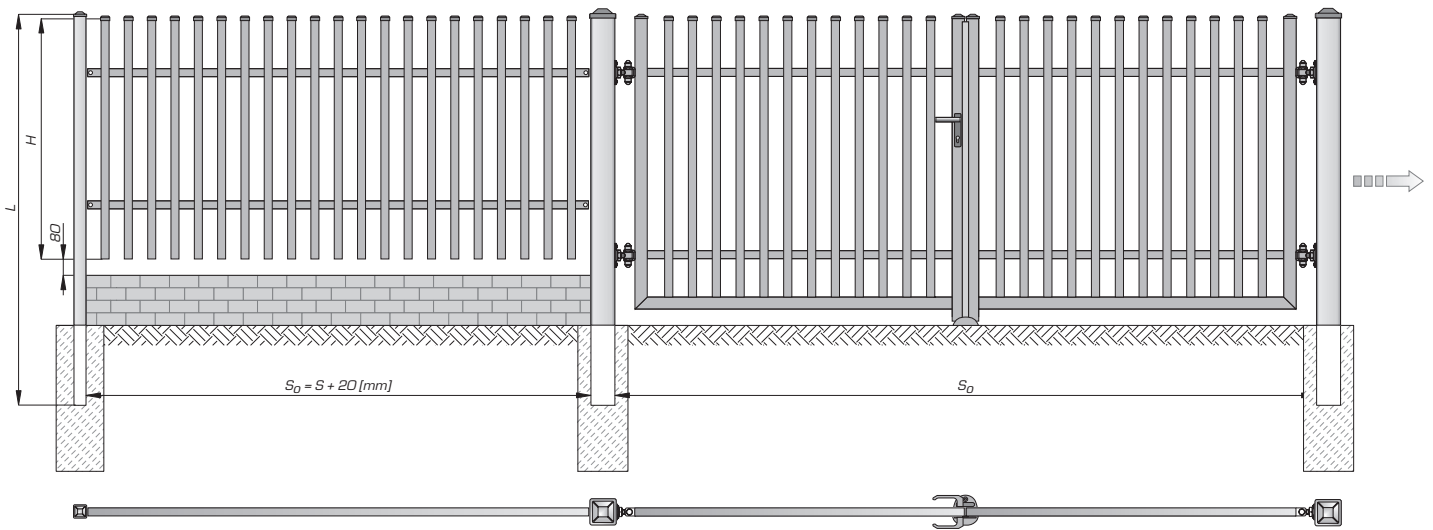
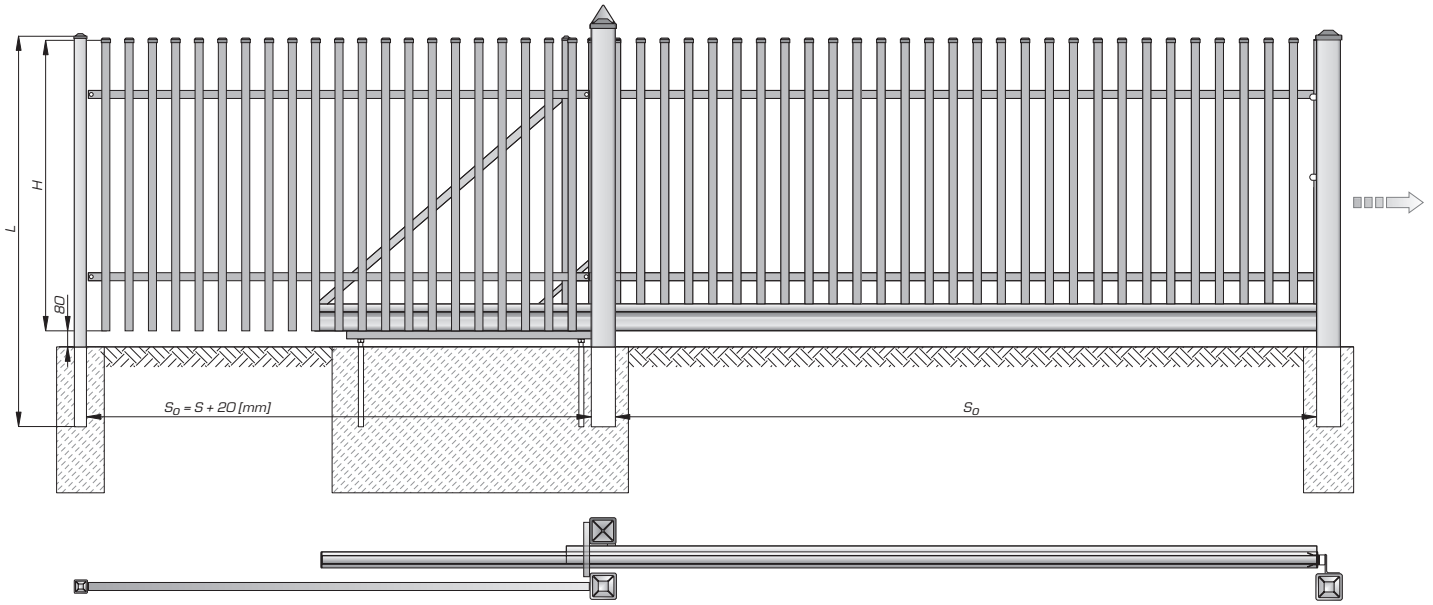

AW.10.01/P

(S) 2500 [mm] x (H) 900 [mm] - 30 kg	(S) 3000 [mm] x (H) 1200 [mm] - 42 kg
(S) 2500 [mm] x (H) 1200 [mm] - 35 kg	(S) 3000 [mm] x (H) 1450 [mm] - 48 kg
(S) 2500 [mm] x (H) 1450 [mm] - 40 kg	
max: (S) 3000 [mm] x (H) 1950 [mm]	

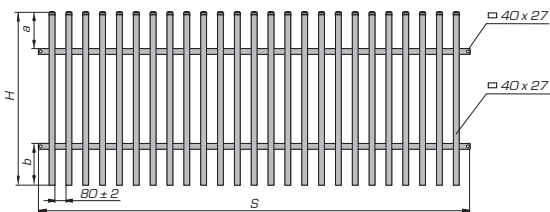

$H \geq 1000$: $a=250$, $b=300$, $H_{min}=800$ $800 \leq H < 1000$: $a=250$, $b=200$, $H_{min}=800$

AW.10.01/Wp

(S) 2500 [mm] x (H) 900 [mm] - 28 kg	(S) 3000 [mm] x (H) 1200 [mm] - 40 kg
(S) 2500 [mm] x (H) 1200 [mm] - 33 kg	(S) 3000 [mm] x (H) 1450 [mm] - 46 kg
(S) 2500 [mm] x (H) 1450 [mm] - 38 kg	
max: (S) 3000 [mm] x (H) 1950 [mm]	

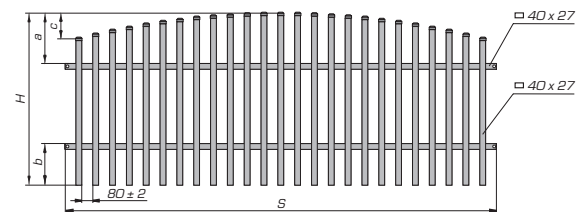

$H \geq 1100$: $a=350$, $b=300$, $c=175$, $H_{min}=900$ $900 \leq H < 1100$: $a=350$, $b=200$, $c=175$, $H_{min}=900$

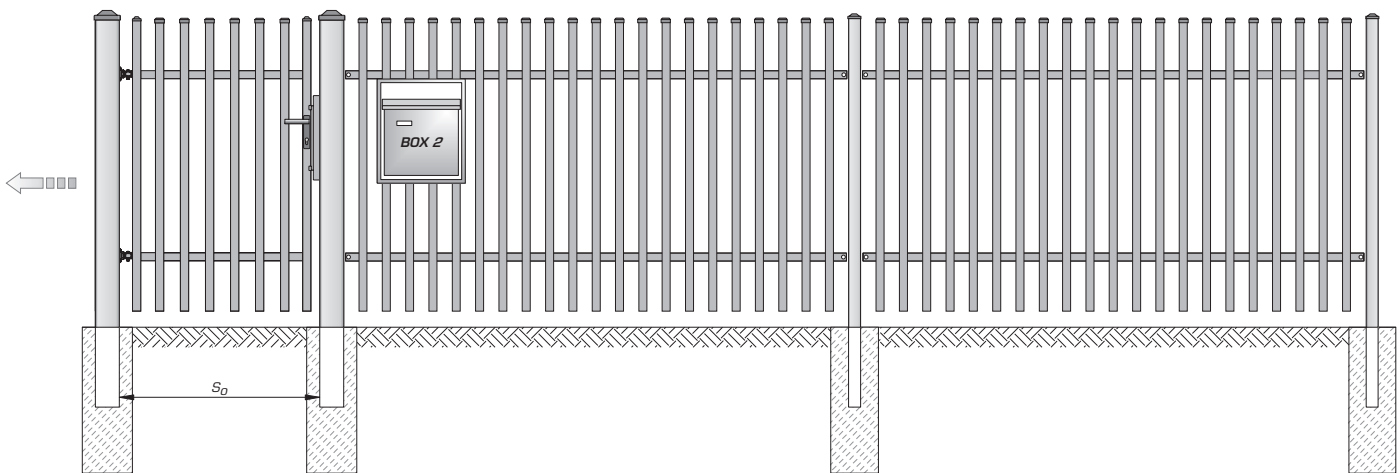
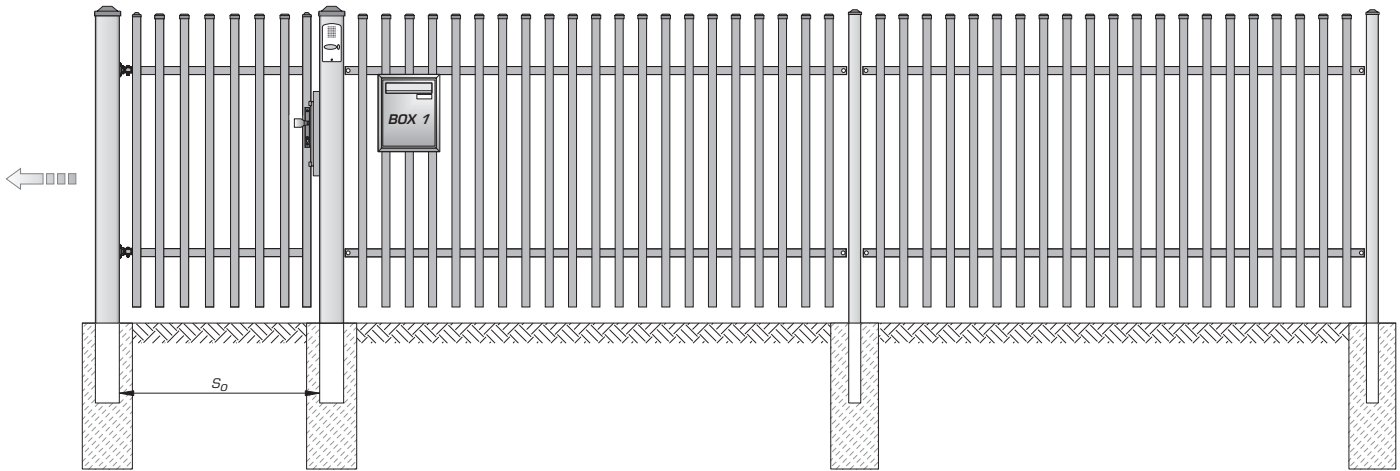

AW.10.01/Wk

(S) 2500 [mm] x (H) 900 [mm] - 28 kg	(S) 3000 [mm] x (H) 1200 [mm] - 40 kg
(S) 2500 [mm] x (H) 1200 [mm] - 33 kg	(S) 3000 [mm] x (H) 1450 [mm] - 46 kg
(S) 2500 [mm] x (H) 1450 [mm] - 38 kg	
max: (S) 3000 [mm] x (H) 1950 [mm]	

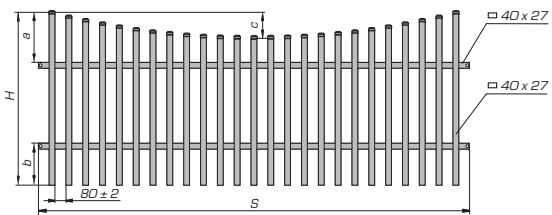

$H \geq 1100$: $a=350, b=300, c=175, H_{min}=900$ $900 \leq H < 1100$: $a=350, b=200, c=175, H_{min}=900$

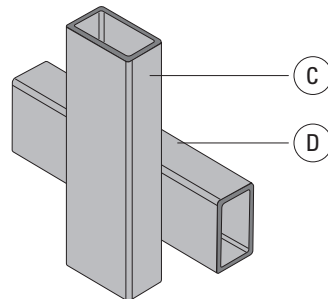

U1 C 40x27 D 40x27



System Classic
AW.10.02

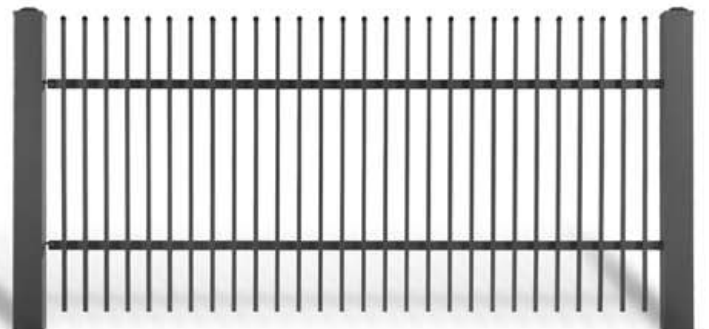

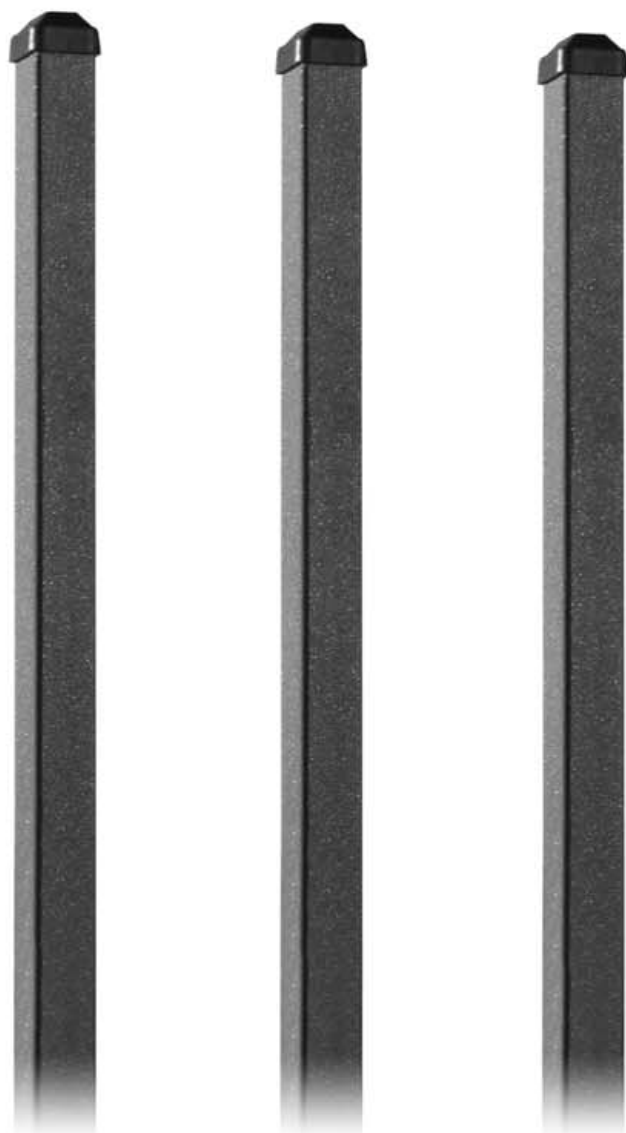

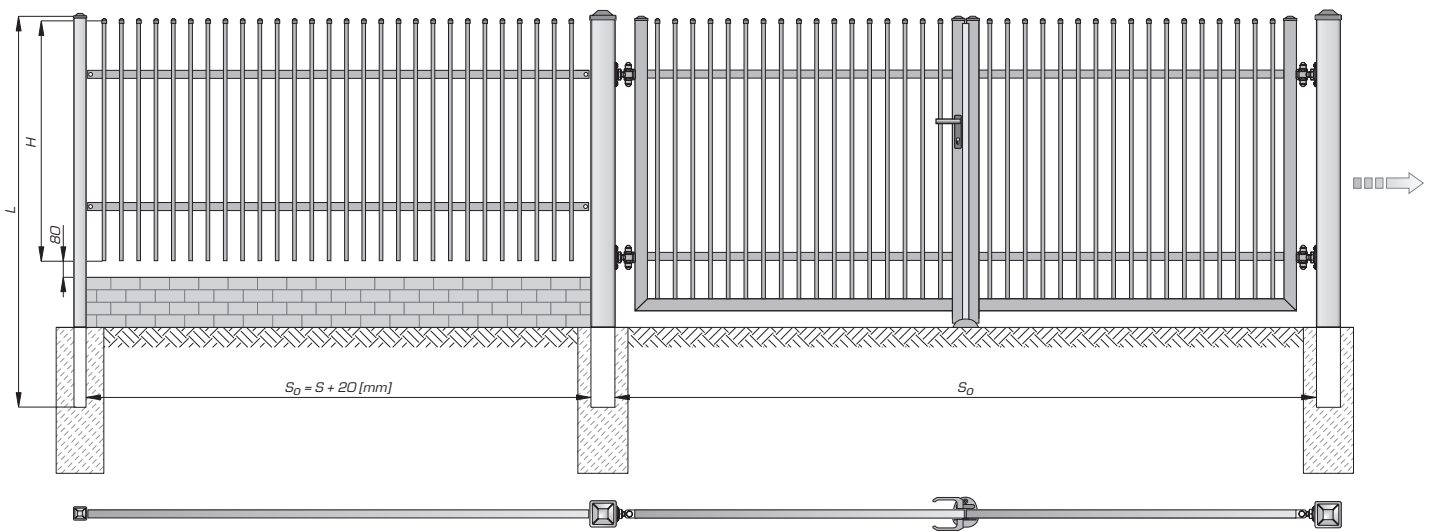
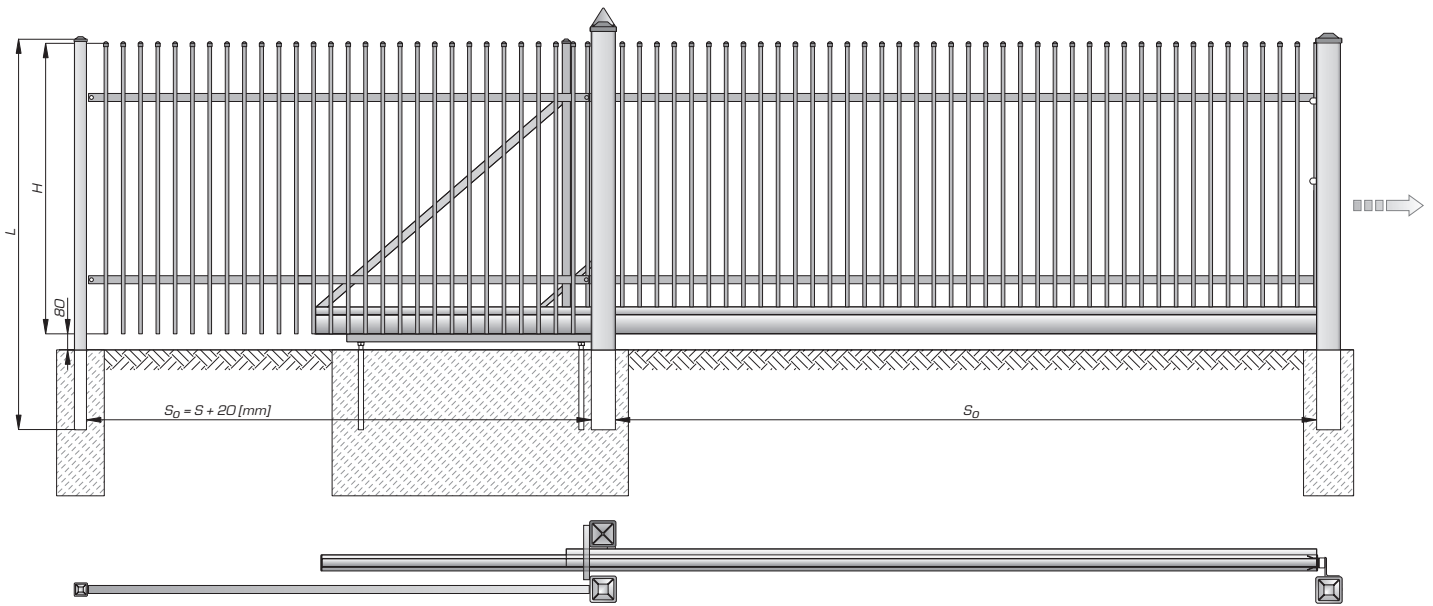

AW.10.02/P

(S) 2500 [mm] x (H) 900 [mm] - 27 kg	(S) 3000 [mm] x (H) 1200 [mm] - 40 kg
(S) 2500 [mm] x (H) 1200 [mm] - 33 kg	(S) 3000 [mm] x (H) 1450 [mm] - 47 kg
(S) 2500 [mm] x (H) 1450 [mm] - 39 kg	
max: (S) 3000 [mm] x (H) 1750 [mm]	

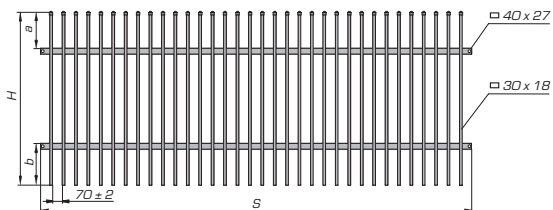

$H \geq 1000$: a=250, b=300, $H_{min}=800$	$800 \leq H < 1000$: a=250, b=200, $H_{min}=800$
---	---

AW.10.02/Wp

(S) 2500 [mm] x (H) 900 [mm] - 25 kg	(S) 3000 [mm] x (H) 1200 [mm] - 38 kg
(S) 2500 [mm] x (H) 1200 [mm] - 31 kg	(S) 3000 [mm] x (H) 1450 [mm] - 45 kg
(S) 2500 [mm] x (H) 1450 [mm] - 37 kg	
max: (S) 3000 [mm] x (H) 1750 [mm]	

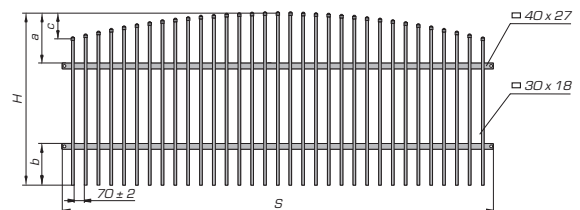

$H \geq 1100$: a=350, b=300, c=175, $H_{min}=900$	$900 \leq H < 1100$: a=350, b=200, c=175, $H_{min}=900$
--	--

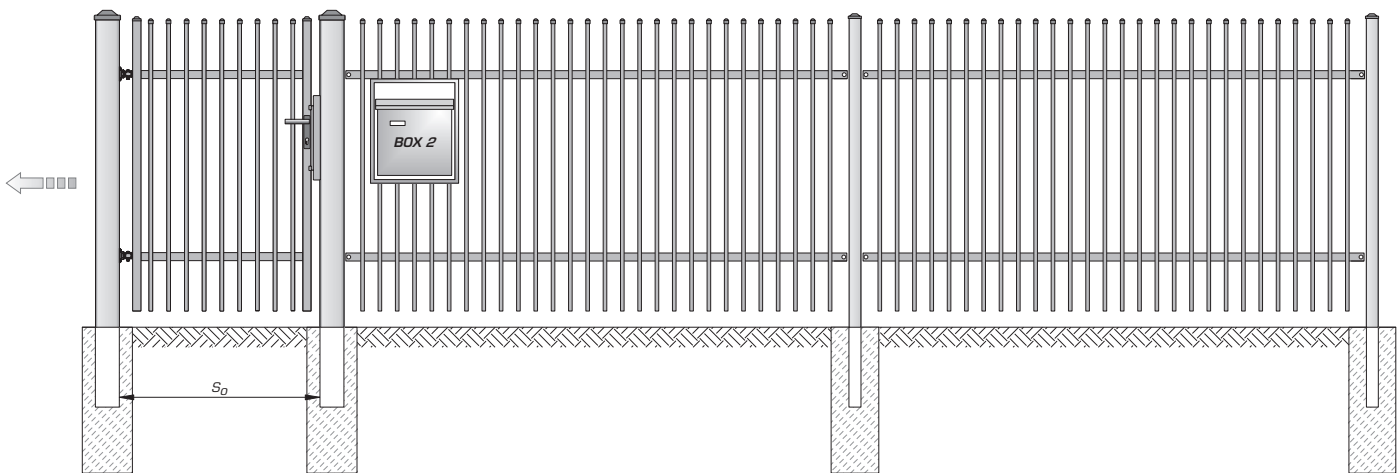
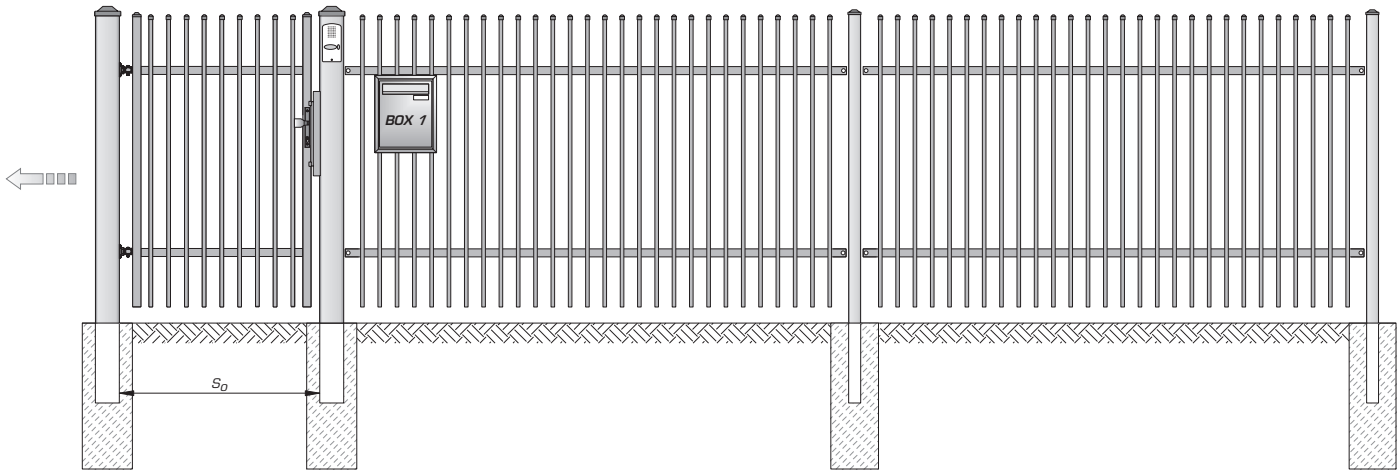

AW.10.02/Wk

(S) 2500 [mm] x (H) 900 [mm] - 25 kg	(S) 3000 [mm] x (H) 1200 [mm] - 38 kg
(S) 2500 [mm] x (H) 1200 [mm] - 31 kg	(S) 3000 [mm] x (H) 1450 [mm] - 45 kg
(S) 2500 [mm] x (H) 1450 [mm] - 37 kg	
max: (S) 3000 [mm] x (H) 1750 [mm]	

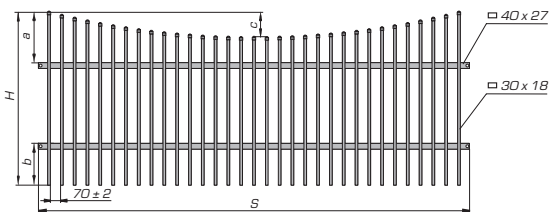

$H \geq 1100$: $a=350, b=300, c=175, H_{min}=900$ $900 \leq H < 1100$: $a=350, b=200, c=175, H_{min}=900$

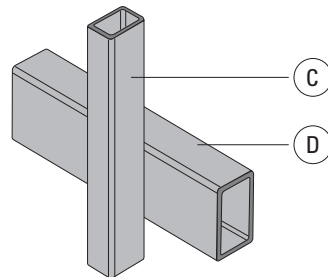

U1 C 30x18 D 40x27



System Classic
AW.10.03

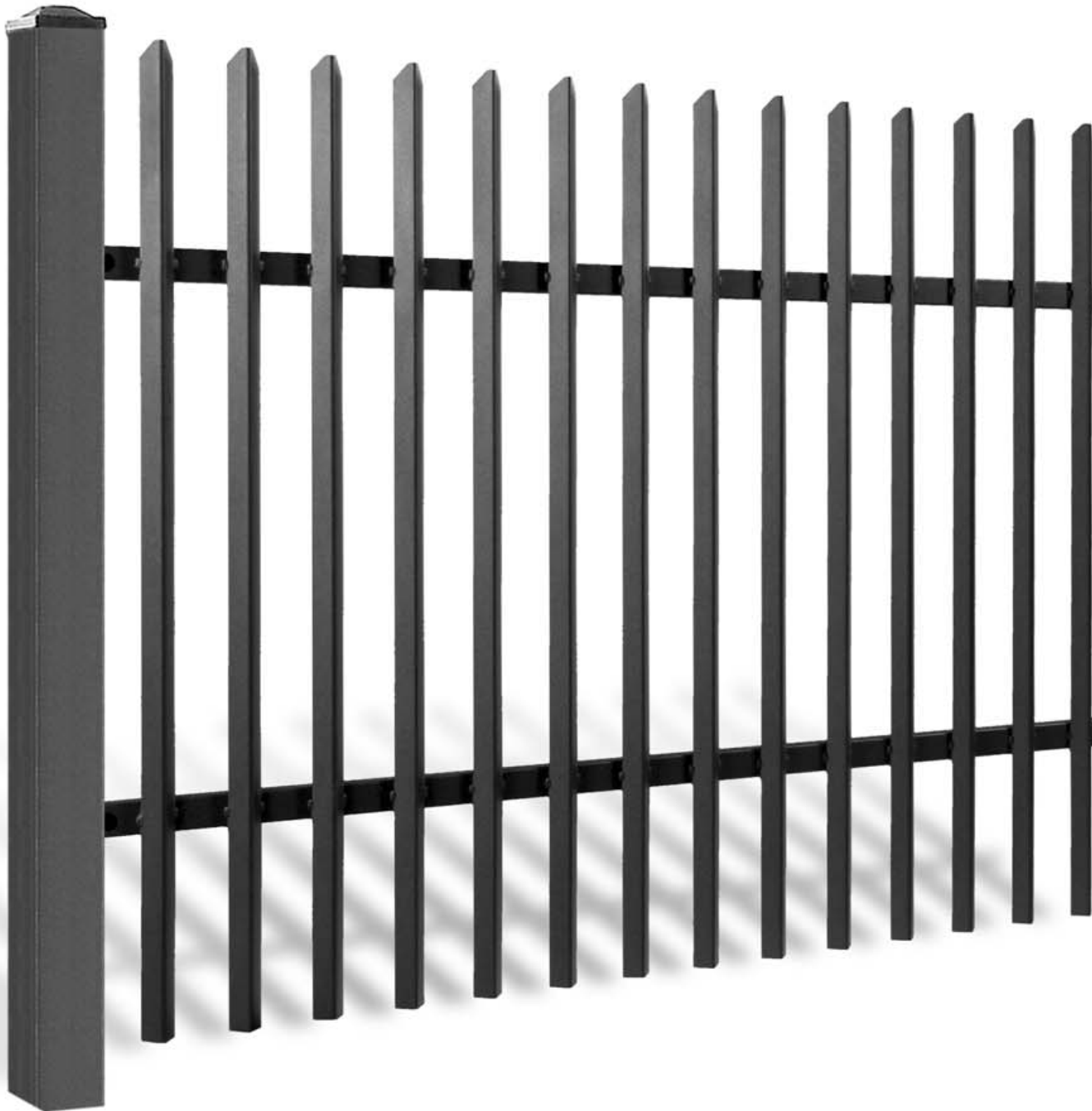

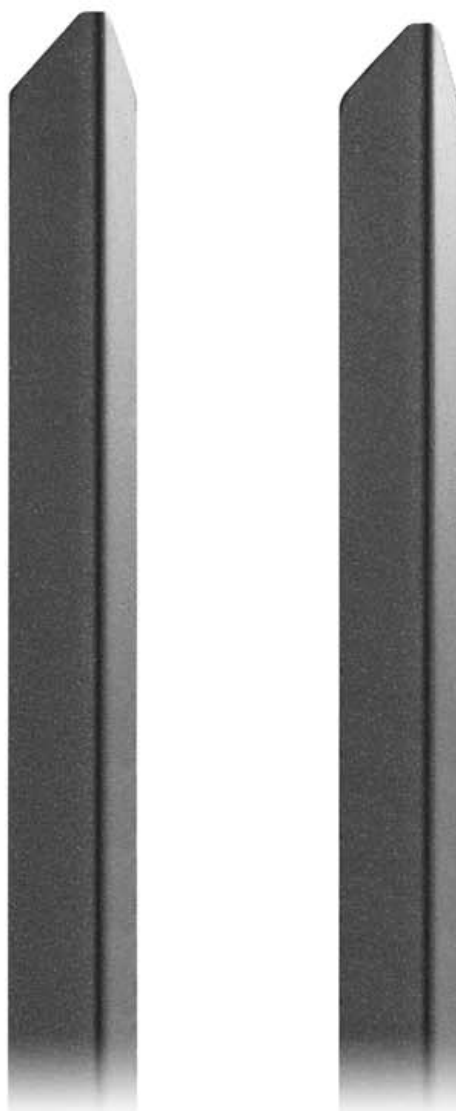

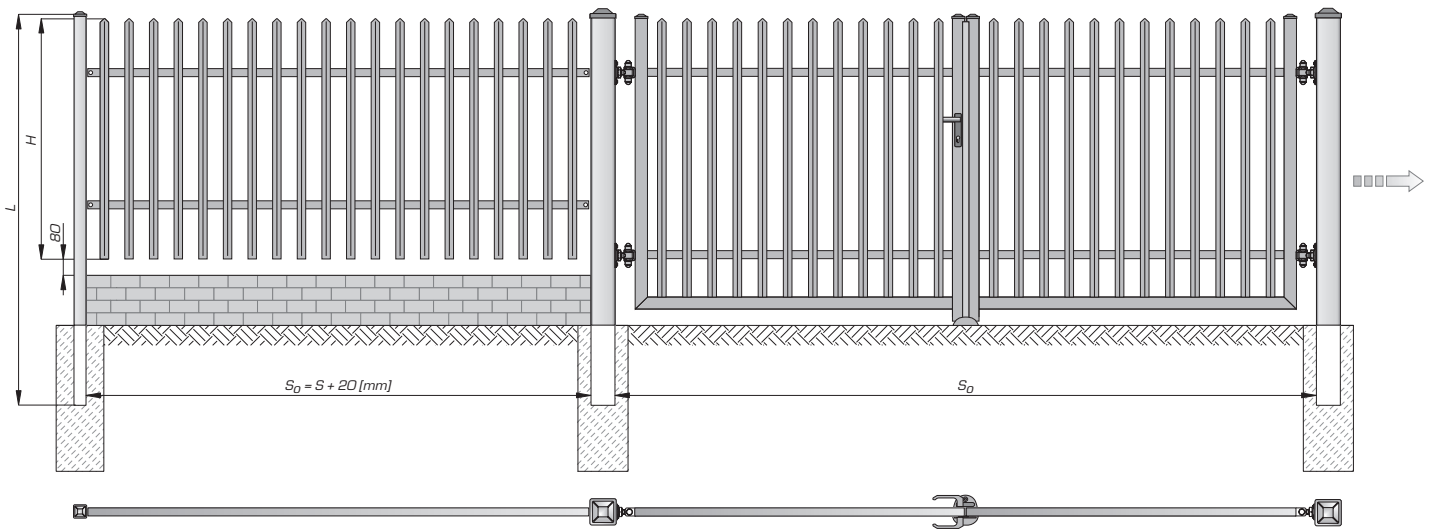
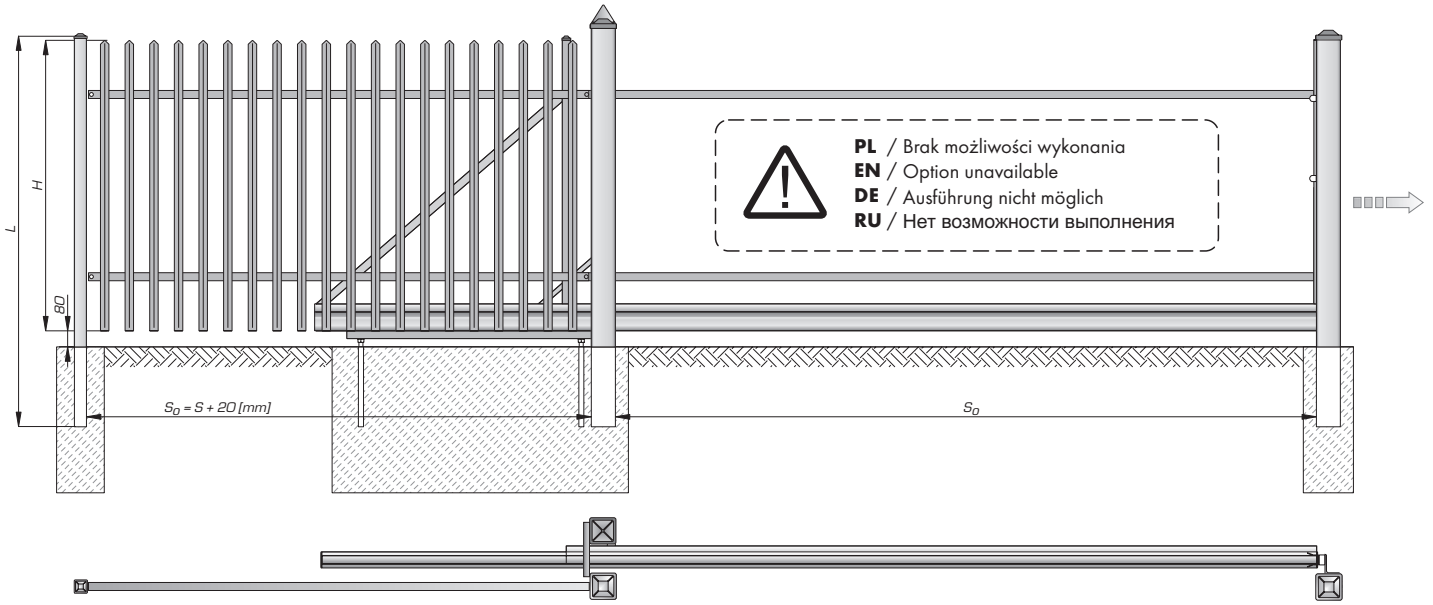

AW.10.03/P

(S) 2500 [mm] x (H) 900 [mm] - 28 kg	(S) 3000 [mm] x (H) 1200 [mm] - 40 kg
(S) 2500 [mm] x (H) 1200 [mm] - 33 kg	(S) 3000 [mm] x (H) 1450 [mm] - 45 kg
(S) 2500 [mm] x (H) 1450 [mm] - 38 kg	
max: (S) 3000 [mm] x (H) 1950 [mm]	

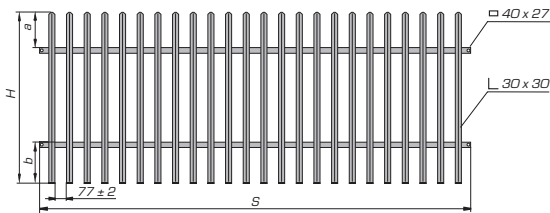

$H \geq 1000$: $a=250$, $b=300$, $H_{min}=800$ $800 \leq H < 1000$: $a=250$, $b=200$, $H_{min}=800$

AW.10.03/Wp

(S) 2500 [mm] x (H) 900 [mm] - 27 kg	(S) 3000 [mm] x (H) 1200 [mm] - 39 kg
(S) 2500 [mm] x (H) 1200 [mm] - 32 kg	(S) 3000 [mm] x (H) 1450 [mm] - 44 kg
(S) 2500 [mm] x (H) 1450 [mm] - 37 kg	
max: (S) 3000 [mm] x (H) 1950 [mm]	

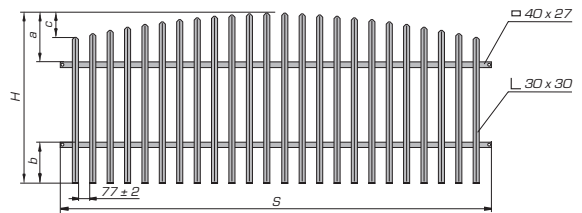

$H \geq 1100$: $a=350$, $b=300$, $c=175$, $H_{min}=900$ $900 \leq H < 1100$: $a=350$, $b=200$, $c=175$, $H_{min}=900$

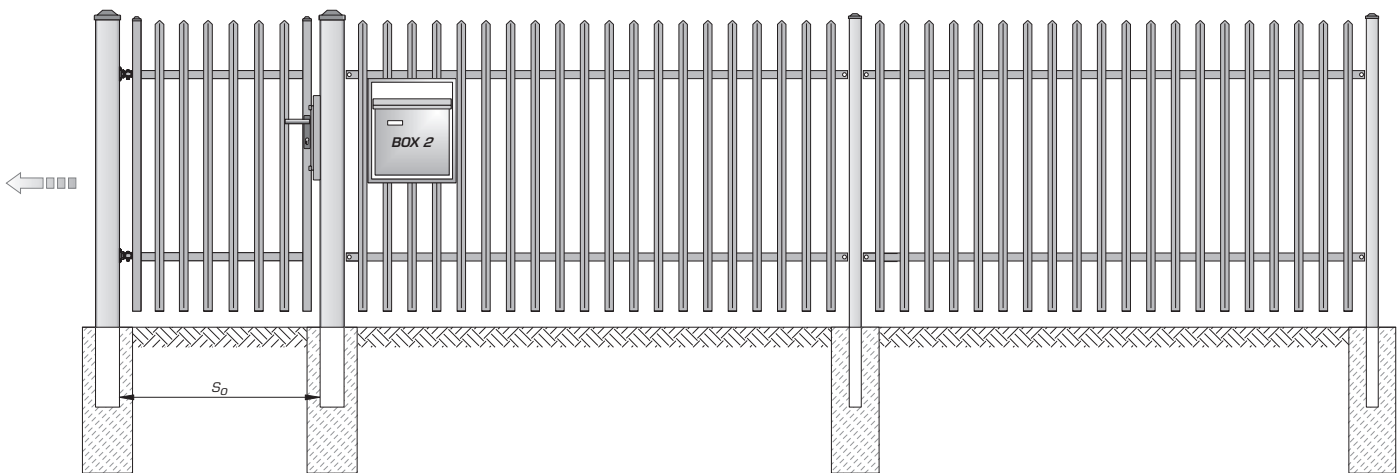
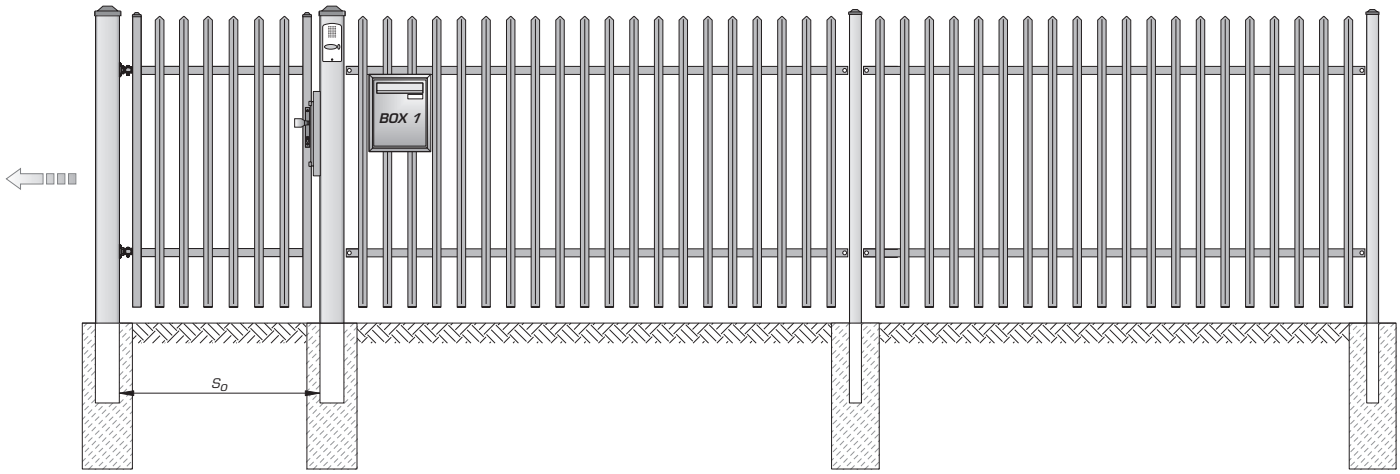

AW.10.03/Wk

(S) 2500 [mm] x (H) 900 [mm] - 27 kg	(S) 3000 [mm] x (H) 1200 [mm] - 39 kg
(S) 2500 [mm] x (H) 1200 [mm] - 32 kg	(S) 3000 [mm] x (H) 1450 [mm] - 44 kg
(S) 2500 [mm] x (H) 1450 [mm] - 37 kg	
max: (S) 3000 [mm] x (H) 1950 [mm]	

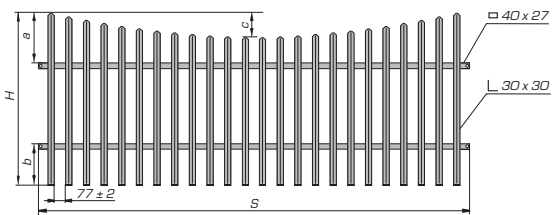

$H \geq 1100$: $a=350, b=300, c=175, H_{min}=900$ $900 \leq H < 1100$: $a=350, b=200, c=175, H_{min}=900$

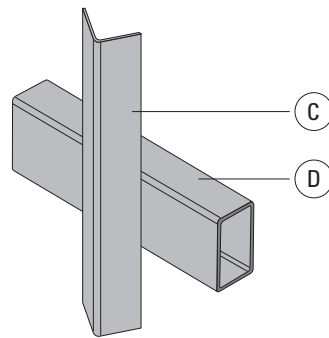

U1 C 30x30 D 40x27



System Classic
AW.10.05

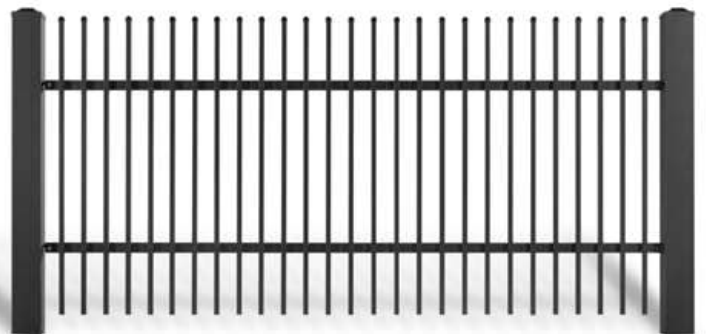
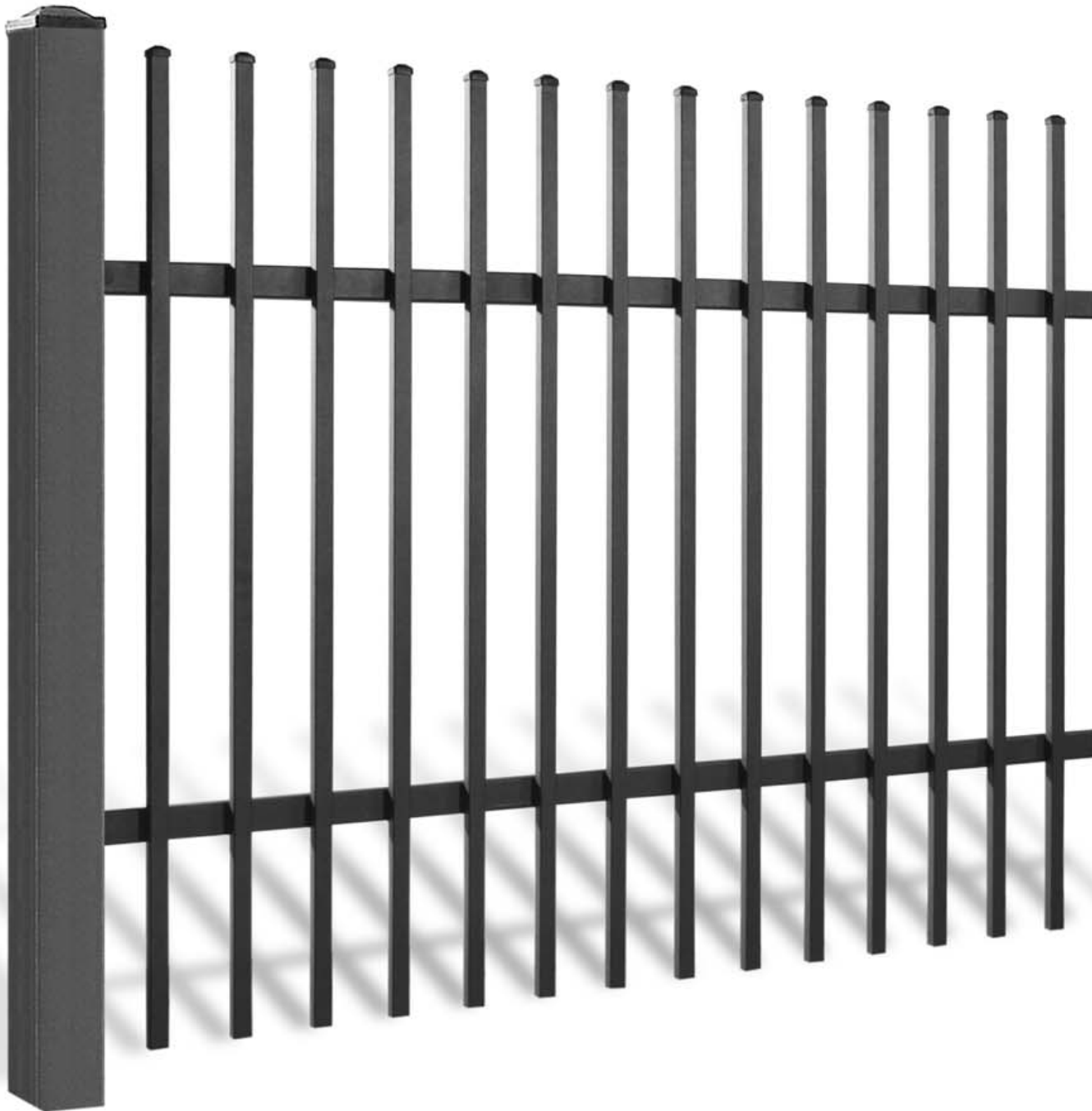

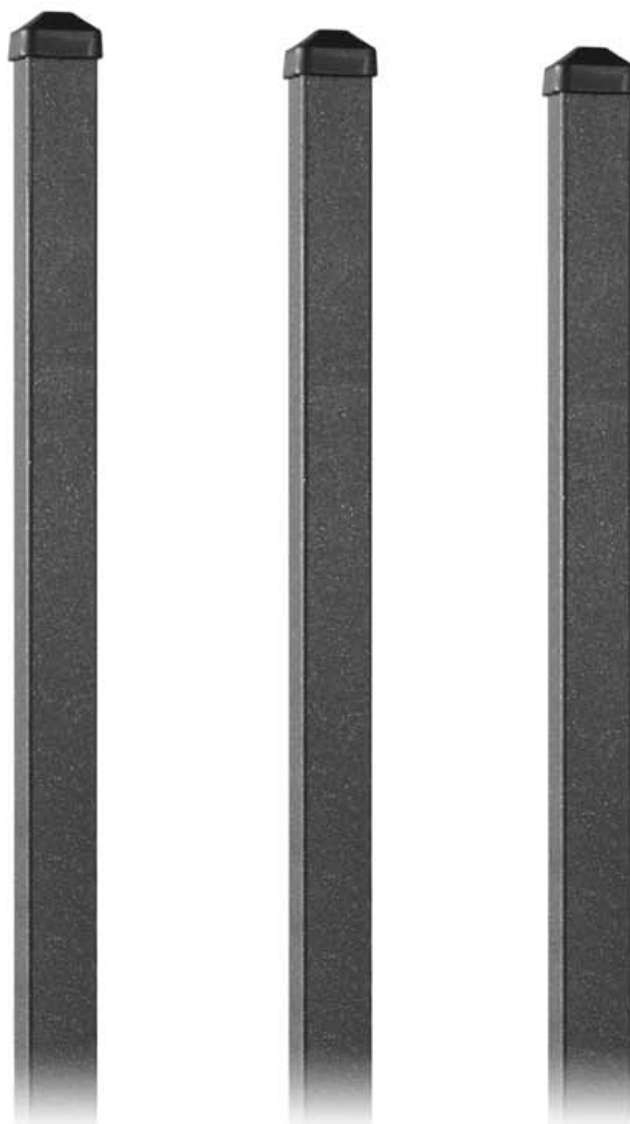

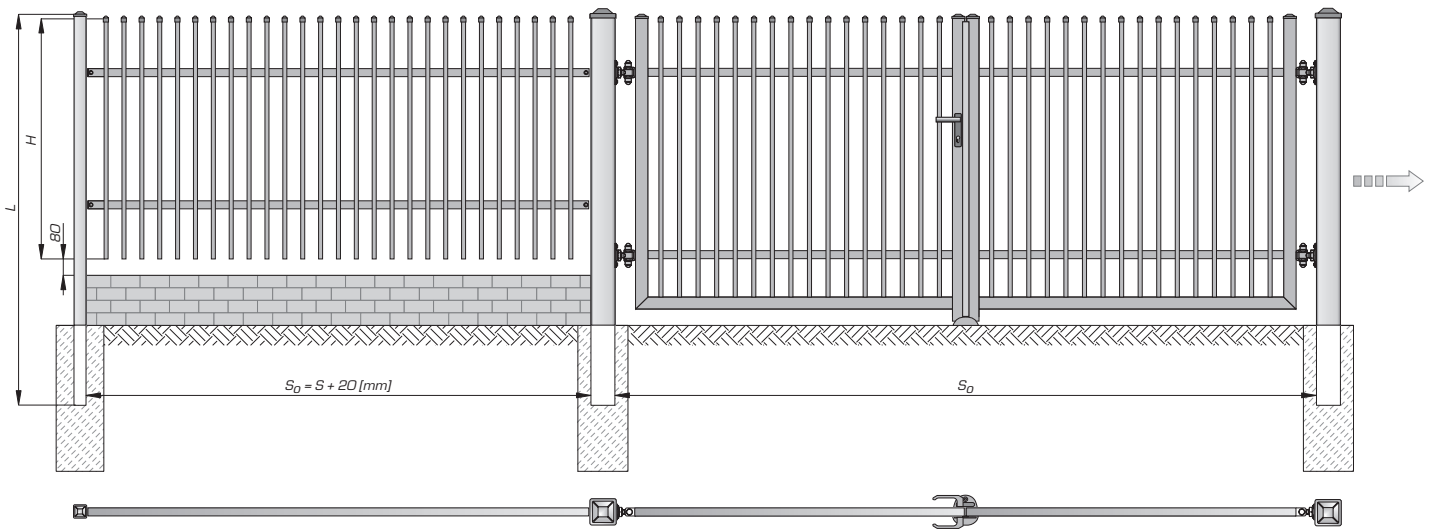
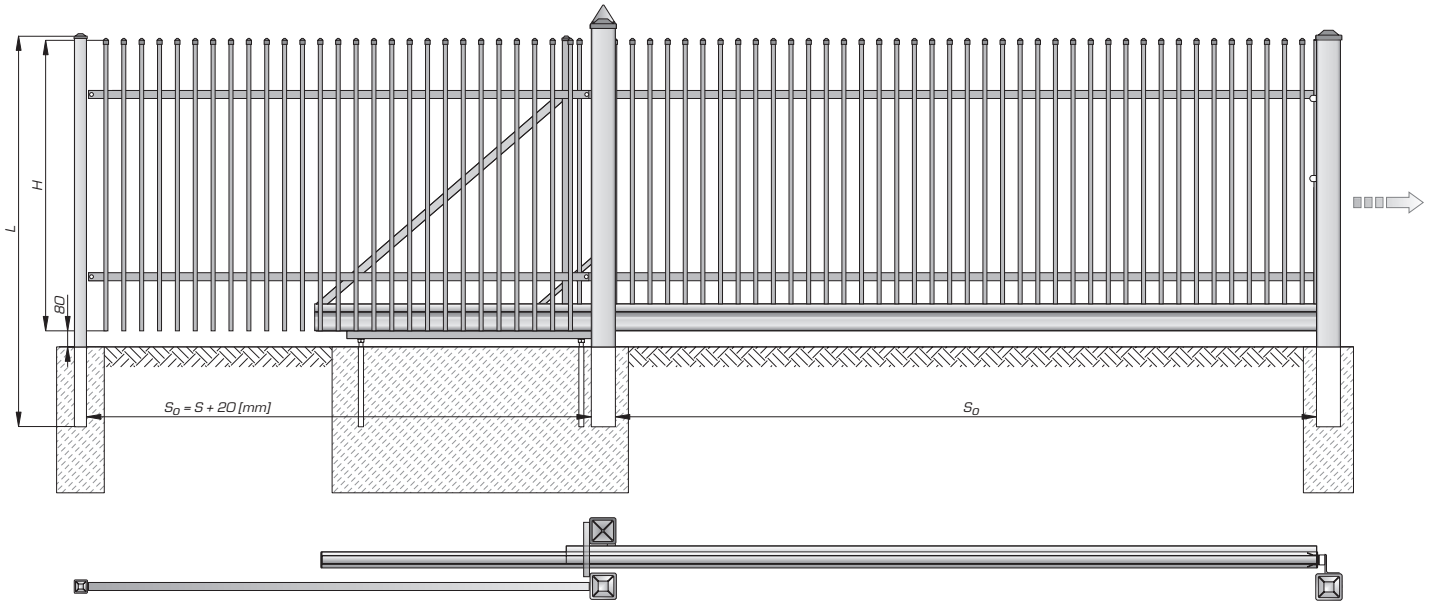

AW.10.05/P

(S) 2500 [mm] x (H) 900 [mm] - 25 kg	(S) 3000 [mm] x (H) 1200 [mm] - 34 kg
(S) 2500 [mm] x (H) 1200 [mm] - 29 kg	(S) 3000 [mm] x (H) 1450 [mm] - 40 kg
(S) 2500 [mm] x (H) 1450 [mm] - 33 kg	
max: (S) 3000 [mm] x (H) 1750 [mm]	

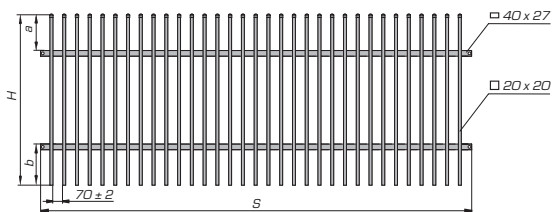

$H \geq 1000$: $a=250$, $b=300$, $H_{min}=800$ $800 \leq H < 1000$: $a=250$, $b=200$, $H_{min}=800$

AW.10.05/Wp

(S) 2500 [mm] x (H) 900 [mm] - 23 kg	(S) 3000 [mm] x (H) 1200 [mm] - 32 kg
(S) 2500 [mm] x (H) 1200 [mm] - 27 kg	(S) 3000 [mm] x (H) 1450 [mm] - 38 kg
(S) 2500 [mm] x (H) 1450 [mm] - 31 kg	
max: (S) 3000 [mm] x (H) 1750 [mm]	

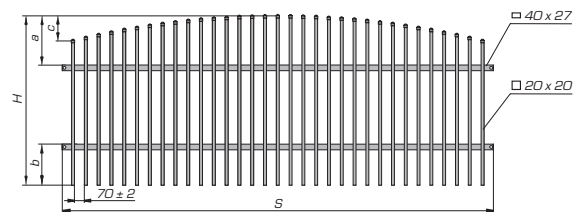

$H \geq 1100$: $a=350$, $b=300$, $c=175$, $H_{min}=900$ $900 \leq H < 1100$: $a=350$, $b=200$, $c=175$, $H_{min}=900$

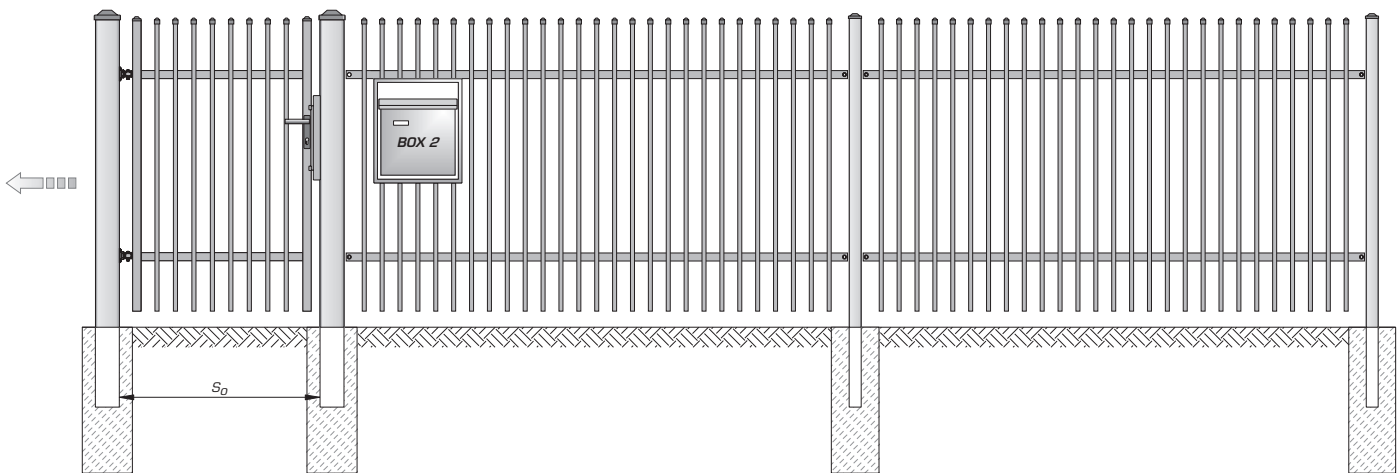
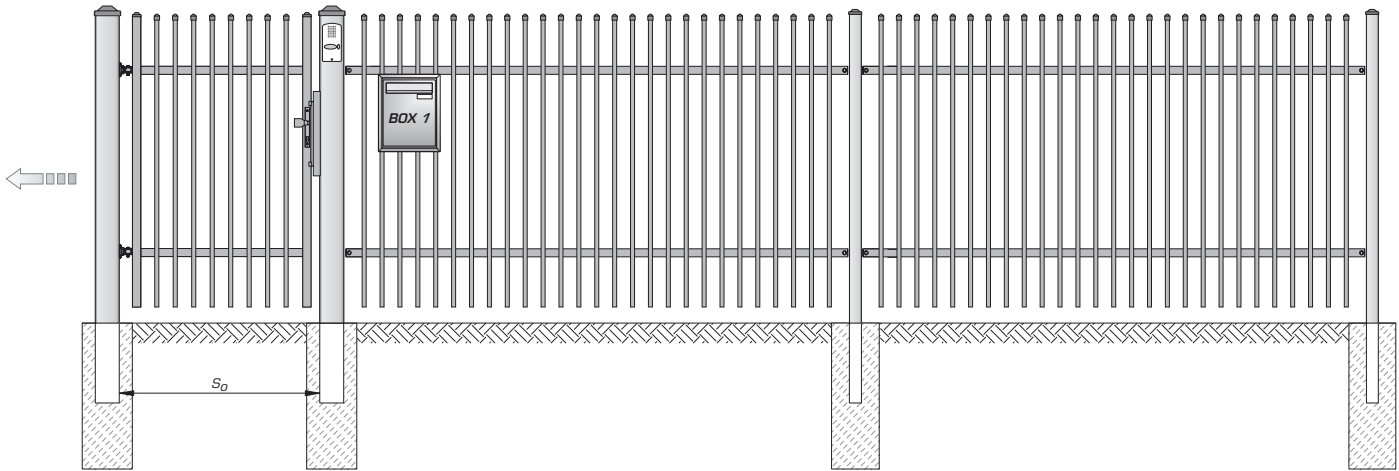

AW.10.05/Wk

(S) 2500 [mm] x (H) 900 [mm] - 23 kg	(S) 3000 [mm] x (H) 1200 [mm] - 32 kg
(S) 2500 [mm] x (H) 1200 [mm] - 27 kg	(S) 3000 [mm] x (H) 1450 [mm] - 38 kg
(S) 2500 [mm] x (H) 1450 [mm] - 31 kg	
max: (S) 3000 [mm] x (H) 1750 [mm]	

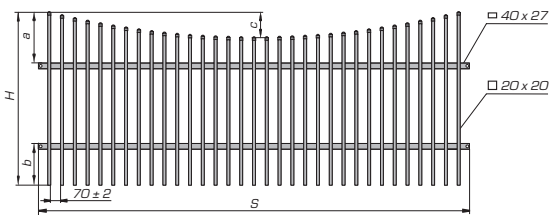

$H \geq 1100$: $a=350, b=300, c=175, H_{min}=900$ $900 \leq H < 1100$: $a=350, b=200, c=175, H_{min}=900$

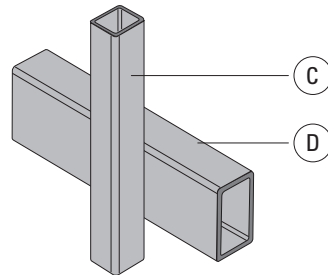

U1 C 20x20 D 40x27



System Classic
AW.10.06

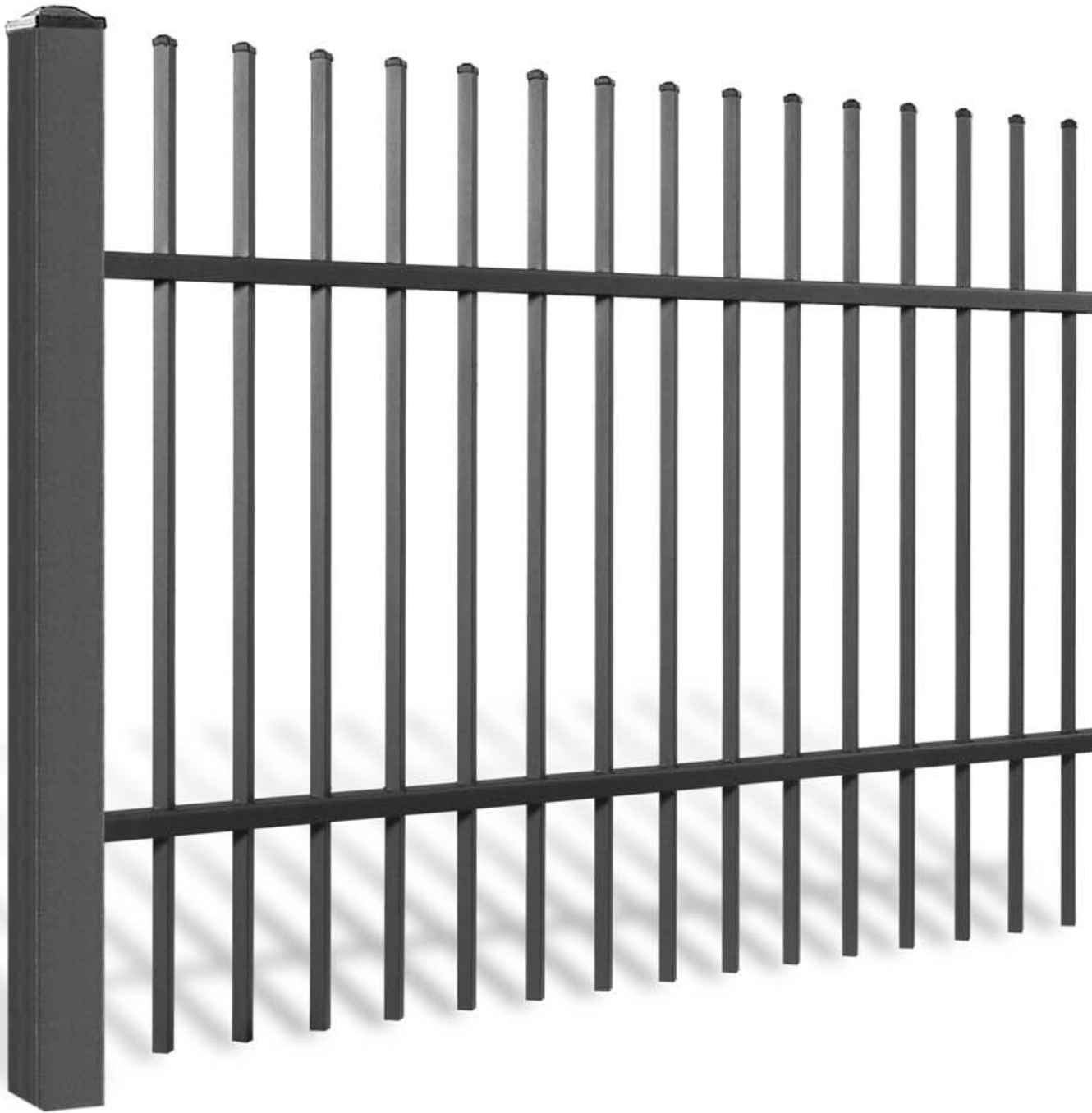

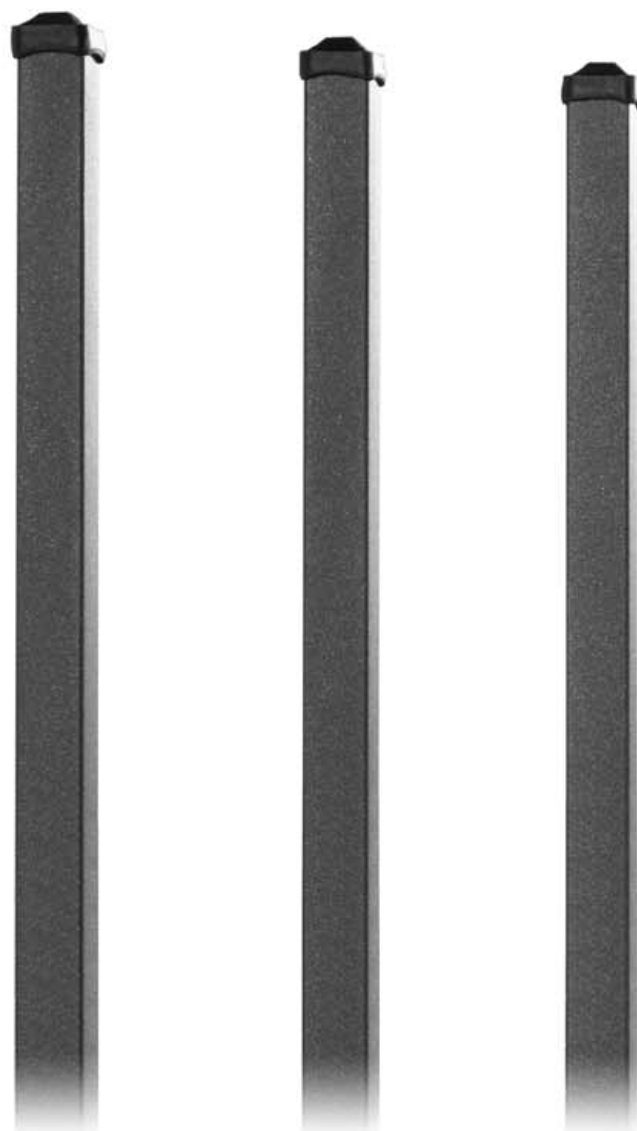

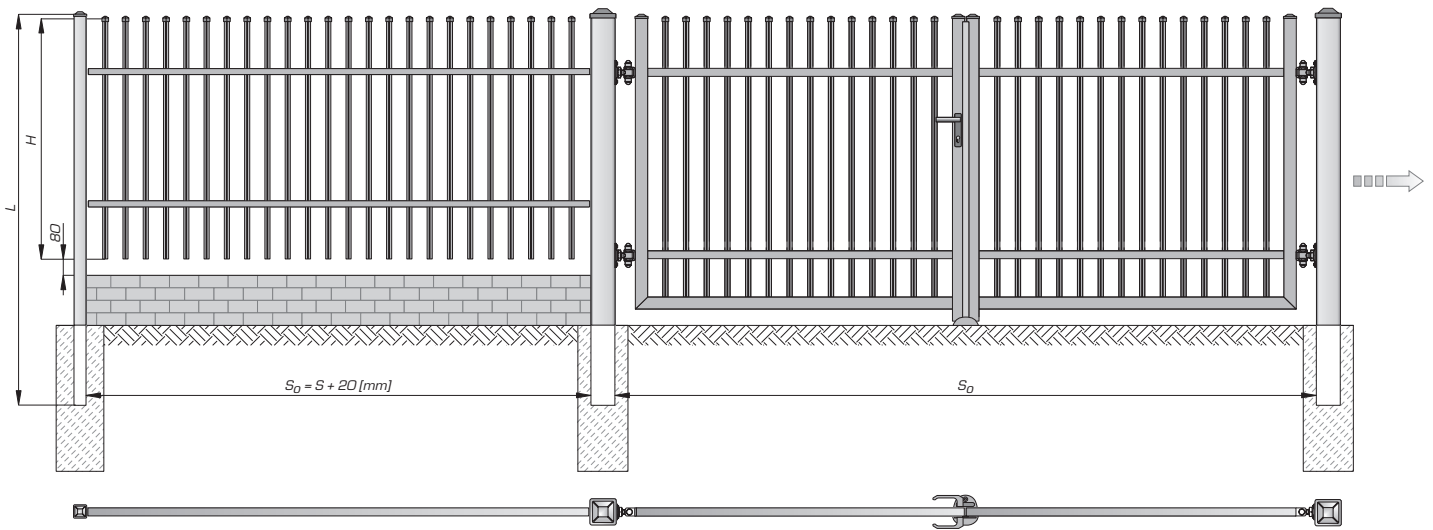
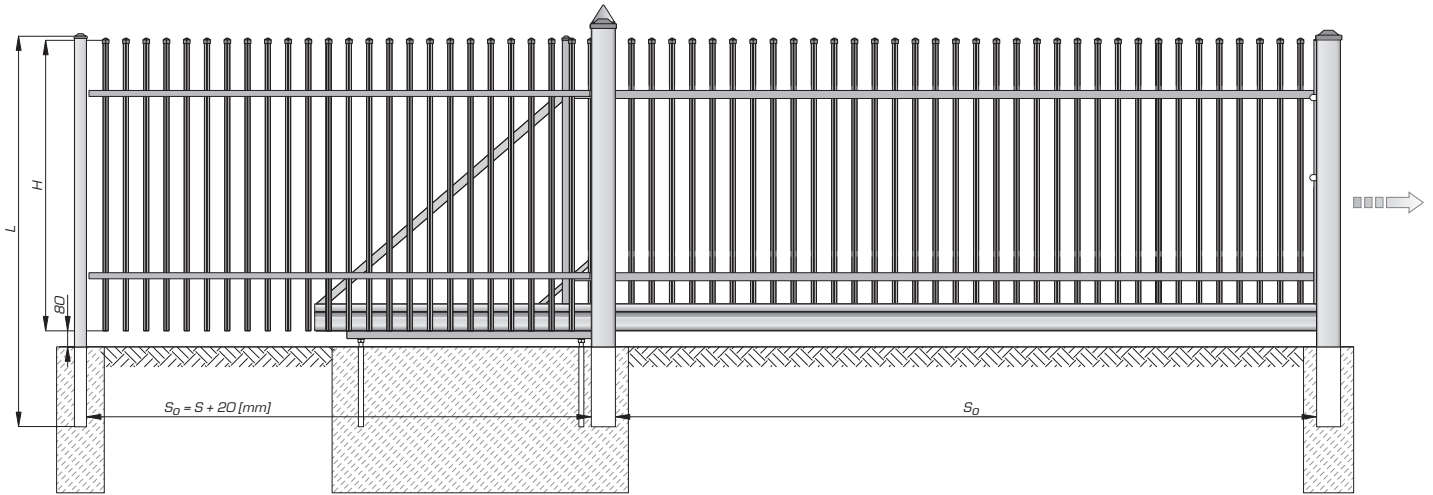

AW.10.06/P

(S) 2500 [mm] x (H) 900 [mm] - 24 kg	(S) 3000 [mm] x (H) 1200 [mm] - 31 kg
(S) 2500 [mm] x (H) 1200 [mm] - 27 kg	(S) 3000 [mm] x (H) 1450 [mm] - 36 kg
(S) 2500 [mm] x (H) 1450 [mm] - 30 kg	
max: (S) 3000 [mm] x (H) 1950 [mm]	

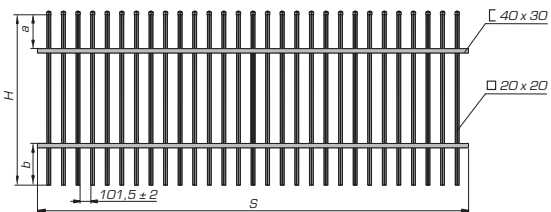

$H \geq 1000$: $a=250$, $b=300$, $H_{min}=800$ $800 \leq H < 1000$: $a=250$, $b=200$, $H_{min}=800$

AW.10.06/Wp

(S) 2500 [mm] x (H) 900 [mm] - 23 kg	(S) 3000 [mm] x (H) 1200 [mm] - 30 kg
(S) 2500 [mm] x (H) 1200 [mm] - 26 kg	(S) 3000 [mm] x (H) 1450 [mm] - 35 kg
(S) 2500 [mm] x (H) 1450 [mm] - 29 kg	
max: (S) 3000 [mm] x (H) 1950 [mm]	

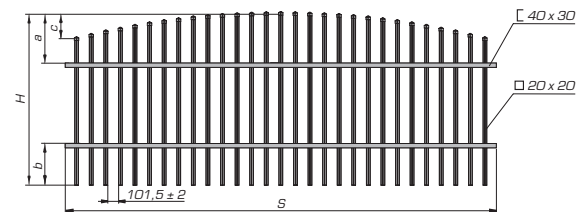

$H \geq 1100$: $a=350$, $b=300$, $c=175$, $H_{min}=900$ $900 \leq H < 1100$: $a=350$, $b=200$, $c=175$, $H_{min}=900$

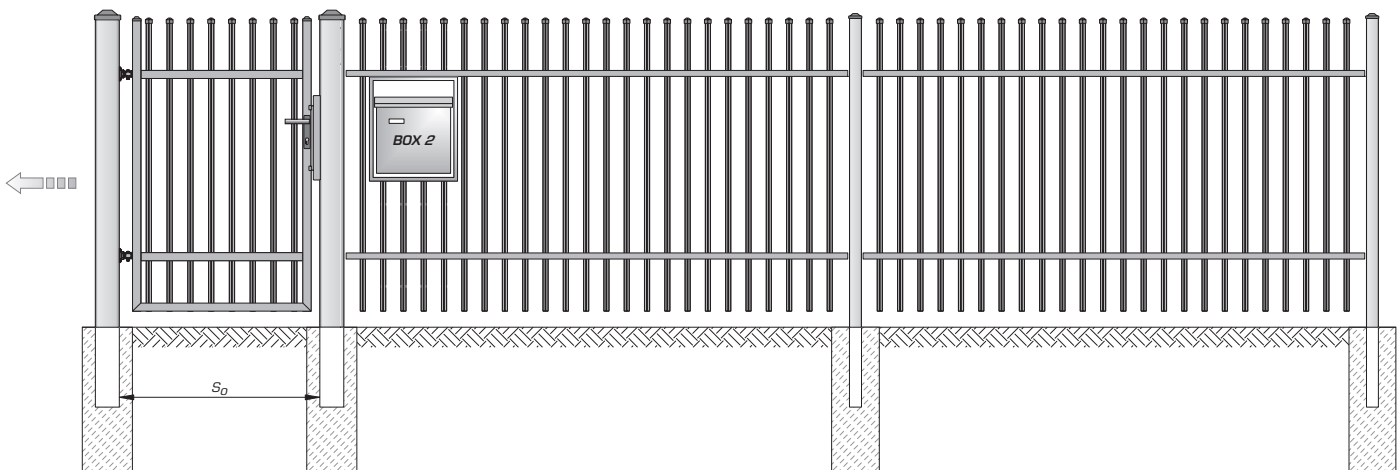
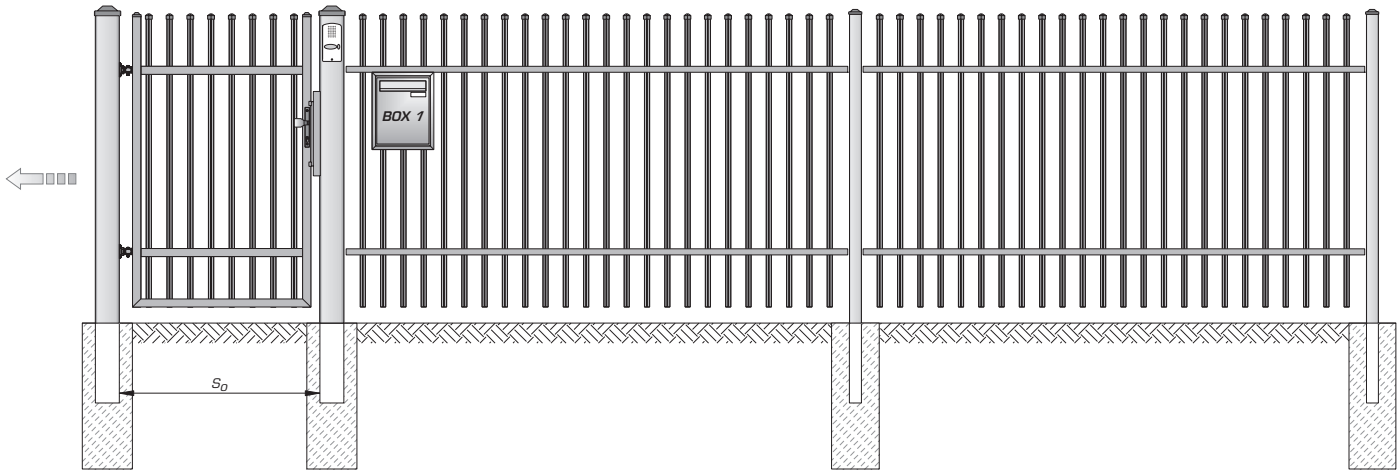

AW.10.06/Wk

(S) 2500 [mm] x (H) 900 [mm] - 23 kg	(S) 3000 [mm] x (H) 1200 [mm] - 30 kg
(S) 2500 [mm] x (H) 1200 [mm] - 26 kg	(S) 3000 [mm] x (H) 1450 [mm] - 35 kg
(S) 2500 [mm] x (H) 1450 [mm] - 29 kg	
max: (S) 3000 [mm] x (H) 1950 [mm]	

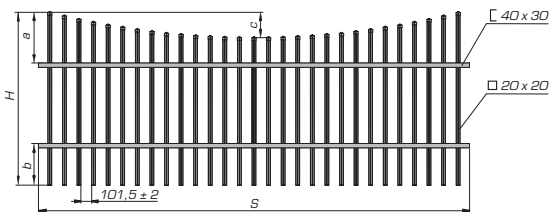

$H \geq 1100$: $a=350$, $b=300$, $c=175$, $H_{min}=900$ $900 \leq H < 1100$: $a=350$, $b=200$, $c=175$, $H_{min}=900$

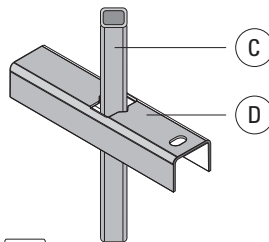

U4

C 20x20

D 40x30

AW.10.06 EKO

- PL / Segment, Brama przesuwna P-55, Furka, Brama dwuskrzydłowa
- EN / Segment, Sliding gate P-55, Wicket, Double-leaf gate
- DE / Zaunfeld, Schiebtor P-55, Pforte, Zweiflügeltor
- RU / Секция, Сдвижные ворота P-55, Калитка, Распашные ворота

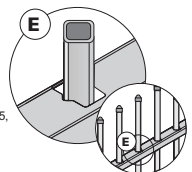

AW.10.06

- PL / Brama przesuwna, Furka, Brama dwuskrzydłowa
- EN / Sliding gate, Wicket, Double-leaf gate
- DE / Schiebtor, Pforte, Zweiflügeltor
- RU / Сдвижные ворота, Калитка, Распашные ворота

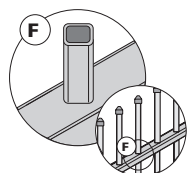



System Classic
AW.10.16

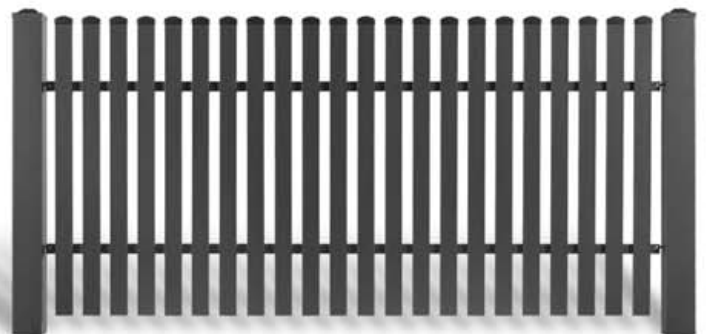
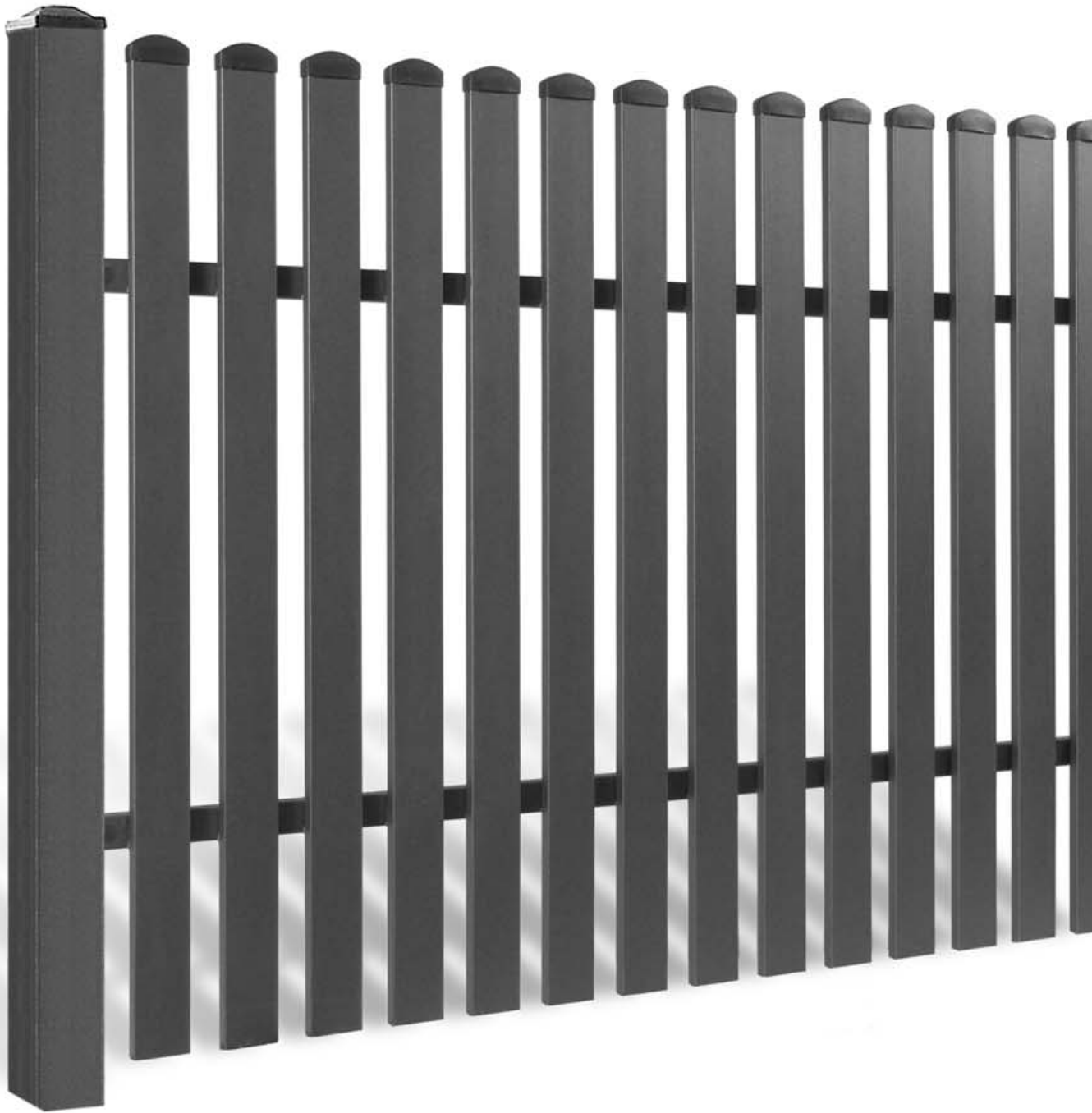

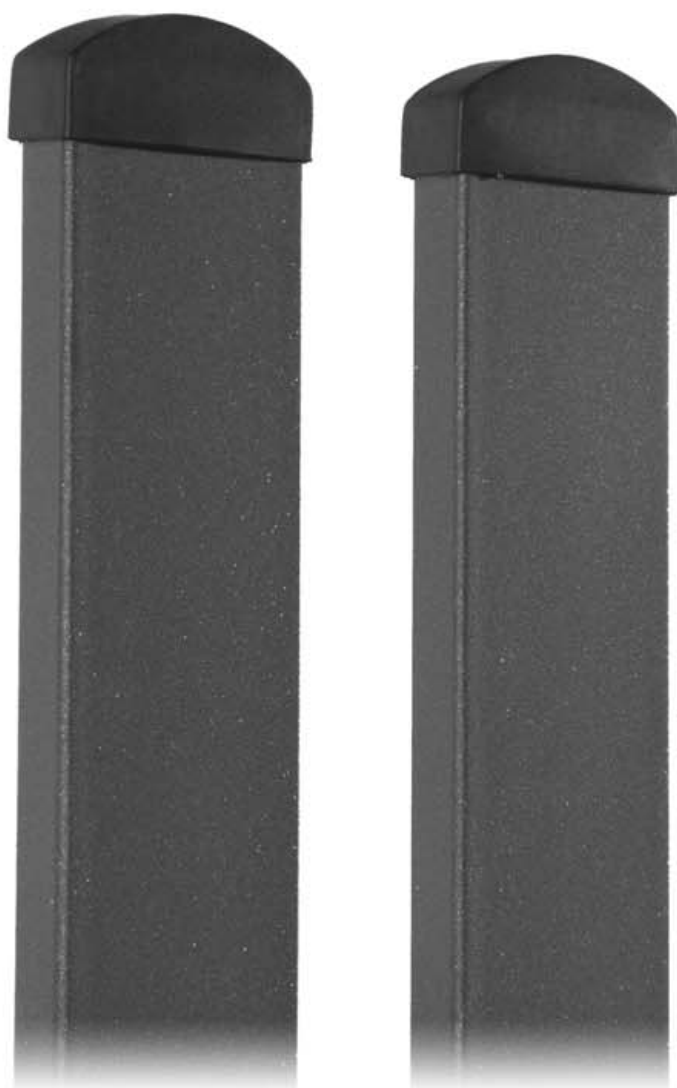

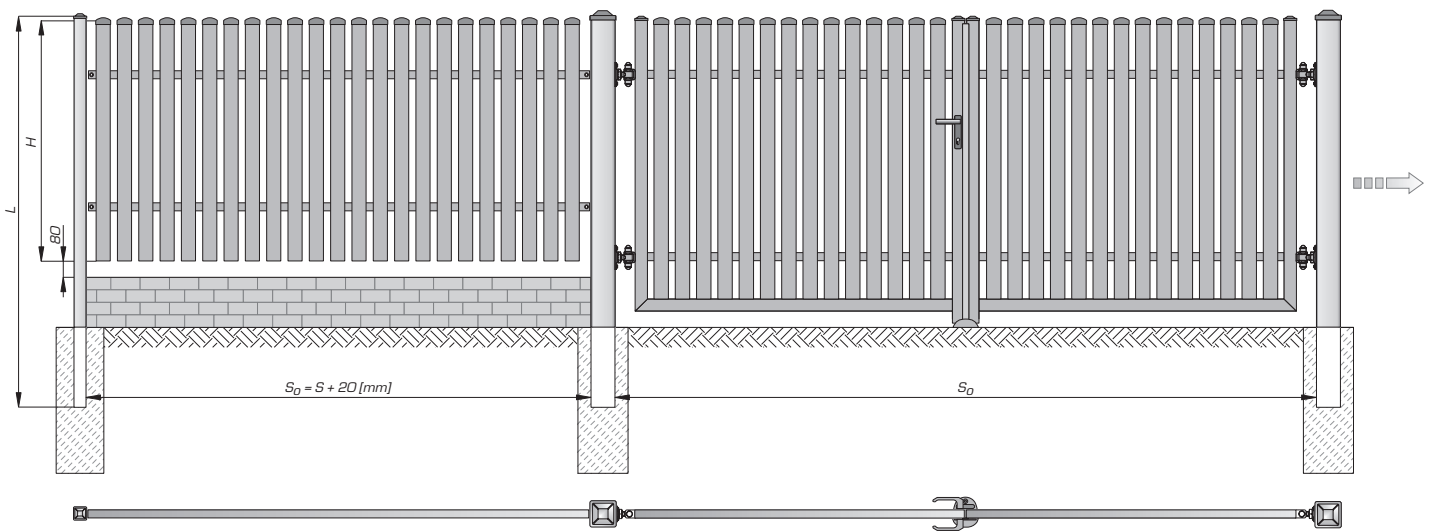
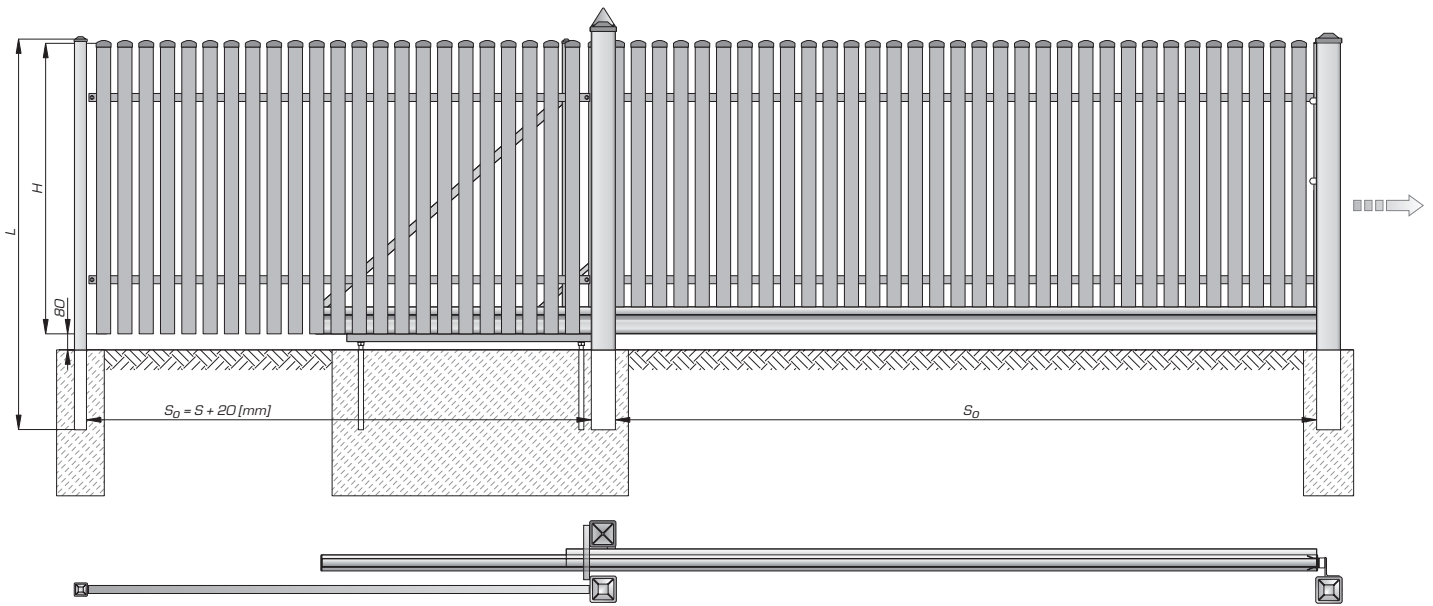

AW.10.16/P

(S) 2500 [mm] x (H) 900 [mm] - 47 kg	(S) 3000 [mm] x (H) 1200 [mm] - 69 kg
(S) 2500 [mm] x (H) 1200 [mm] - 57 kg	(S) 3000 [mm] x (H) 1450 [mm] - 81 kg
(S) 2500 [mm] x (H) 1450 [mm] - 67 kg	
max: (S) 3000 [mm] x (H) 1750 [mm]	

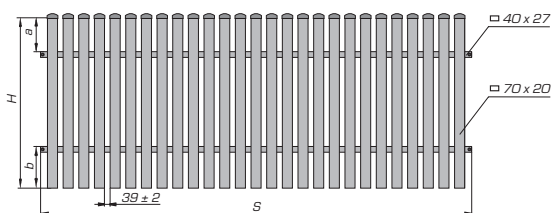

$H \geq 1000$: a=250, b=300, $H_{min}=800$	$800 \leq H < 1000$: a=250, b=200, $H_{min}=800$
---	---

AW.10.16/Wp

(S) 2500 [mm] x (H) 900 [mm] - 44 kg	(S) 3000 [mm] x (H) 1200 [mm] - 66 kg
(S) 2500 [mm] x (H) 1200 [mm] - 54 kg	(S) 3000 [mm] x (H) 1450 [mm] - 78 kg
(S) 2500 [mm] x (H) 1450 [mm] - 64 kg	
max: (S) 3000 [mm] x (H) 1750 [mm]	

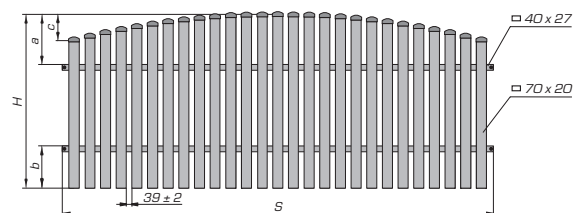

$H \geq 1100$: a=350, b=300, c=175, $H_{min}=900$	$900 \leq H < 1100$: a=350, b=200, c=175, $H_{min}=900$
--	--

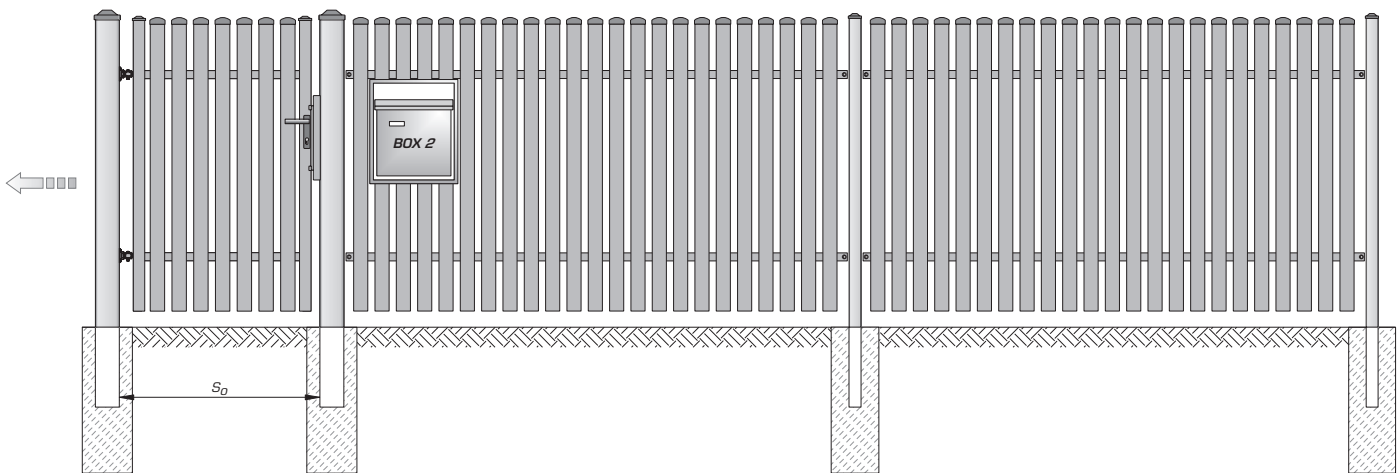
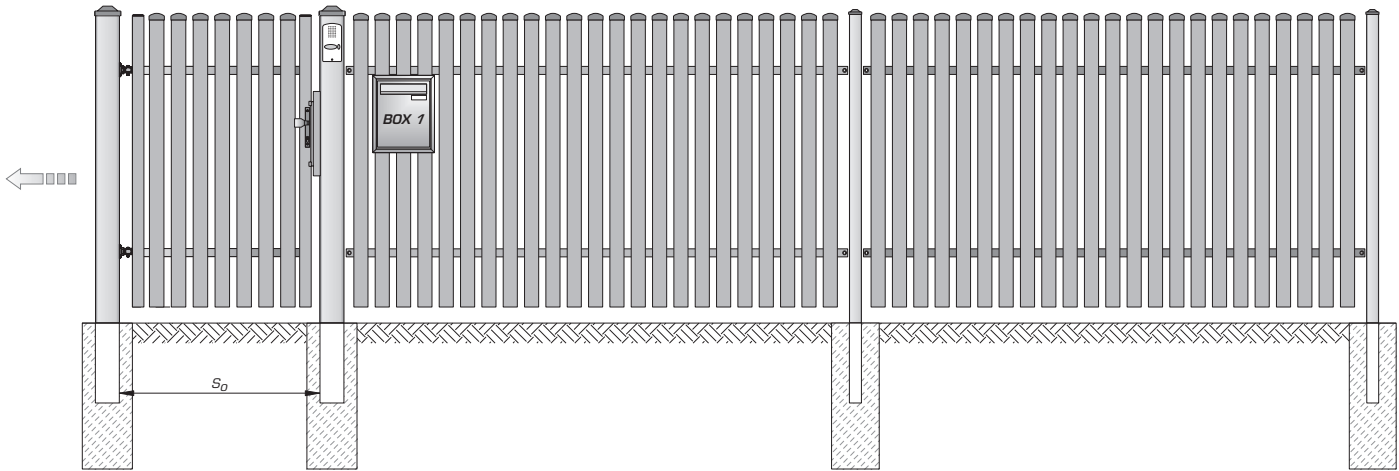

AW.10.16/Wk

(S) 2500 [mm] x (H) 900 [mm] - 44 kg	(S) 3000 [mm] x (H) 1200 [mm] - 66 kg
(S) 2500 [mm] x (H) 1200 [mm] - 54 kg	(S) 3000 [mm] x (H) 1450 [mm] - 78 kg
(S) 2500 [mm] x (H) 1450 [mm] - 64 kg	
max: (S) 3000 [mm] x (H) 1750 [mm]	

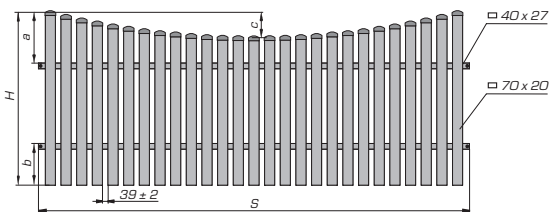

$H \geq 1100$: $a=350, b=300, c=175, H_{min}=900$ $900 \leq H < 1100$: $a=350, b=200, c=175, H_{min}=900$

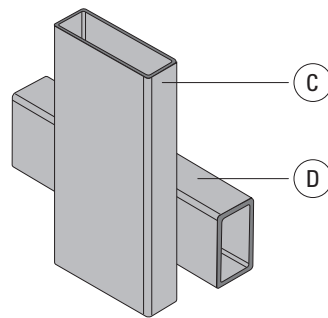

U1 C 70x20 D 40x27



System Classic
AW.10.17

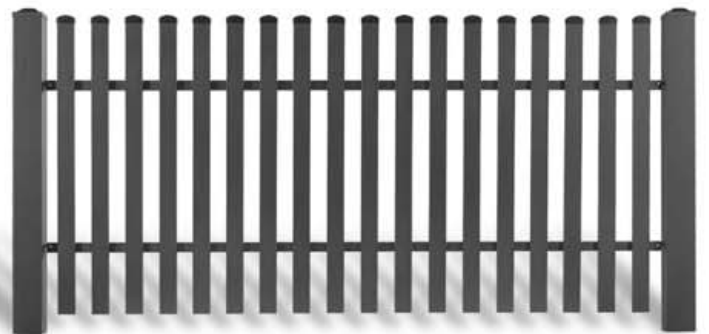

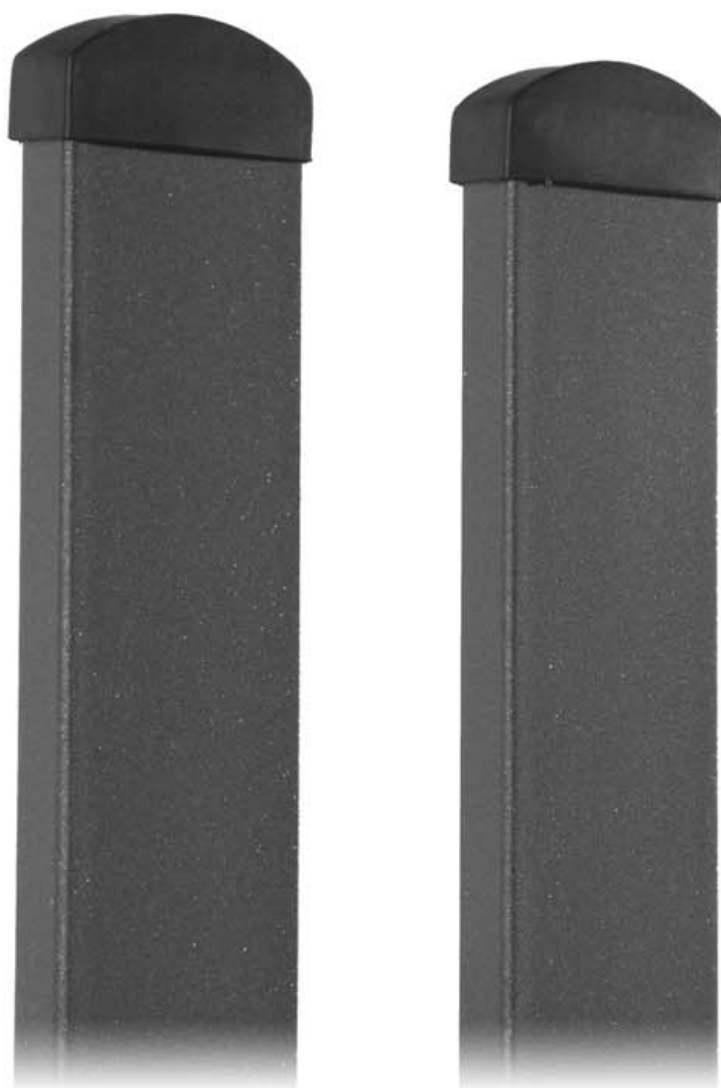

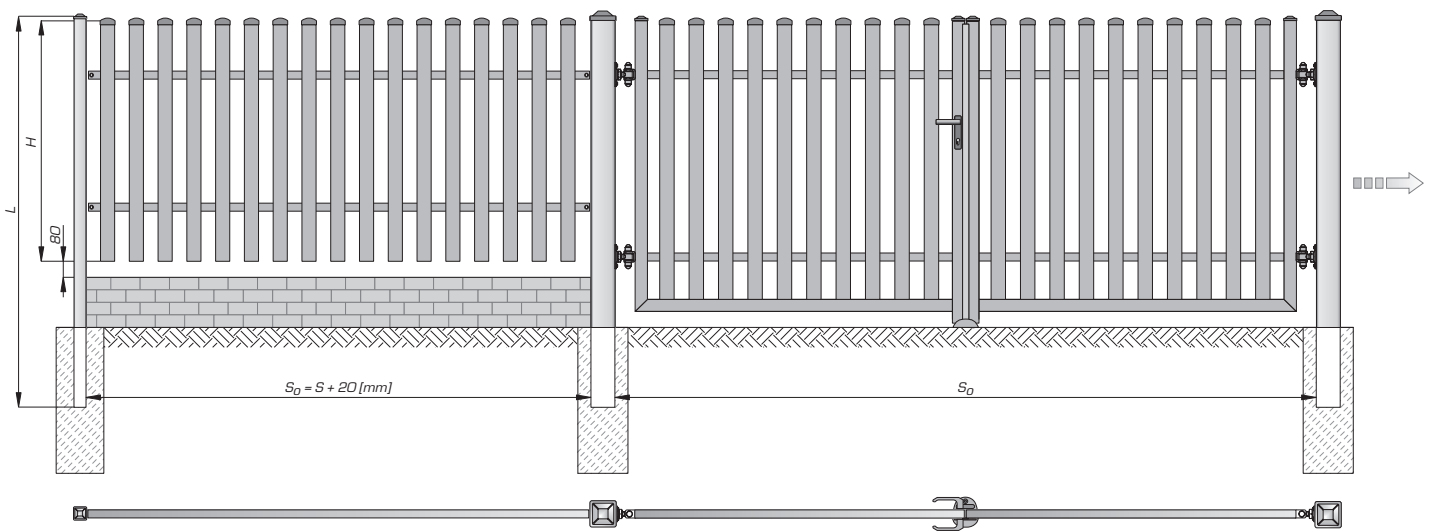
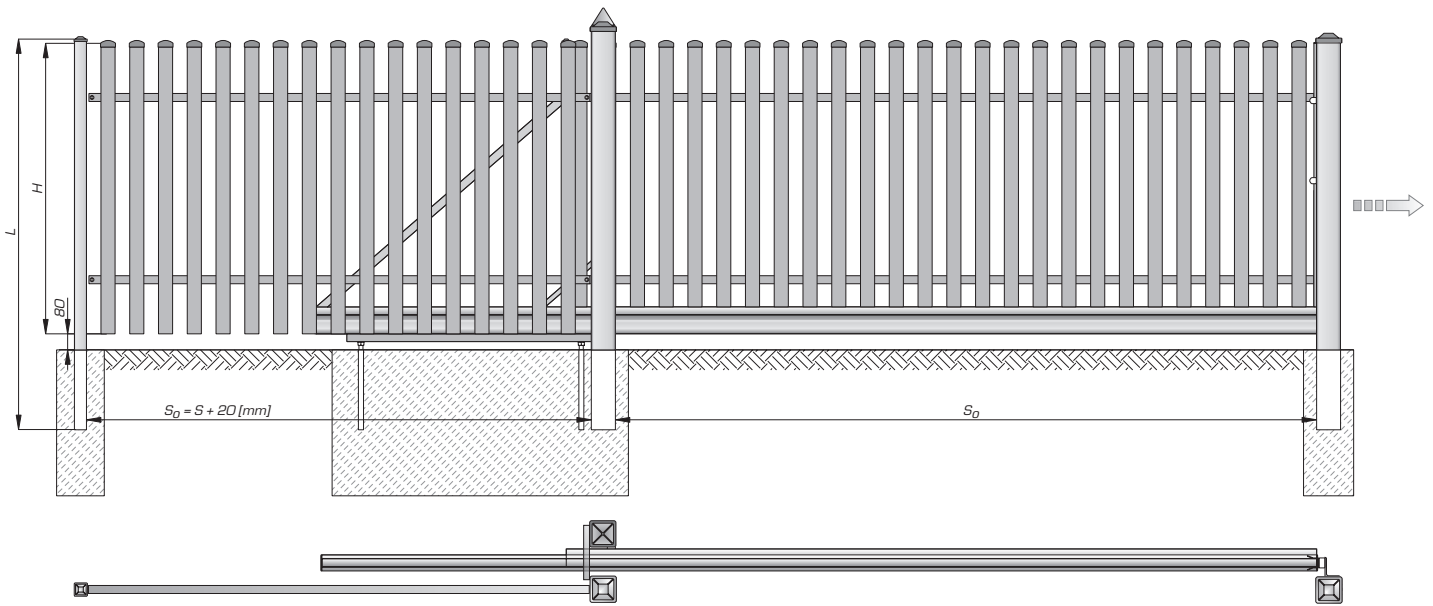

AW.10.17/P

(S) 2500 [mm] x (H) 900 [mm] - 40 kg	(S) 3000 [mm] x (H) 1200 [mm] - 56 kg
(S) 2500 [mm] x (H) 1200 [mm] - 47 kg	(S) 3000 [mm] x (H) 1450 [mm] - 66 kg
(S) 2500 [mm] x (H) 1450 [mm] - 54 kg	
max: (S) 3000 [mm] x (H) 1750 [mm]	

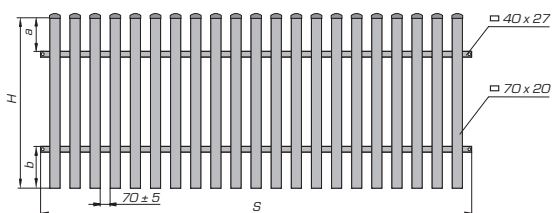

$H \geq 1000$: $a=250$, $b=300$, $H_{min}=800$ $800 \leq H < 1000$: $a=250$, $b=200$, $H_{min}=800$

AW.10.17/Wp

(S) 2500 [mm] x (H) 900 [mm] - 38 kg	(S) 3000 [mm] x (H) 1200 [mm] - 54 kg
(S) 2500 [mm] x (H) 1200 [mm] - 45 kg	(S) 3000 [mm] x (H) 1450 [mm] - 64 kg
(S) 2500 [mm] x (H) 1450 [mm] - 52 kg	
max: (S) 3000 [mm] x (H) 1750 [mm]	

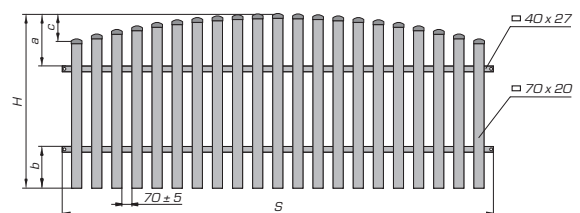

$H \geq 1100$: $a=350$, $b=300$, $c=175$, $H_{min}=900$ $900 \leq H < 1100$: $a=350$, $b=200$, $c=175$, $H_{min}=900$

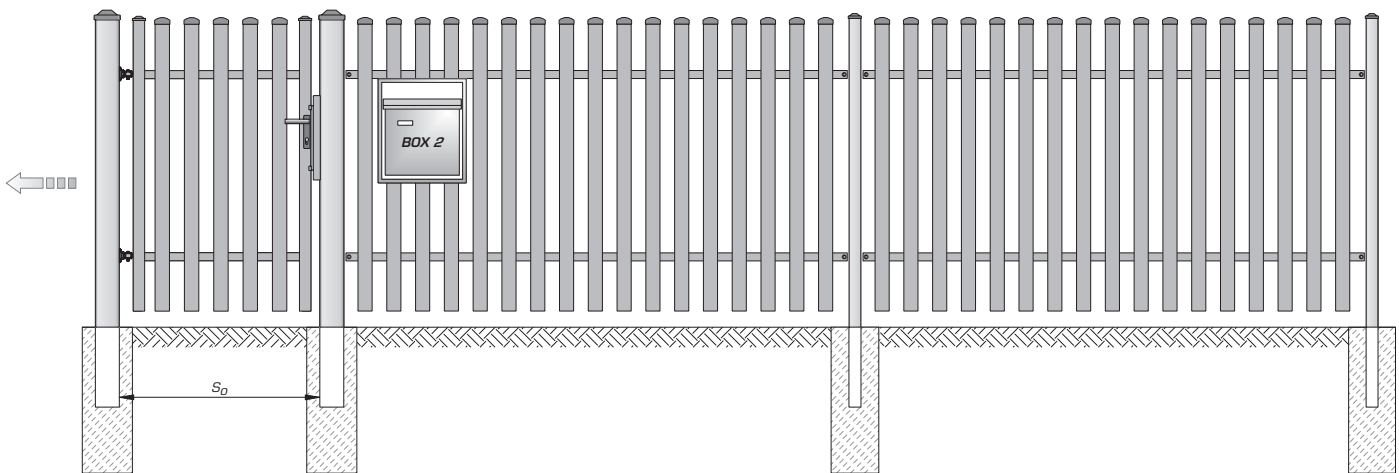
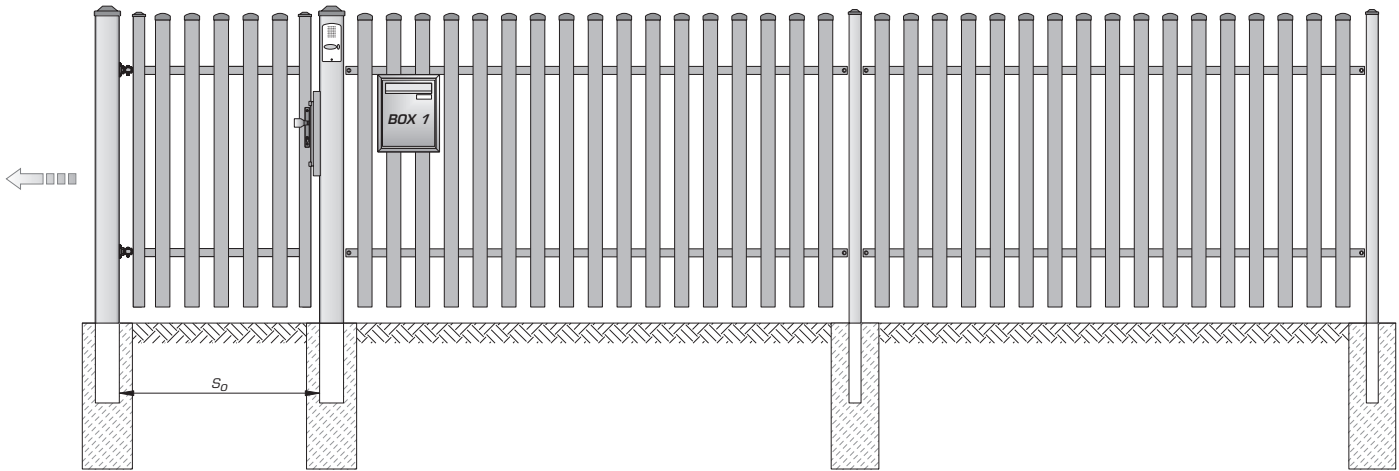

AW.10.17/Wk

(S) 2500 [mm] x (H) 900 [mm] - 38 kg	(S) 3000 [mm] x (H) 1200 [mm] - 54 kg
(S) 2500 [mm] x (H) 1200 [mm] - 45 kg	(S) 3000 [mm] x (H) 1450 [mm] - 64 kg
(S) 2500 [mm] x (H) 1450 [mm] - 52 kg	
max: (S) 3000 [mm] x (H) 1750 [mm]	

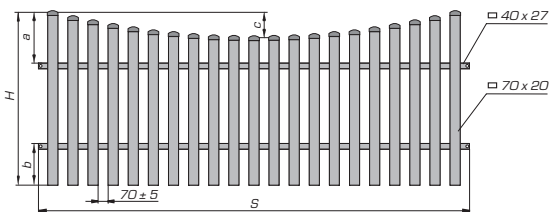

$H \geq 1100$: $a=350, b=300, c=175, H_{min}=900$ $900 \leq H < 1100$: $a=350, b=200, c=175, H_{min}=900$

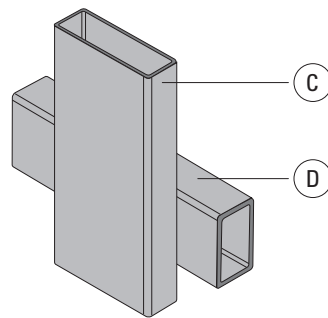

U1 C 70x20 D 40x27



System Classic
AW.10.30

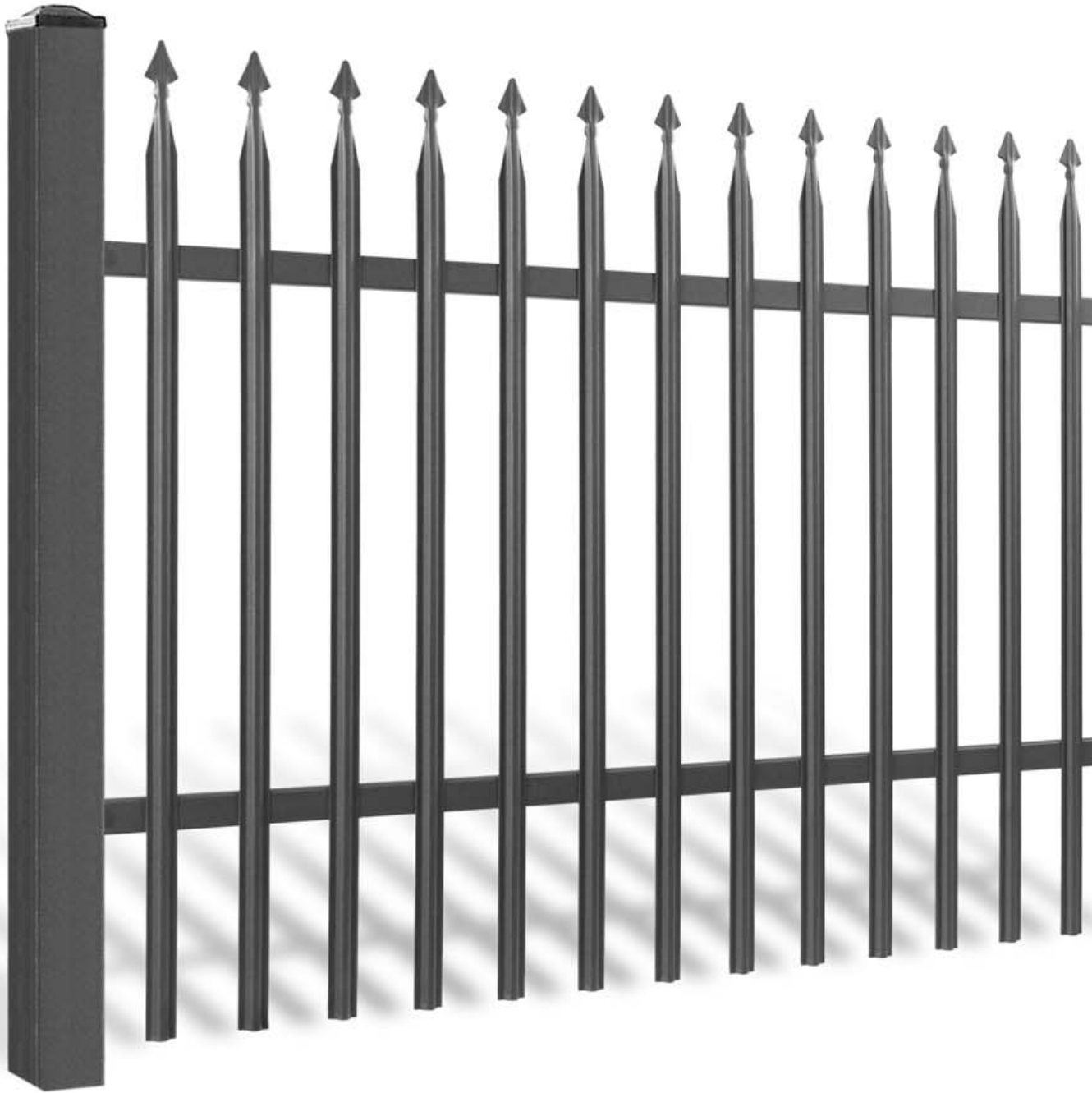

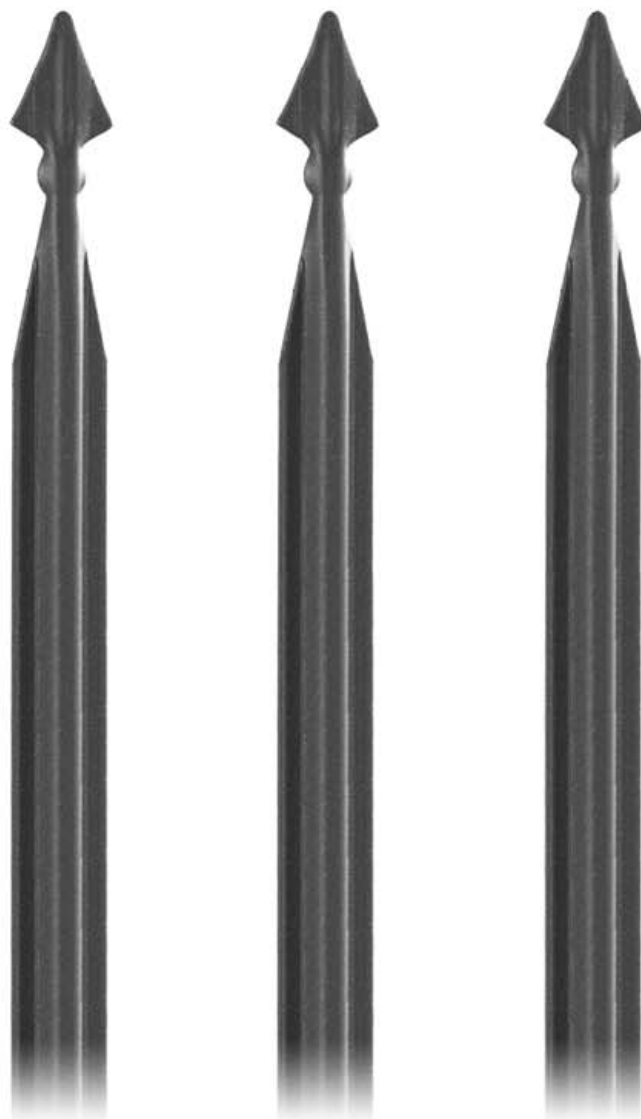

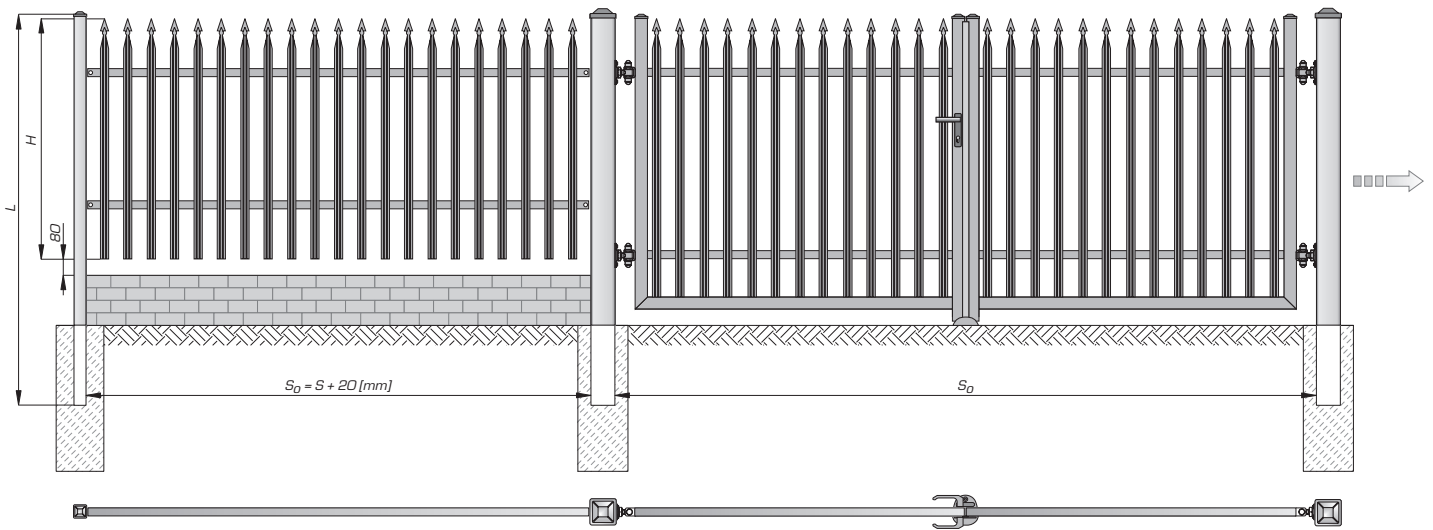
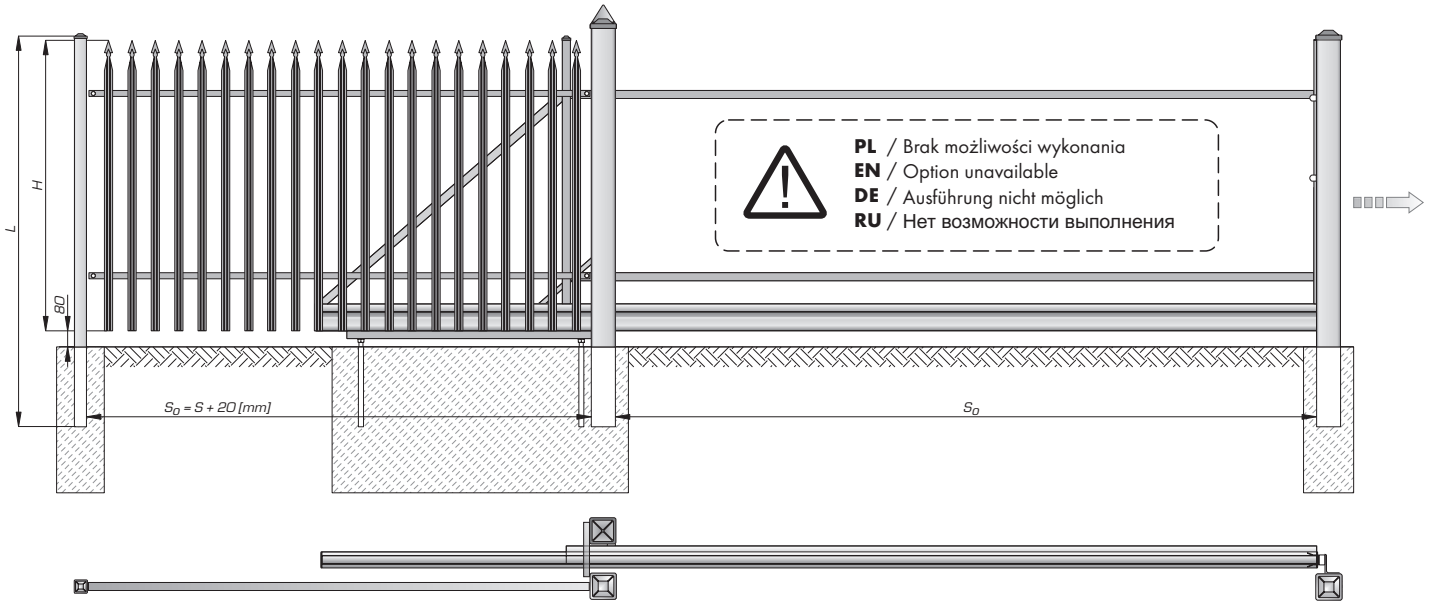

AW.10.30/P

(S) 2500 [mm] x (H) 900 [mm] - 26 kg	(S) 3000 [mm] x (H) 1200 [mm] - 38 kg
(S) 2500 [mm] x (H) 1200 [mm] - 32 kg	(S) 3000 [mm] x (H) 1450 [mm] - 45 kg
(S) 2500 [mm] x (H) 1450 [mm] - 38 kg	
max: (S) 3000 [mm] x (H) 1750 [mm]	

$H \geq 1000$: a=250, b=300, $H_{min}=800$	$800 \leq H < 1000$: a=250, b=200, $H_{min}=800$
---	---

AW.10.30/Wp

(S) 2500 [mm] x (H) 900 [mm] - 24 kg	(S) 3000 [mm] x (H) 1200 [mm] - 36 kg
(S) 2500 [mm] x (H) 1200 [mm] - 30 kg	(S) 3000 [mm] x (H) 1450 [mm] - 43 kg
(S) 2500 [mm] x (H) 1450 [mm] - 36 kg	
max: (S) 3000 [mm] x (H) 1750 [mm]	

$H \geq 1100$: a=350, b=300, c=175, $H_{min}=900$	$900 \leq H < 1100$: a=350, b=200, c=175, $H_{min}=900$
--	--

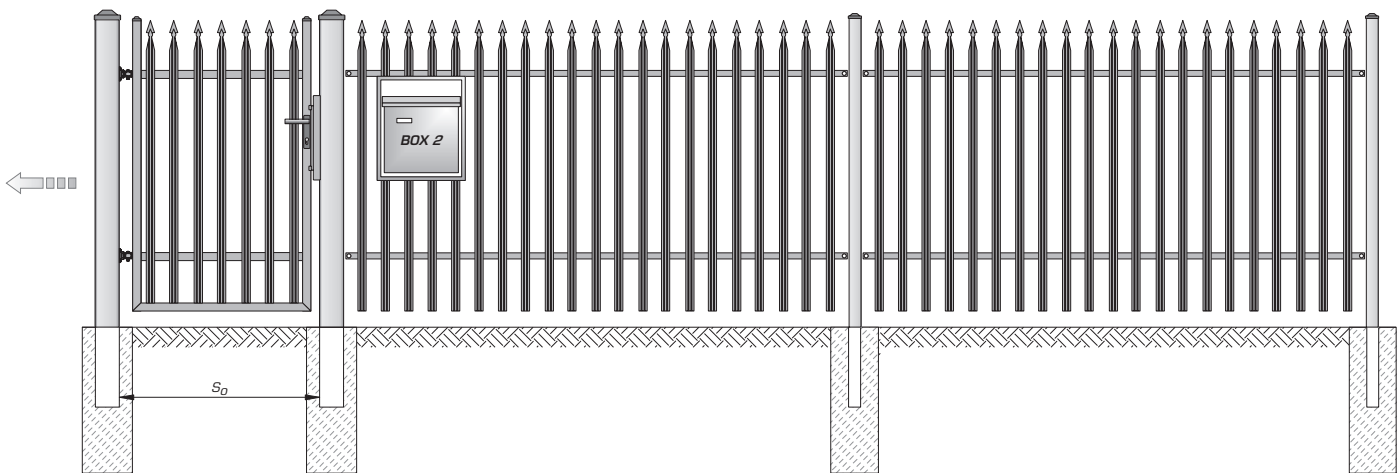
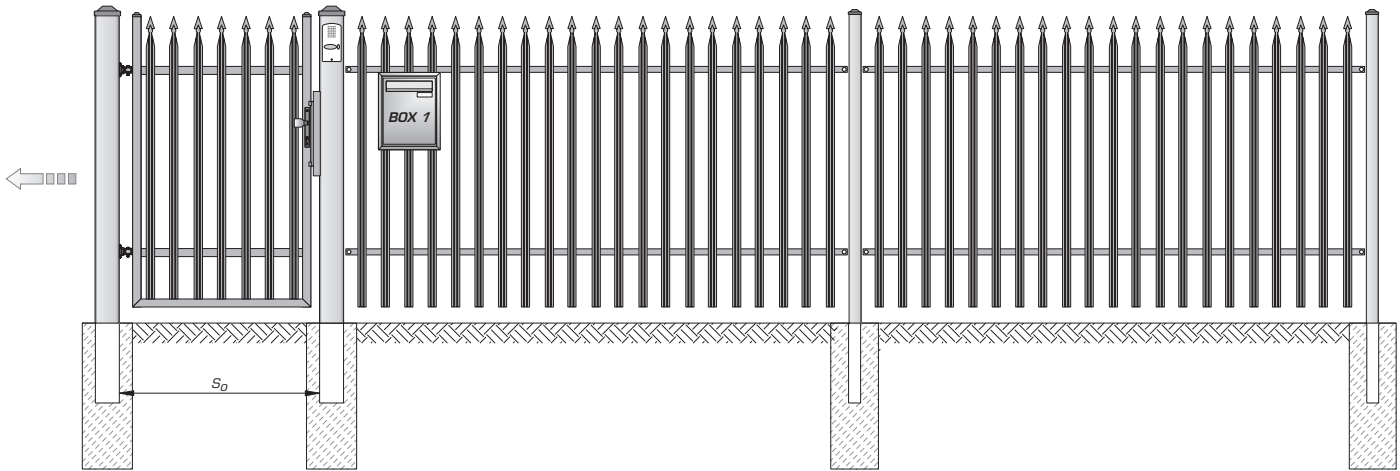

AW.10.30/Wk

(S) 2500 [mm] x (H) 900 [mm] - 24 kg	(S) 3000 [mm] x (H) 1200 [mm] - 36 kg
(S) 2500 [mm] x (H) 1200 [mm] - 30 kg	(S) 3000 [mm] x (H) 1450 [mm] - 43 kg
(S) 2500 [mm] x (H) 1450 [mm] - 36 kg	
max: (S) 3000 [mm] x (H) 1750 [mm]	

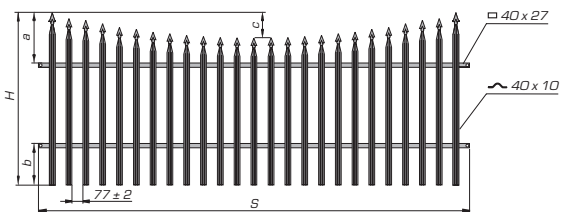

$H \geq 1100$: $a=350, b=300, c=175, H_{min}=900$ $900 \leq H < 1100$: $a=350, b=200, c=175, H_{min}=900$

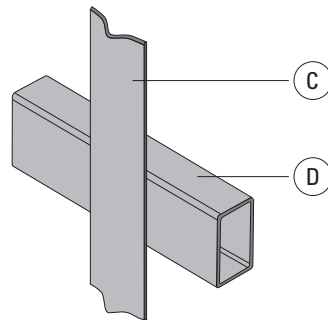

U1 C 40x10 D 40x27



System Classic
AW.10.37



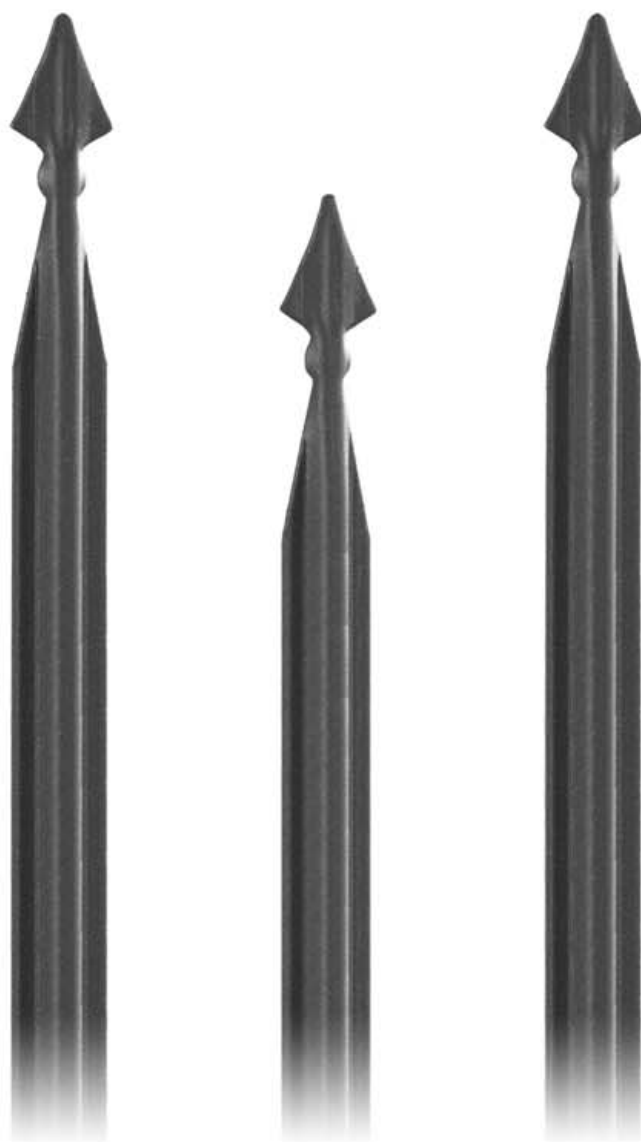

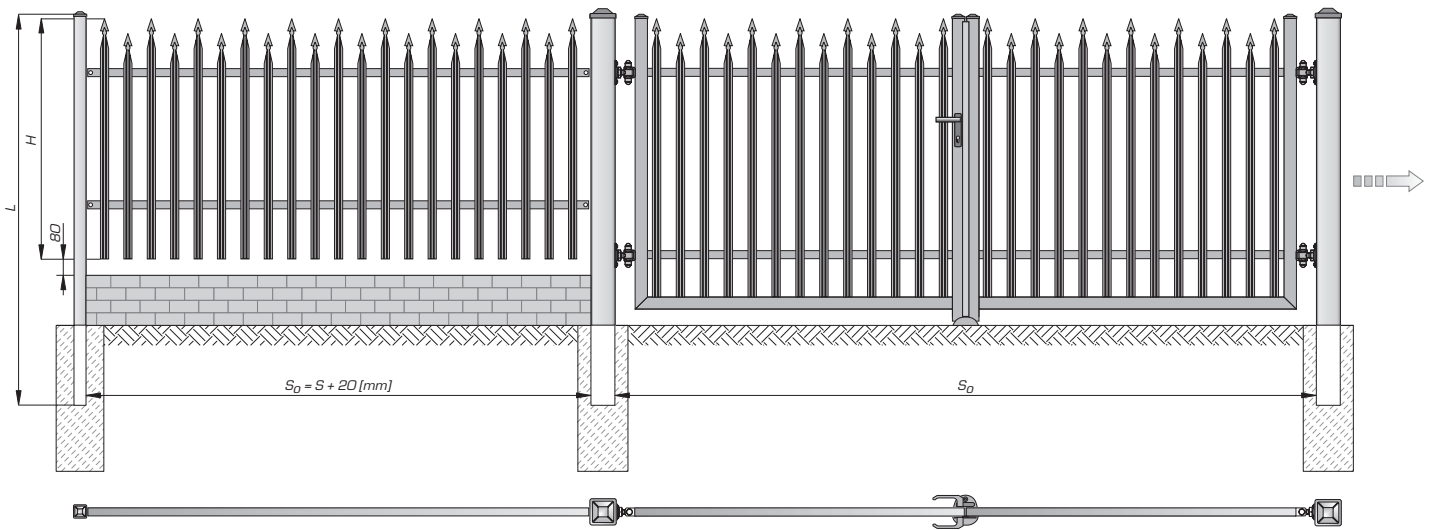
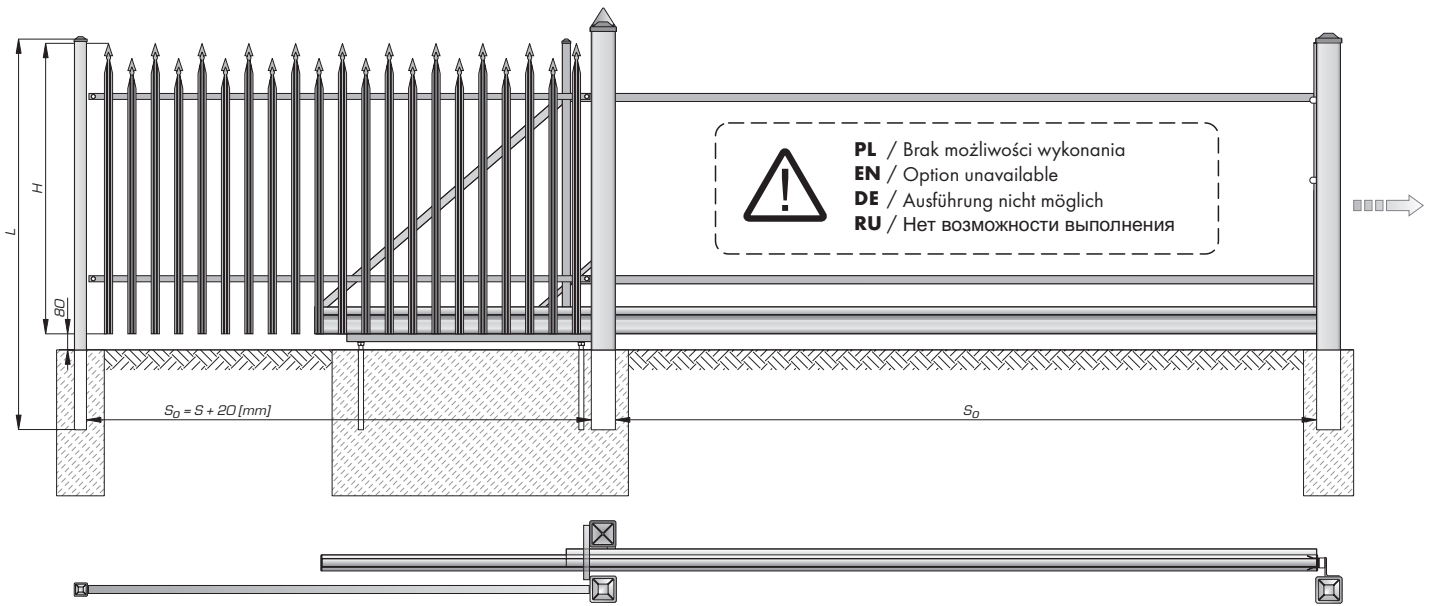

AW.10.37/P

(S) 2500 [mm] x (H) 900 [mm] - 26 kg	(S) 3000 [mm] x (H) 1200 [mm] - 38 kg
(S) 2500 [mm] x (H) 1200 [mm] - 32 kg	(S) 3000 [mm] x (H) 1450 [mm] - 44 kg
(S) 2500 [mm] x (H) 1450 [mm] - 38 kg	
max: (S) 3000 [mm] x (H) 1750 [mm]	

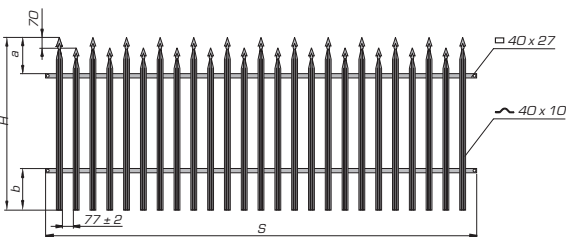

$H \geq 1000$: $a=250$, $b=300$, $H_{min}=800$	$800 \leq H < 1000$: $a=250$, $b=200$, $H_{min}=800$
---	---

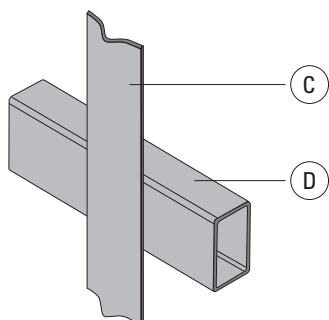
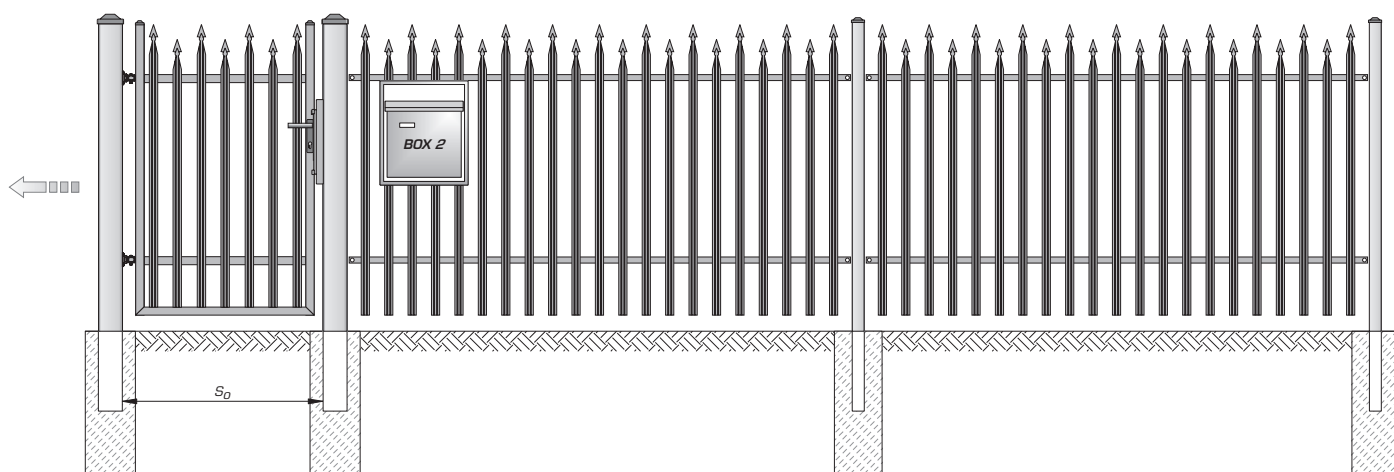
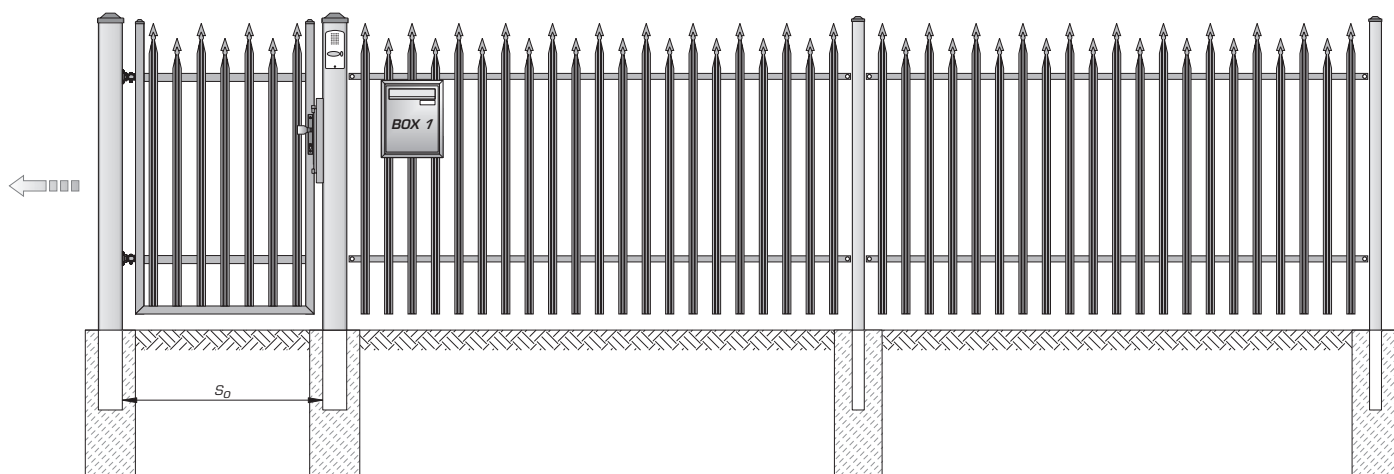

U1 C 40x10 D 40x27

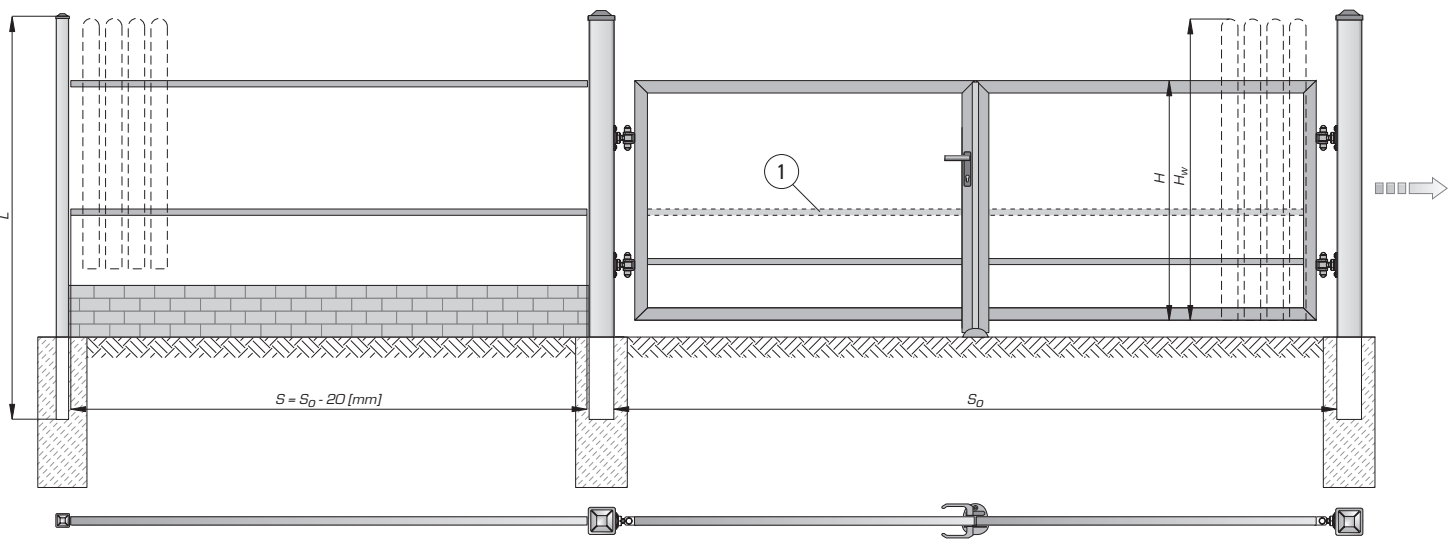
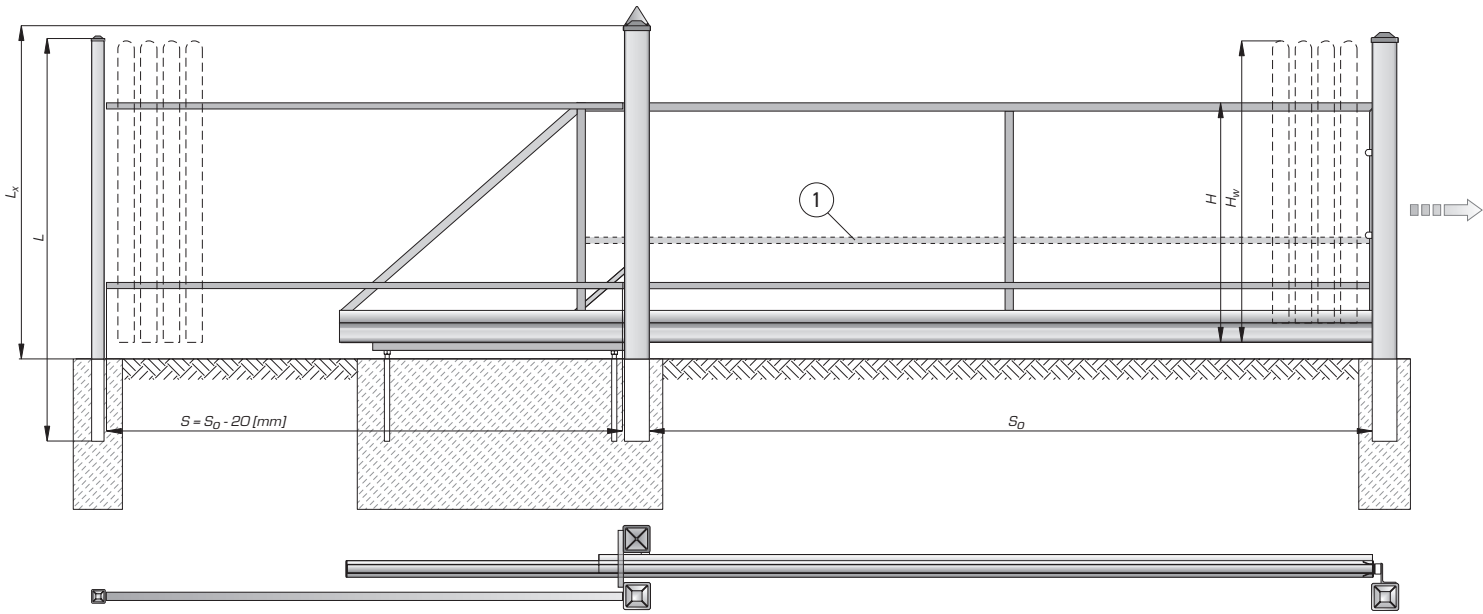

① $H > 1500$ [mm]

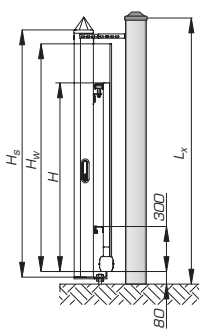

„R”

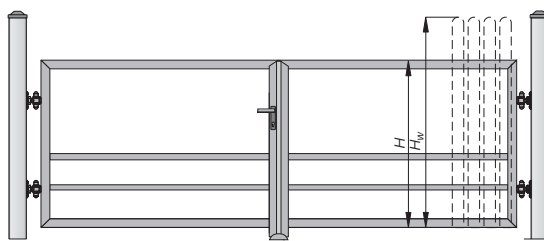

$H > 1500$ [mm]

„A”

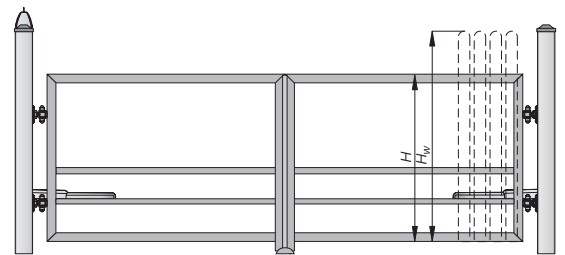

$H > 1500$ [mm]

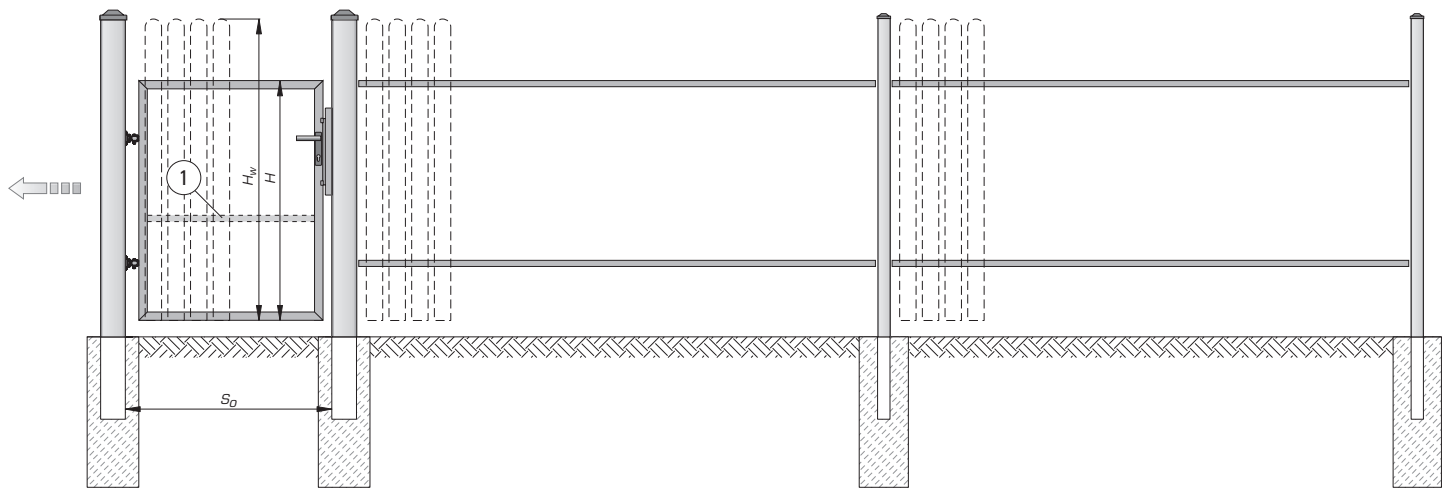
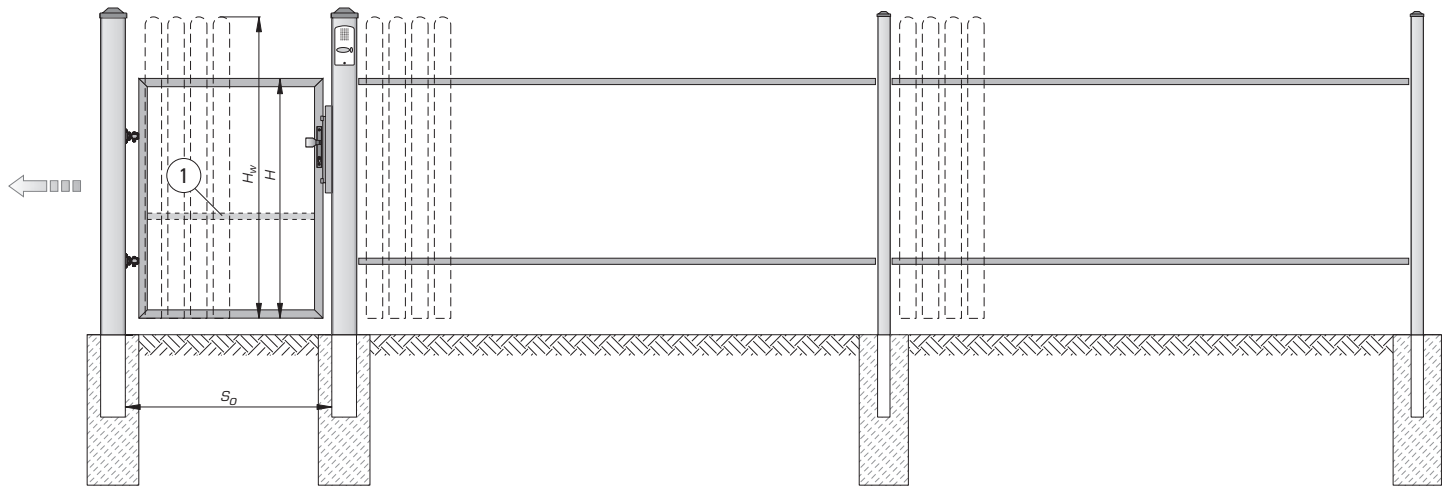

„R”

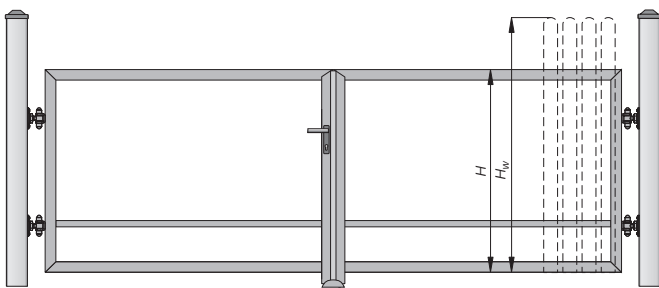

$H \leq 1500$ [mm]



„A”

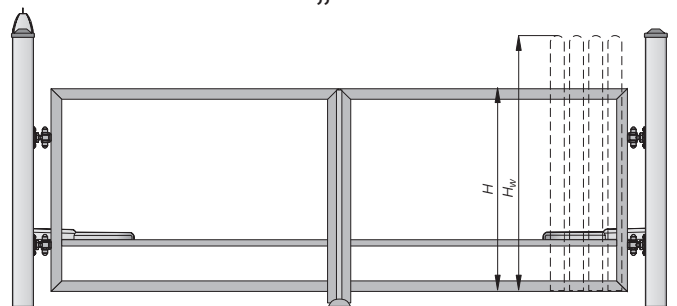

$H \leq 1500$ [mm]



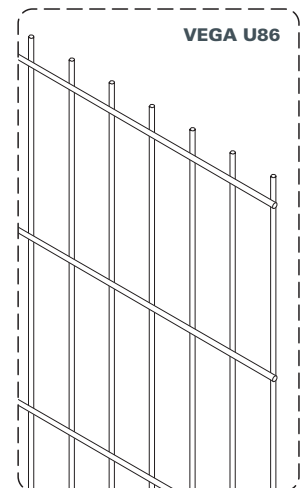
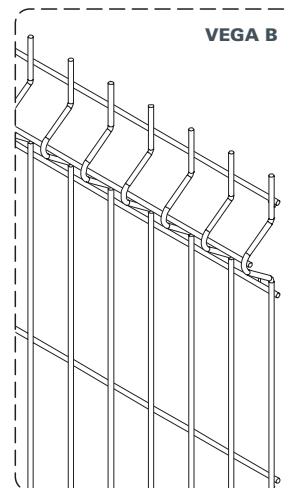
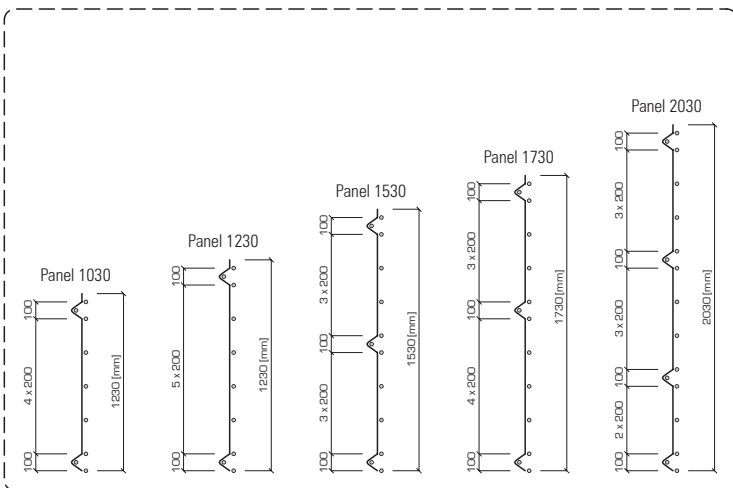
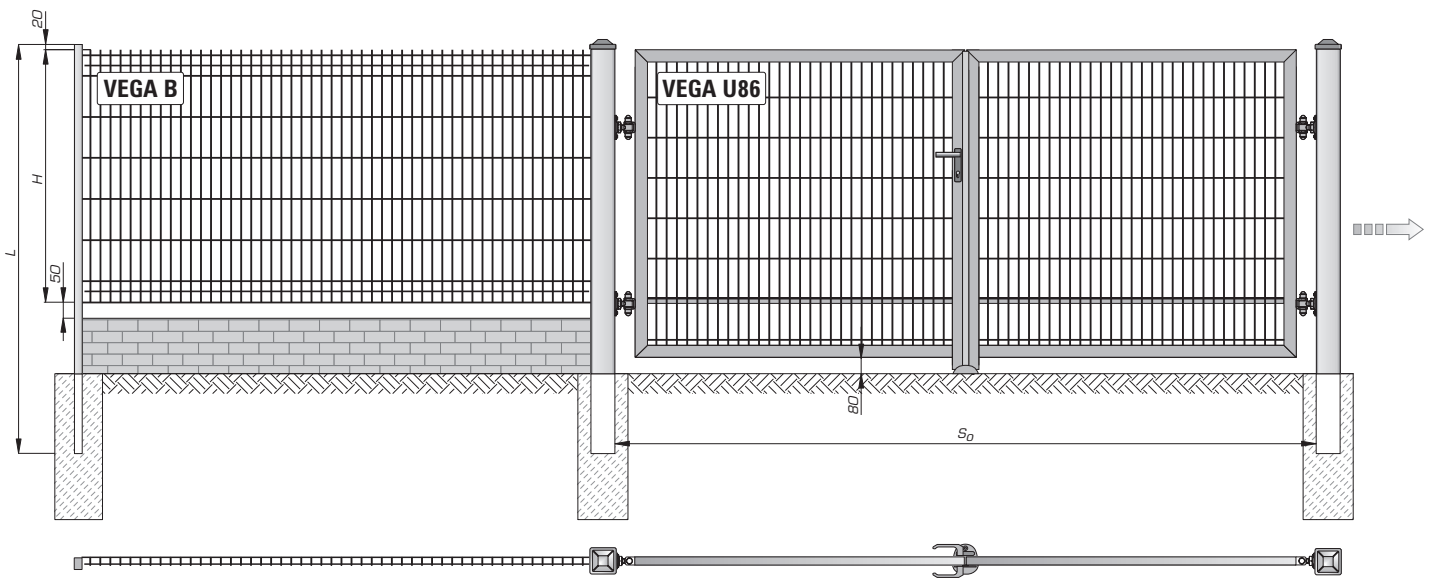
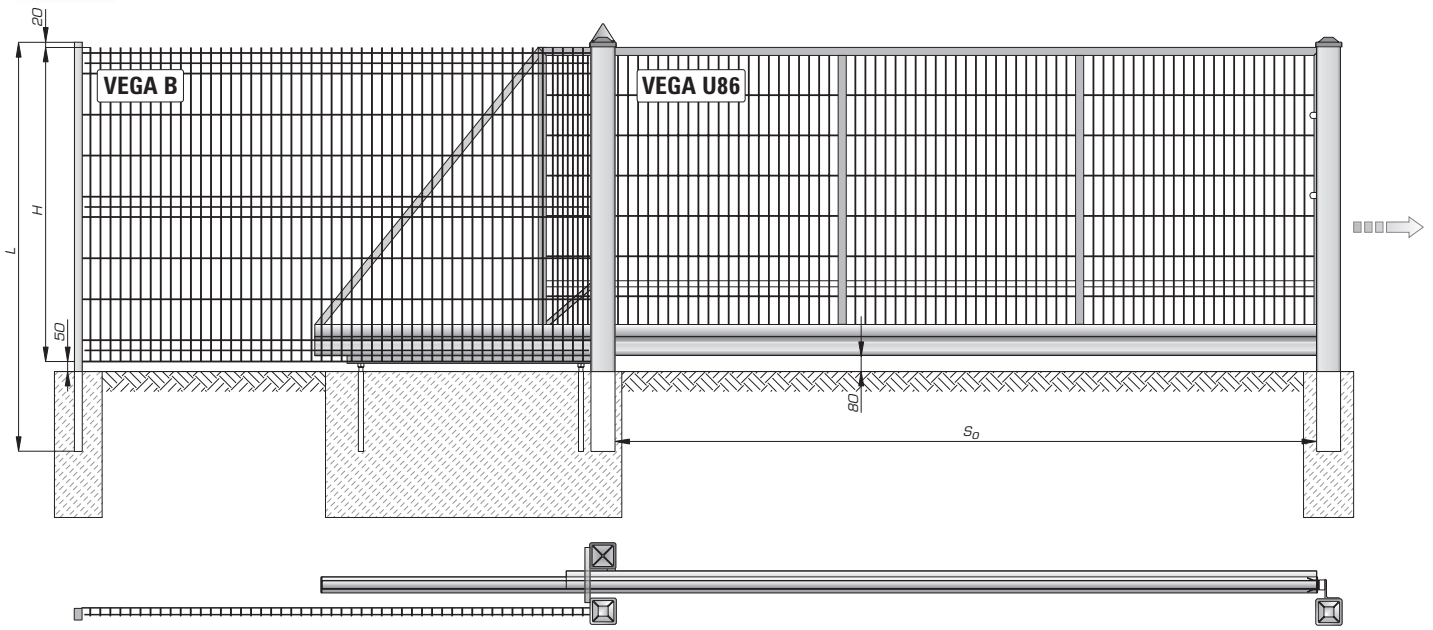

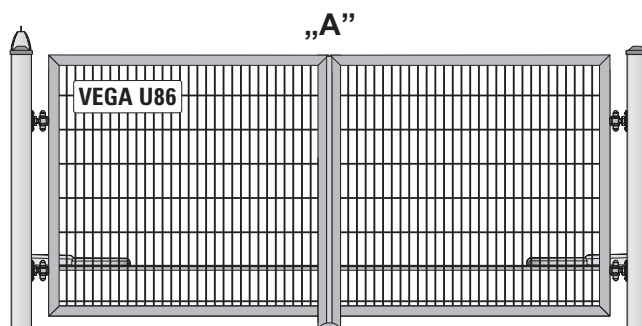
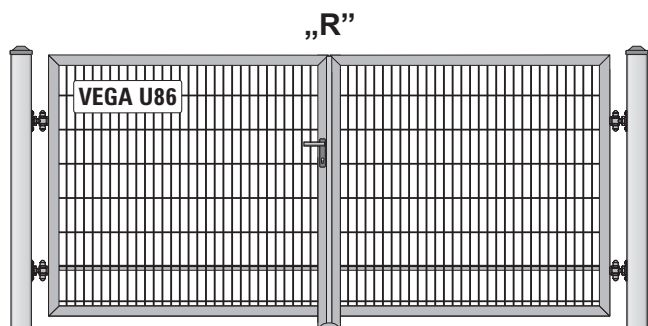
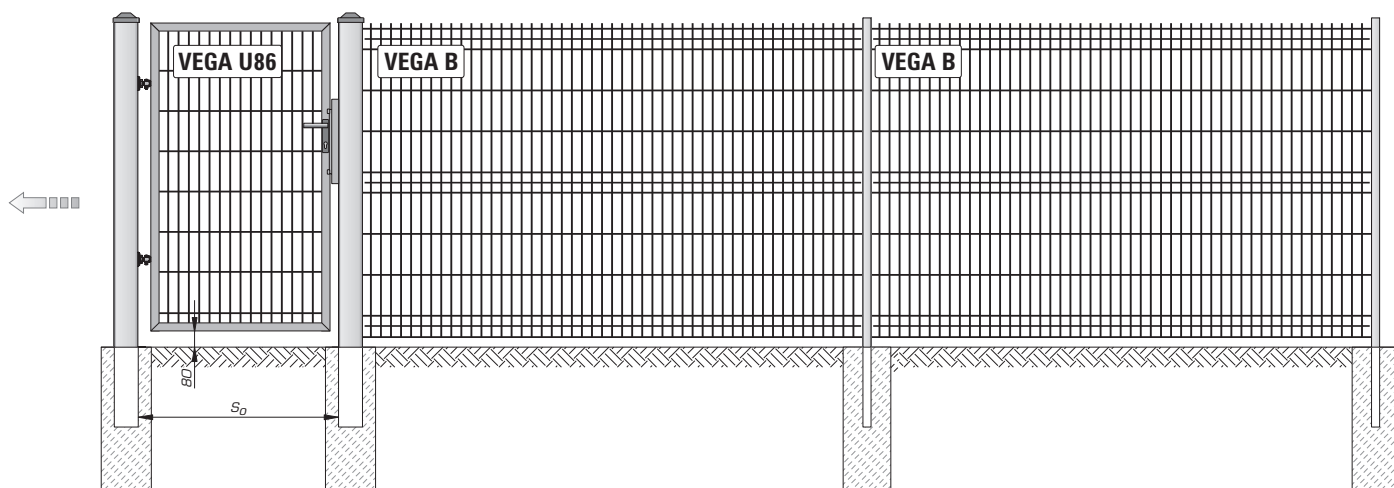
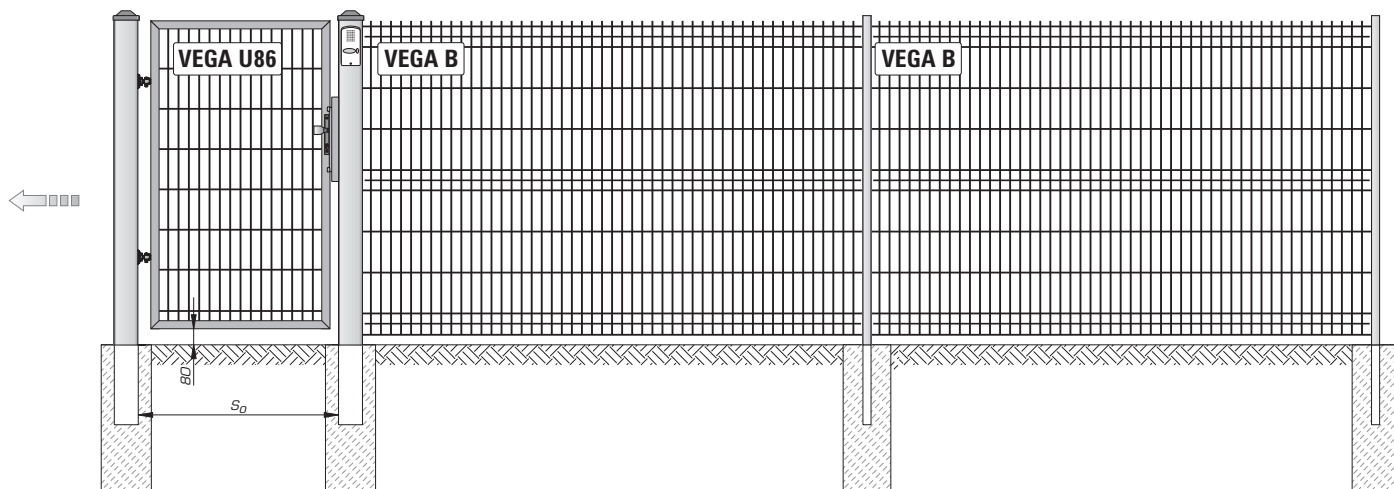

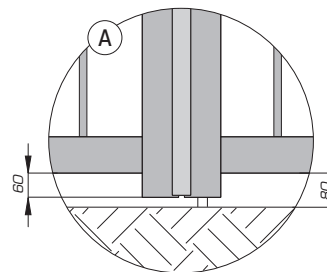
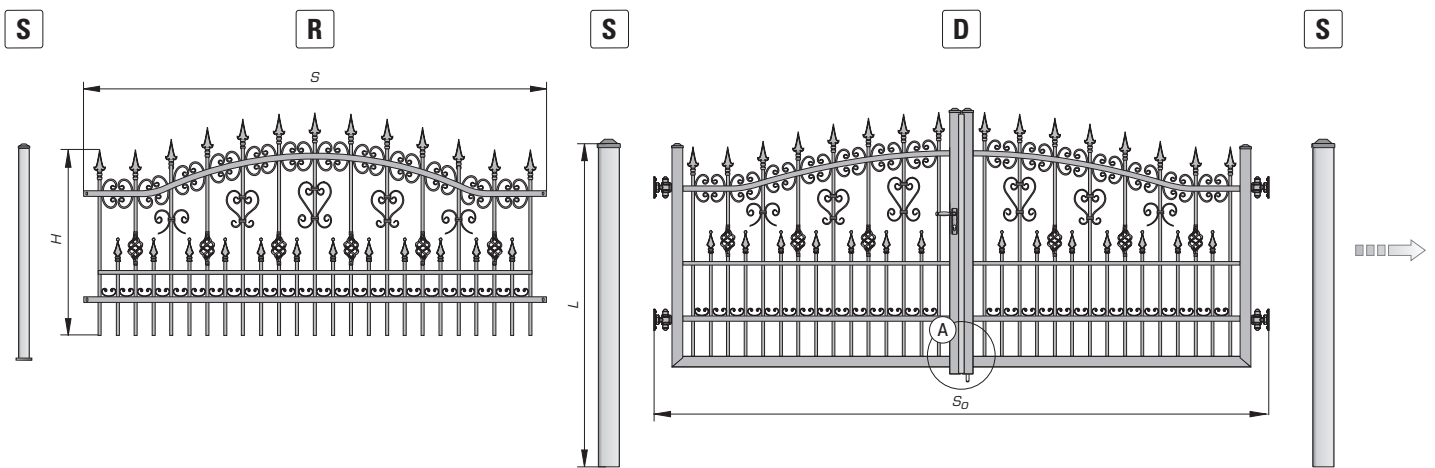
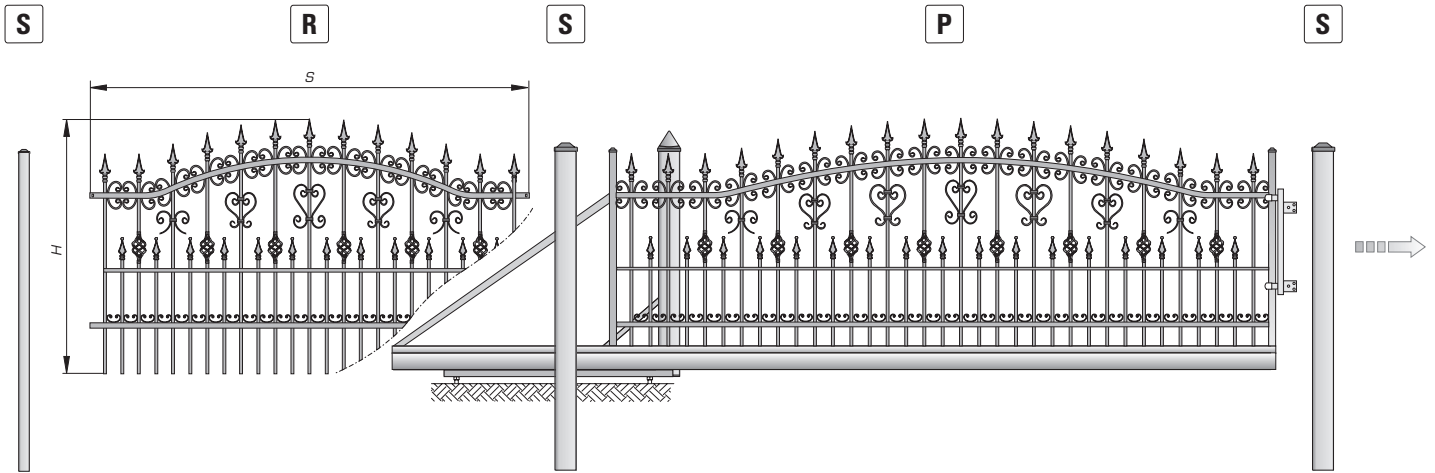

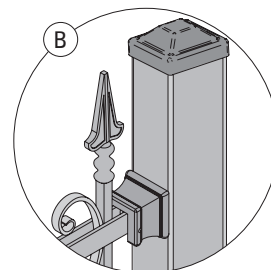
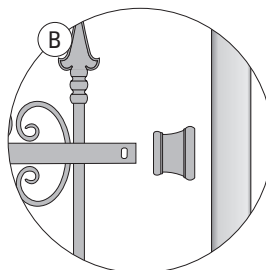
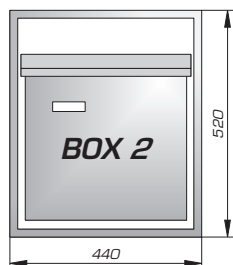
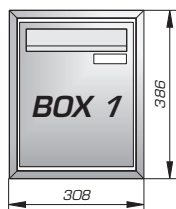
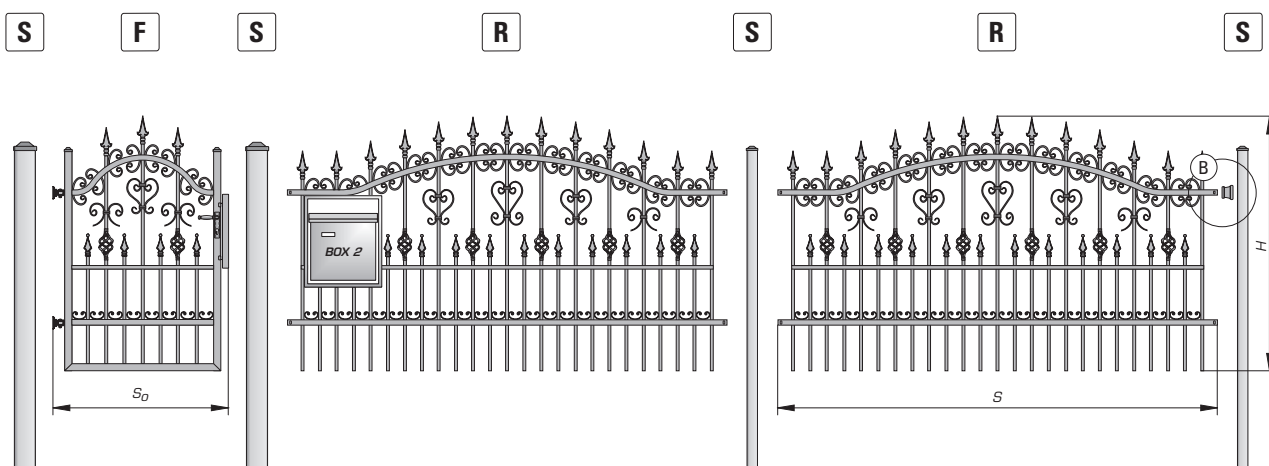
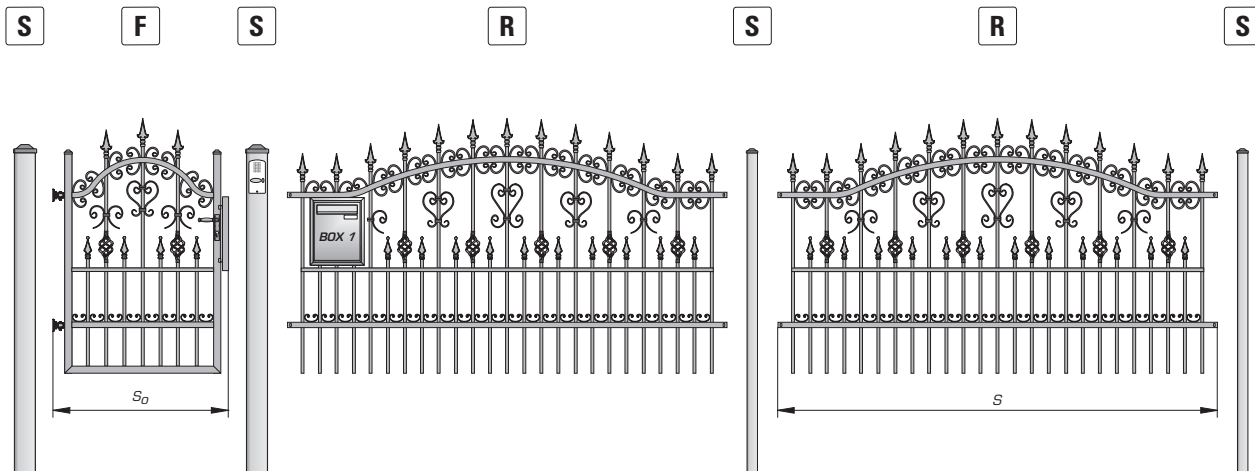

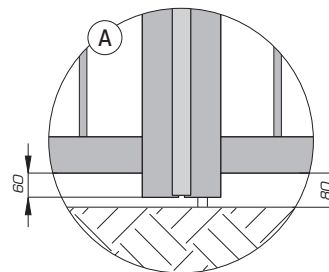
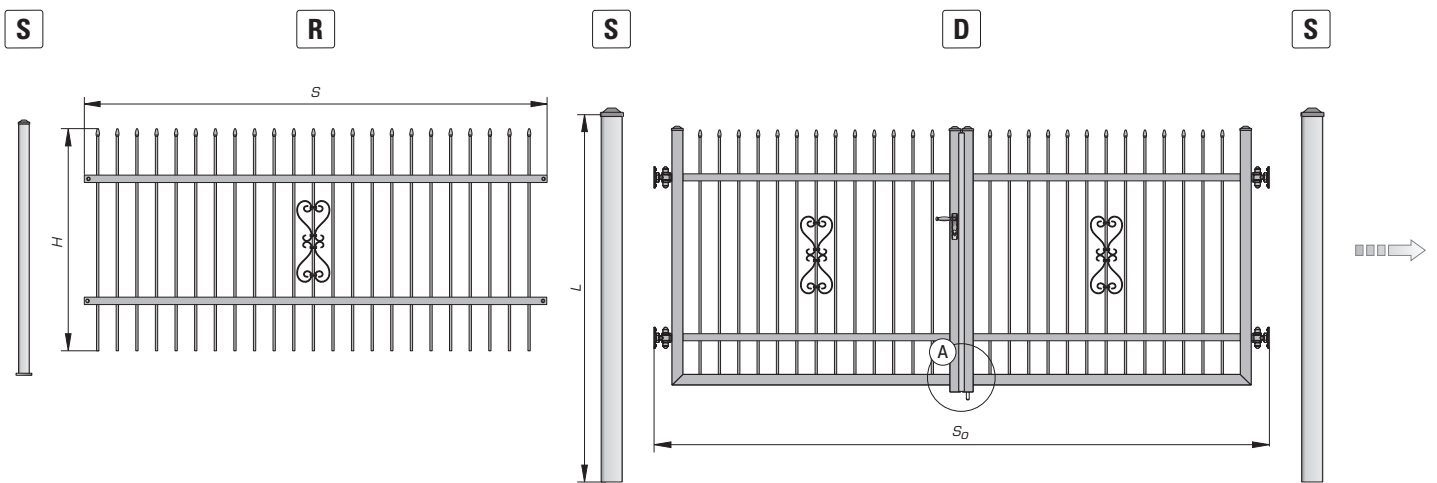
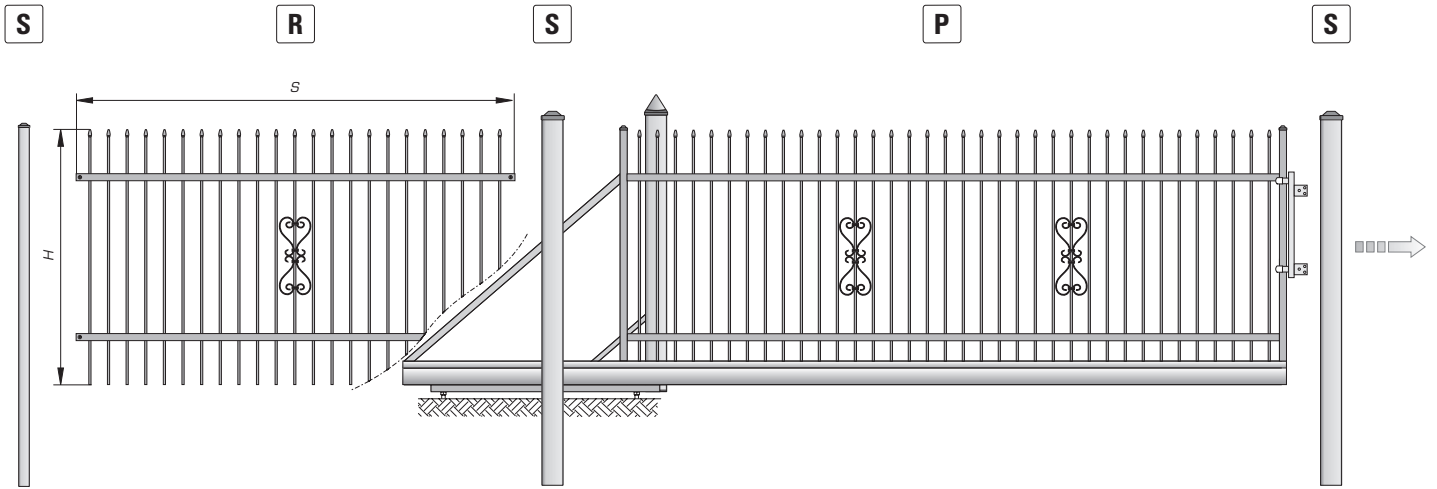

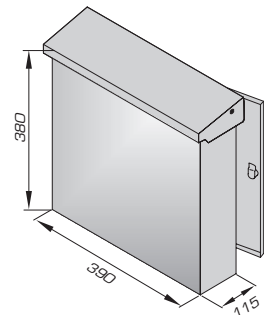
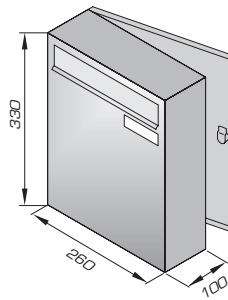
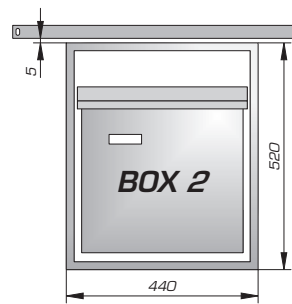
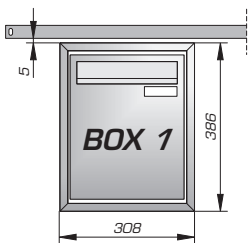
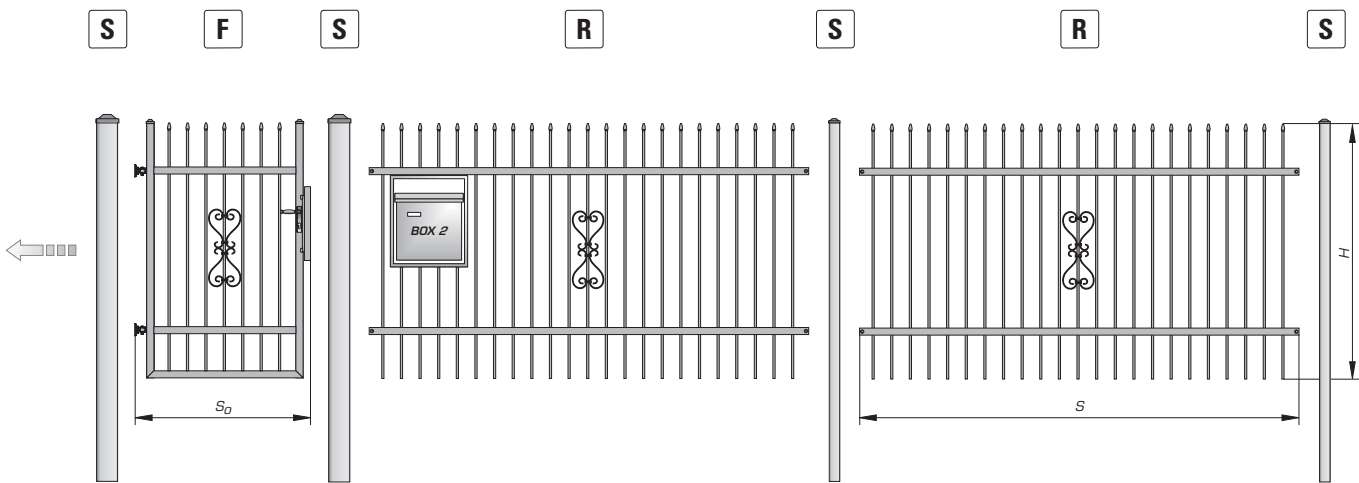
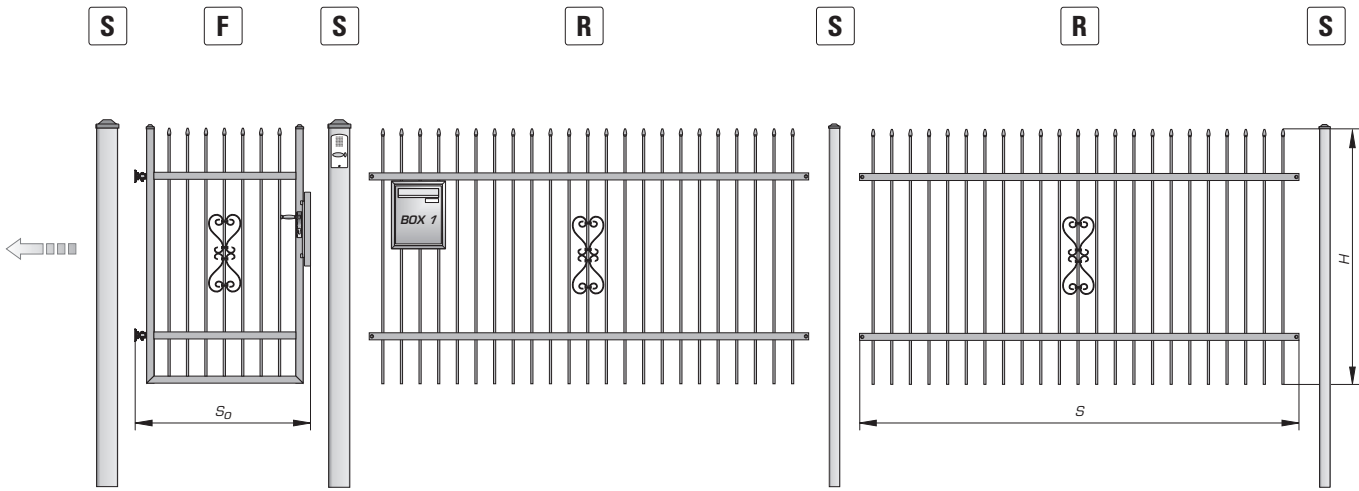

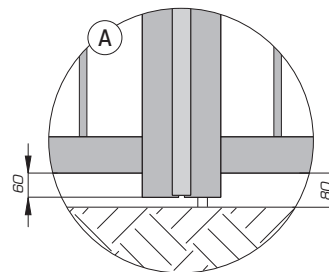
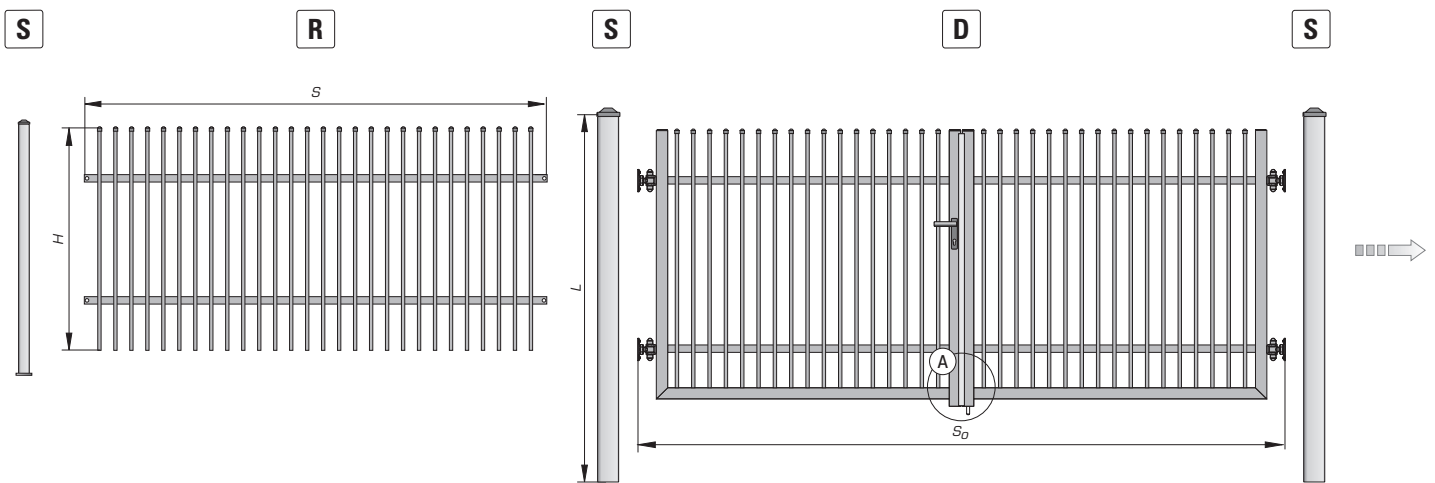
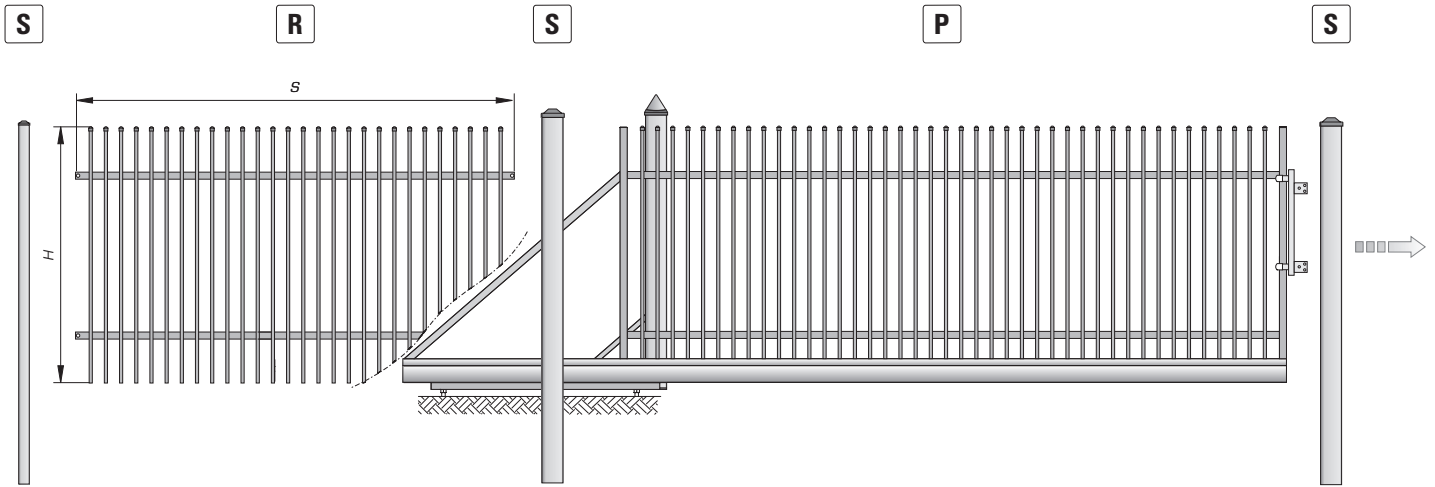

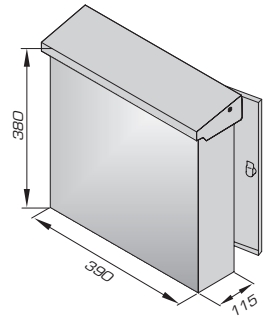
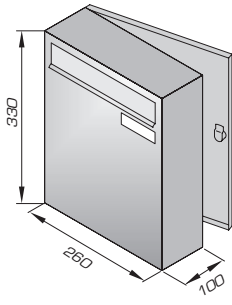
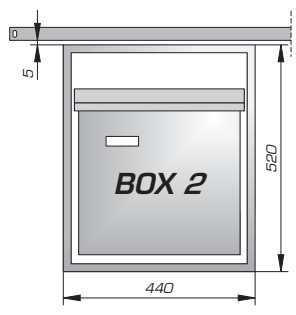
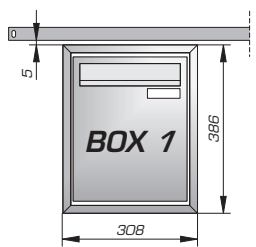
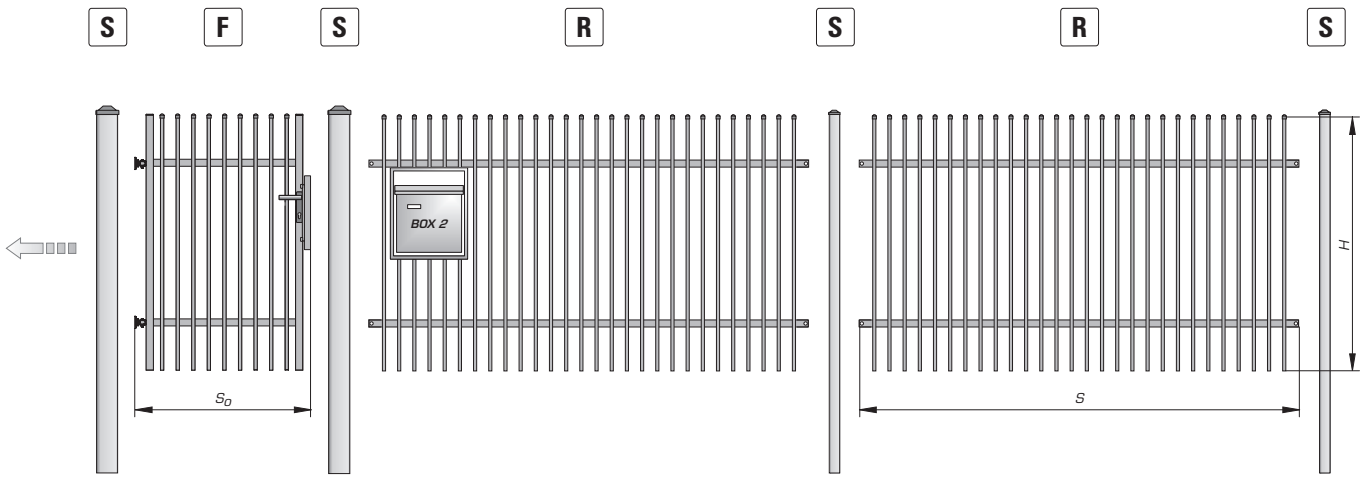
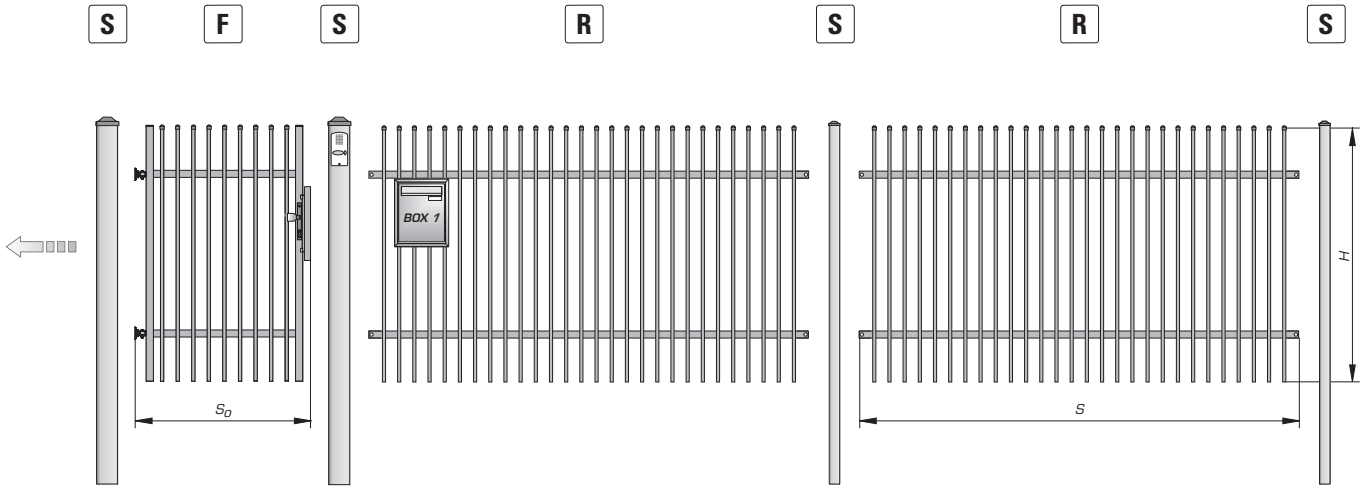



System **Loux** ▪ *Style* ▪ **Classic**

Groty ▪ Bar heads and tops ▪ Zaunspitze ▪ Наконечники

System **Loux**

SP

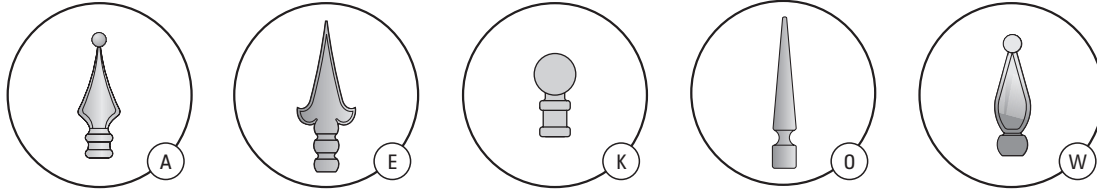

TOP

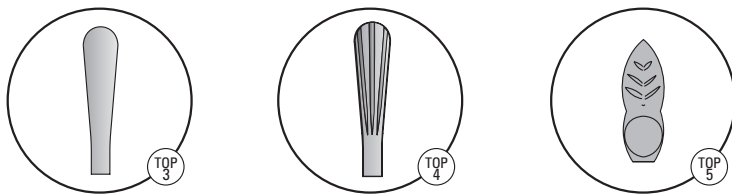

System *Style*

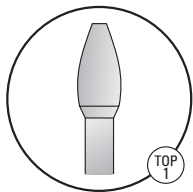

PL / Standard
EN / Standard
DE / Standard
RU / Стандарт

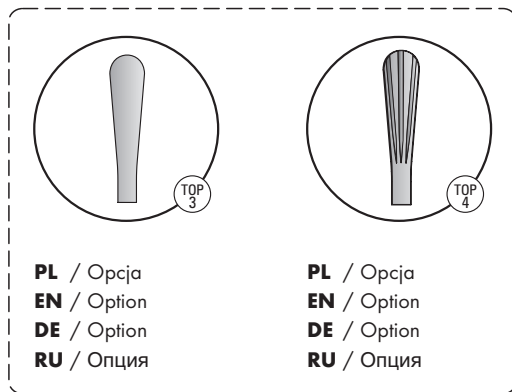

PL / Опція
EN / Option
DE / Option
RU / Опция

PL / Опція
EN / Option
DE / Option
RU / Опция

System **Classic**

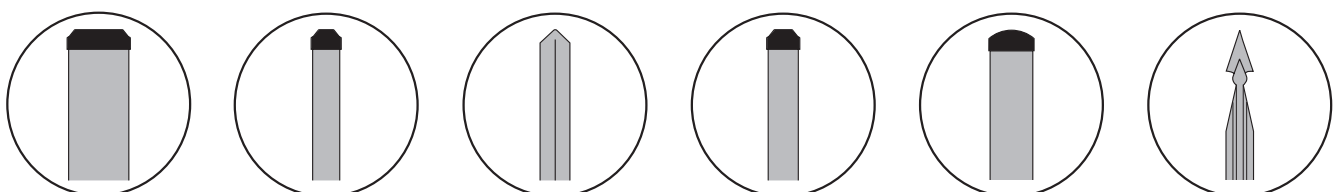

AW.10.01

AW.10.02

AW.10.03

AW.10.05
AW.10.06

AW.10.16
AW.10.17

AW.10.30
AW.10.37

- PL** / Konstrukcja zamknięta
- EN** / Closed construction
- DE** / Geschlossene Ausführung
- RU** / Закрытая конструкция

	RO(P)	RO(Wp)
System <i>Loûx</i>		
System <i>Style</i>		
	RC	
System <i>Classic</i>	<p style="text-align: center;">dla $H \leq 1400$ [mm]</p>	<p style="text-align: center;">$H > 1400$ [mm]</p>

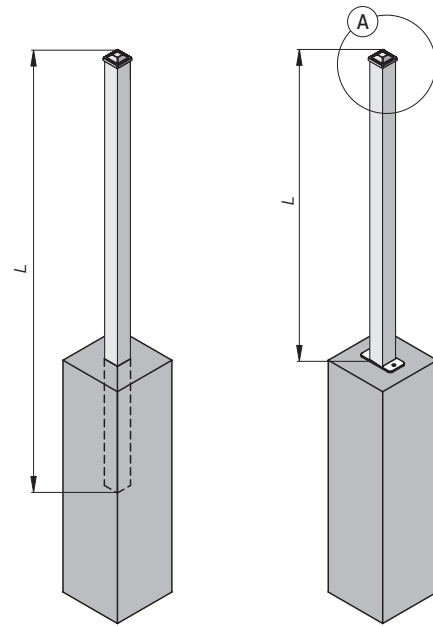
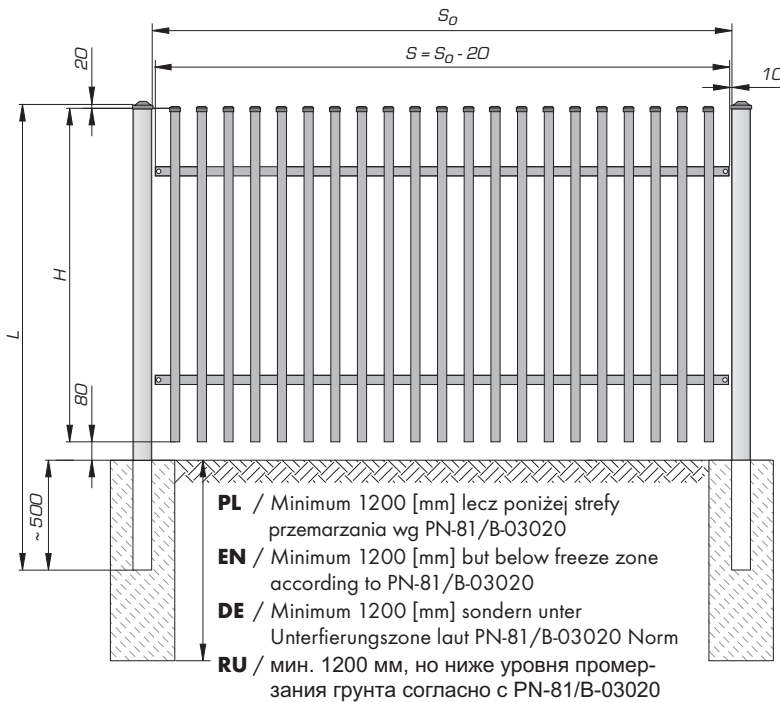

PL / Montaż w gruncie
EN / Assembly in ground
DE / Bodenmontage
RU / Монтаж в грунте

PL / Montaż na stopie
EN / Assembly on a plate
DE / Montage auf einem Fuß
RU / Монтаж на подставке

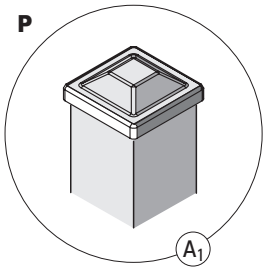

PL / Standard
EN / Standard
DE / Standard
RU / Стандарт

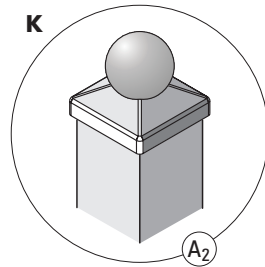

PL / Opcja
EN / Option
DE / Option
RU / Опция

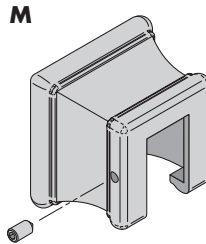

PL / Maskownica - opcja - tylko LUX, oprócz AW.10.52, AW.10.53
EN / Masking element - option - only LUX, excluding AW.10.52, AW.10.53
DE / Blende - option - nur LUX, außer AW.10.52, AW.10.53
RU / Маскировочный элемент - Опция - Только LUX, кроме AW.10.52, AW.10.53

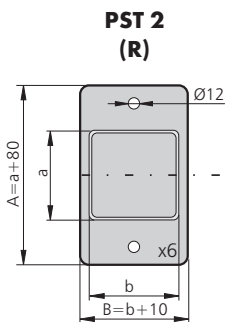

$a \times b = 60 \times 60$ [mm]
 $a \times b = 80 \times 80$ [mm]
 $a \times b = 100 \times 100$ [mm]
 $a \times b = 120 \times 120$ [mm]

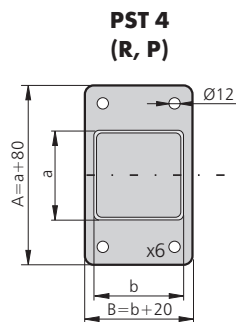

$a \times b = 60 \times 60$ [mm]
 $a \times b = 80 \times 80$ [mm]
 $a \times b = 100 \times 100$ [mm]
 $a \times b = 120 \times 120$ [mm]

--- **PL** / linia ogrodzenia
EN / Fence line
DE / Zaunlinie
RU / Линия ограждения

PL / R - segment, P - brama przesuwna
EN / R - segment, P - sliding gate
DE / R - Zaunfeld, P - Schiebetor
RU / R - секция, P - сдвижные ворота

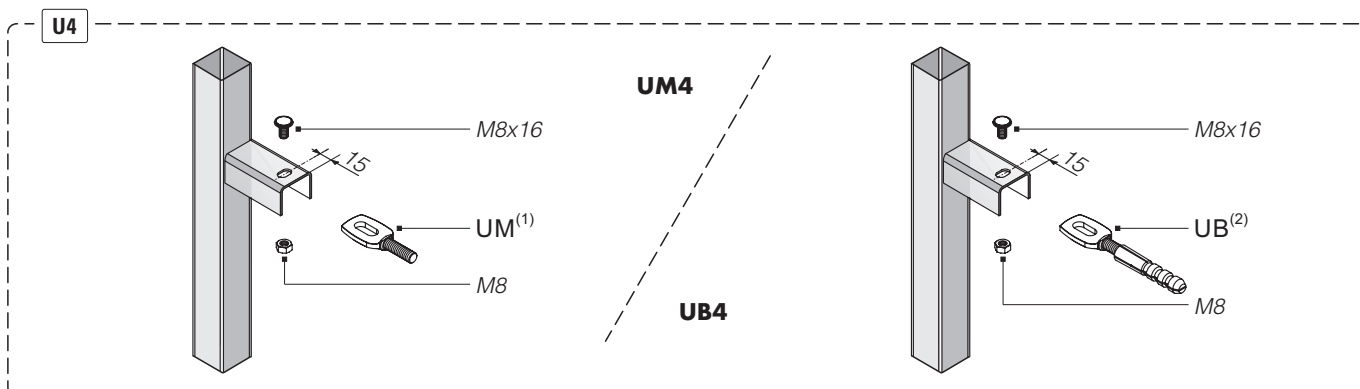
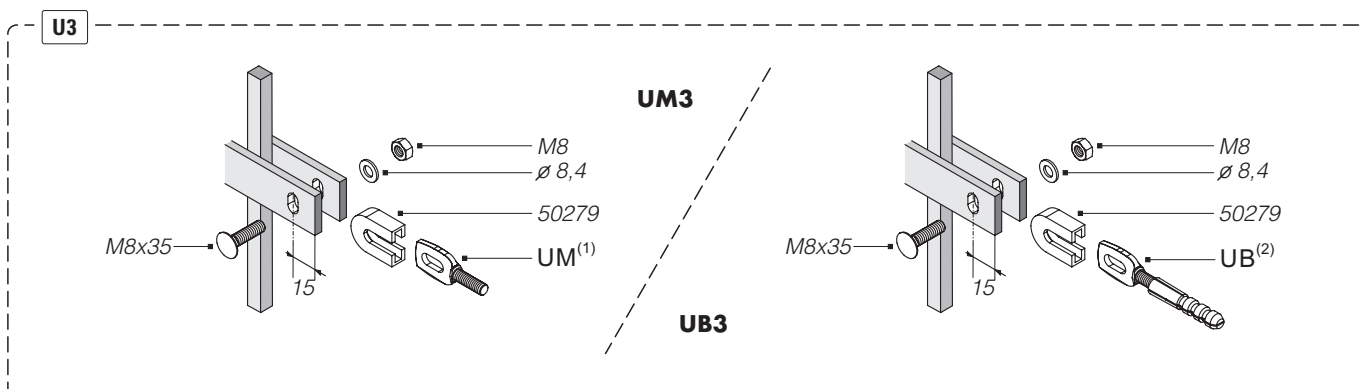
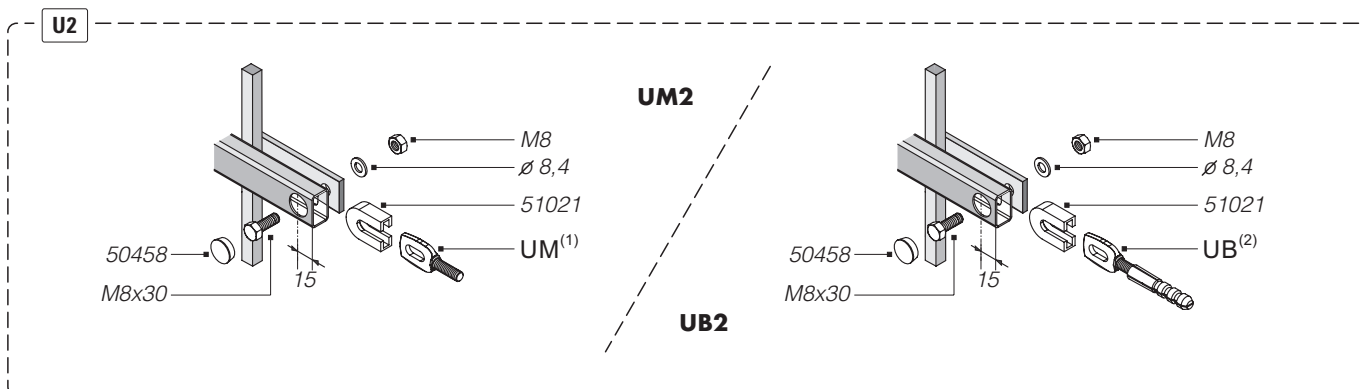
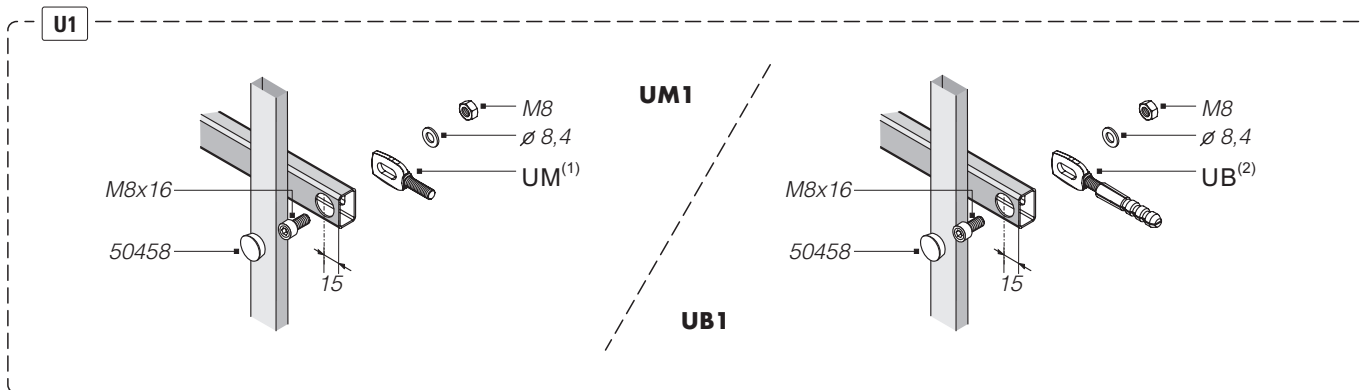

PL / ⁽¹⁾UM - uchwyt do słupka metalowego, ⁽²⁾UB - uchwyt do słupka betonowego

EN / ⁽¹⁾UM - grip to a metal post, ⁽²⁾UB - grip to a stone post

DE / ⁽¹⁾UM - Montagehalter für Stahlpfosten, ⁽²⁾UB - Montagehalter für Betonpfosten

RU / ⁽¹⁾UM - крепление для металлического столбика, ⁽²⁾UB - крепление для каменного столбика

PL / Segment
EN / Segment
DE / Zaunfeld
RU / Секция

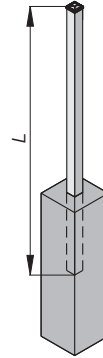

PL / Montaż w gruncie
EN / Assembly in ground
DE / Bodenmontage
RU / Монтаж в грунте

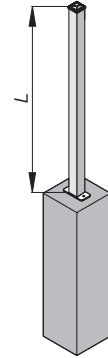

PL / Montaż na stopie
EN / Assembly on a plate
DE / Montage auf einem Fuß
RU / Монтаж на подставке

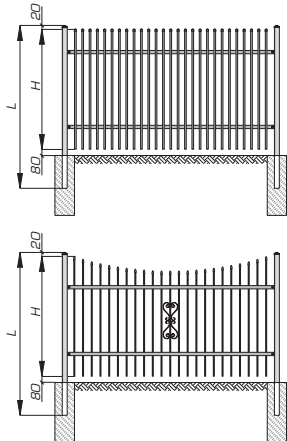
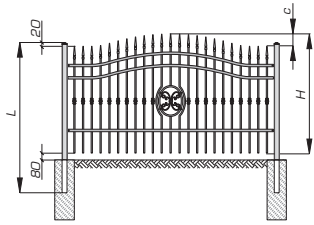
<div style="border: 1px solid black; width: 40px; height: 40px; display: flex; align-items: center; justify-content: center; margin-bottom: 10px;">P</div> <div style="border: 1px solid black; width: 40px; height: 40px; display: flex; align-items: center; justify-content: center; margin-bottom: 10px;">Wk</div>		H	L	L = H + 100 [mm]
		800 - 900	1400	
		901 - 1000	1500	
		1001 - 1100	1600	
		1101 - 1200	1700	
		1201 - 1300	1800	
		1301 - 1400	1900	
		1401 - 1500	2000	
		1501 - 1600	2100	
		1601 - 1700	2200	
		1701 - 1800	2300	
		1801 - 1950	2400	
<div style="border: 1px solid black; width: 40px; height: 40px; display: flex; align-items: center; justify-content: center; margin-bottom: 10px;">Wp</div>		H₁ = H - c	L	L = H - c + 100 [mm]
		800 - 900	1400	
		901 - 1000	1500	
		1001 - 1100	1600	
		1101 - 1200	1700	
		1201 - 1300	1800	
		1301 - 1400	1900	
		1401 - 1500	2000	
		1501 - 1600	2100	
		1601 - 1700	2200	
1701 - 1800	2300			

PL / Brama dwuskrzydłowa, Furtka
EN / Double-leaf gate, Wicket
DE / Zweiflügeltor, Pforte
RU / Распашные ворота, Калитка

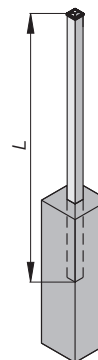

PL / Montaż w gruncie
EN / Assembly in ground
DE / Bodenmontage
RU / Монтаж в грунте

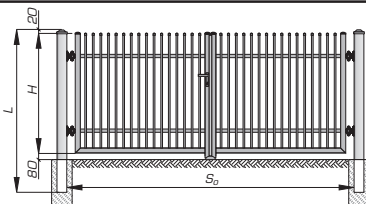
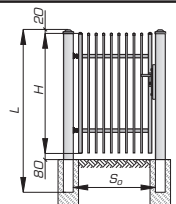
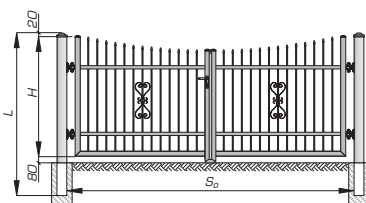
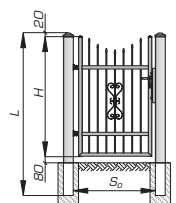
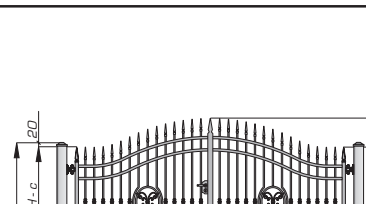
			H	L
<div style="border: 1px solid black; padding: 5px; width: 40px; text-align: center; margin: 0 auto;">P</div>			800 - 900	1600
			901 - 1000	1700
<div style="border: 1px solid black; padding: 5px; width: 40px; text-align: center; margin: 0 auto;">Wk</div>			1001 - 1100	1800
			1101 - 1200	1900
			1201 - 1300	2000
			1301 - 1400	2100
			1401 - 1500	2200
			1501 - 1600	2300
			1601 - 1700	2400
			1701 - 1800	2500
			1801 - 1950	2600
			<div style="border: 1px solid black; padding: 5px; width: 40px; text-align: center; margin: 0 auto;">Wp</div>	
800 - 900	1600			
901 - 1000	1700			
1001 - 1100	1800			
1101 - 1200	1900			
1201 - 1300	2000			
1301 - 1400	2100			
1401 - 1500	2200			
1501 - 1600	2300			
1601 - 1700	2400			
1701 - 1800	2500			

System *Lox* ▪ *Style*

PL / Furtka z zamkiem zwykłym
EN / Wicket with standard lock
DE / Pforte mit Standardschloss
RU / Калитка с обычным замком

PL / Furtka z zamkiem elektromagnetycznym, klamka zablokowana
EN / Wicket with electromagnetic lock, handle blocked
DE / Pforte mit Magnetschloss, Klinke wird waagrecht fixiert
RU / Калитка с электромагнитным замком, ручка заблокирована

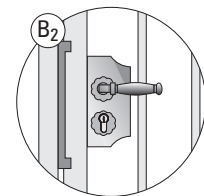
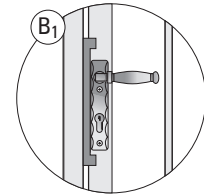
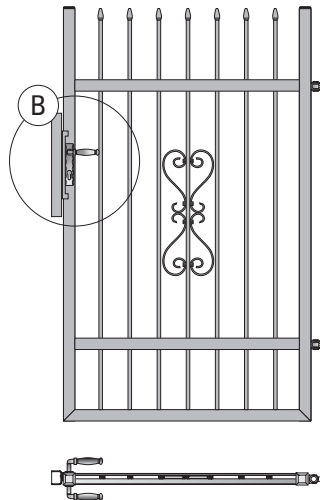
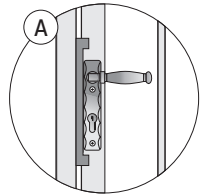
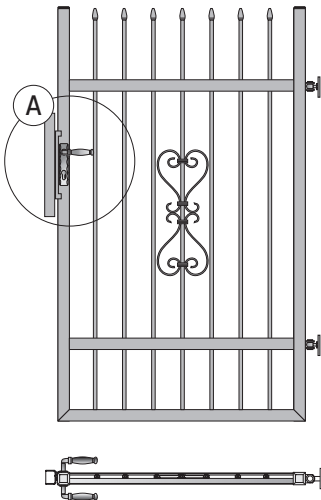

(A) PL / Standard
EN / Standard
DE / Standard
RU / Стандарт

(B₁) PL / Standard
EN / Standard
DE / Standard
RU / Стандарт

(B₂) PL / Opcja Locinox ornamentowy
EN / Option: Locinox with ornament
DE / Option: Locinox Ornament
RU / Опция: Locinox с орнаментом

System *Classic*

PL / Furtka z zamkiem zwykłym
EN / Wicket with standard lock
DE / Pforte mit Standardschloss
RU / Калитка с обычным замком

PL / Furtka z zamkiem elektromagnetycznym
EN / Wicket with electromagnetic lock
DE / Pforte mit Magnetschloss
RU / Калитка с электромагнитным замком

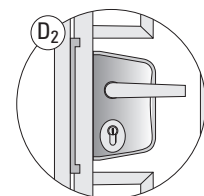
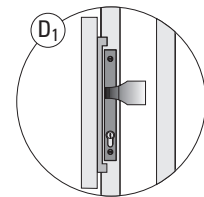
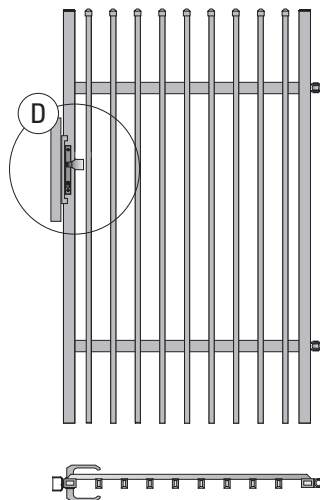
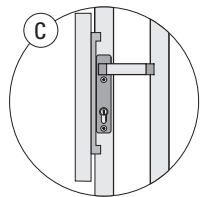
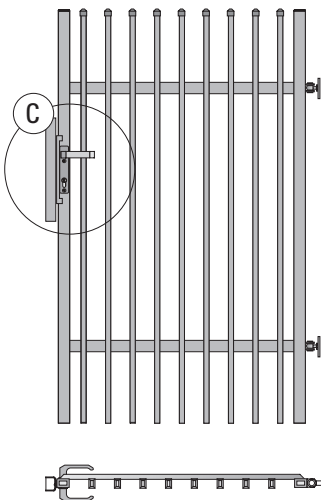

(C) PL / Standard
EN / Standard
DE / Standard
RU / Стандарт

(D₁) PL / Standard
EN / Standard
DE / Standard
RU / Стандарт

(D₂) PL / Opcja Locinox gładki
EN / Option: smooth Locinox
DE / Option: Locinox glatt
RU / Опция: гладкий Locinox

System **Lox** ▪ *Style*

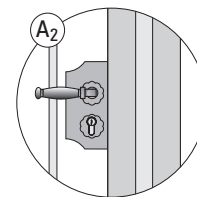
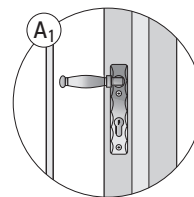
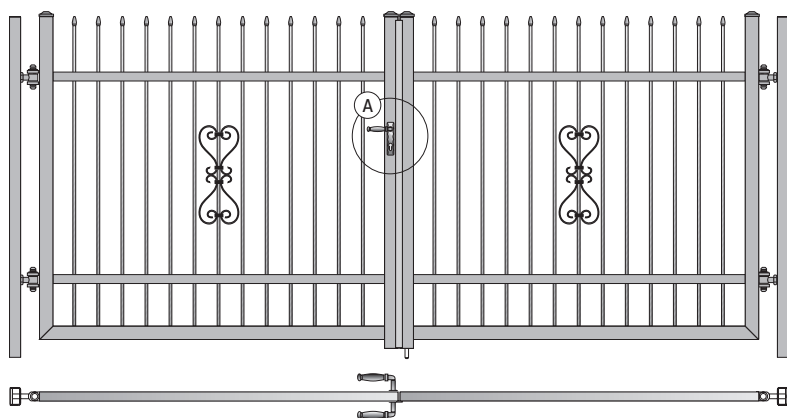

	(A ₁)	(A ₂)
System Lox AW.10.31, AW.10.33, AW.10.34, AW.10.39, AW.10.45 AW.10.46, AW.10.48, AW.10.52, AW.10.53, AW.10.59 AW.10.60, AW.10.61, AW.10.62	standard	opcja
System Lox AW.10.56, AW.10.57, AW.10.58	—	standard
System <i>Style</i>	standard	opcja

System **Classic**

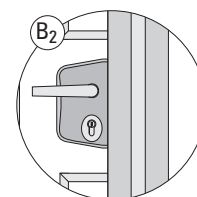
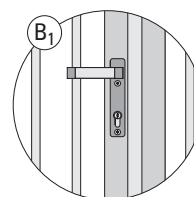
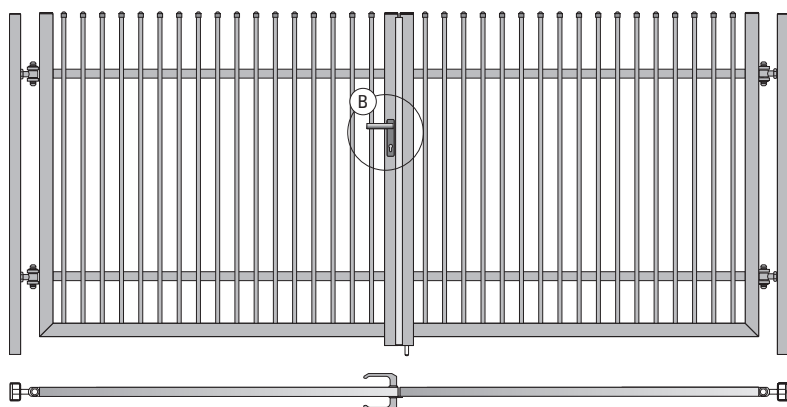

(B₁) **PL** / Standard
EN / Standard
DE / Standard
RU / Стандарт

(B₂) **PL** / Opcja Locinox gładki
EN / Option: smooth Locinox
DE / Option: Locinox glatt
RU / Опция: гладкий Locinox

PL / Standard - **Typ B** Montaż za pomocą płytki (do słupa stalowego)

EN / Standard - **Type B** Plate assembly (for steel)

DE / Standard - **Typ B** Montage mit einer Platte (an den Stahl)

RU / Стандарт - **Тип B** Монтаж с помощью пластины (для стальных)

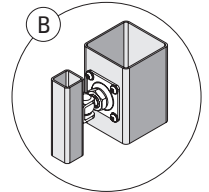
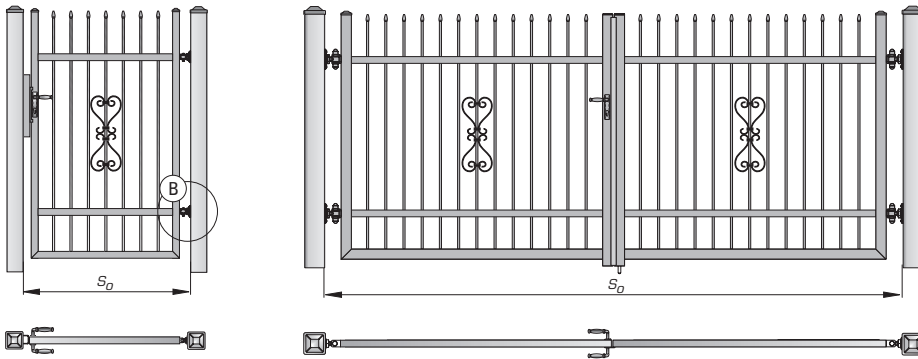

PL / Opcja - **Typ C** Montaż na wklejanej tulei do słupa muranego

EN / Option - **Type C** Glued sleeve assembly for stone posts

DE / Option - **Typ C** Montage mittels einem geklebten Anker an einem gemauerten Pfosten

RU / Опция - **Тип C** Монтаж на вклеиваемой втулке для бетонных столбиков

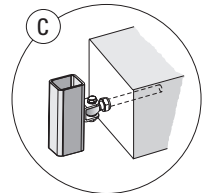
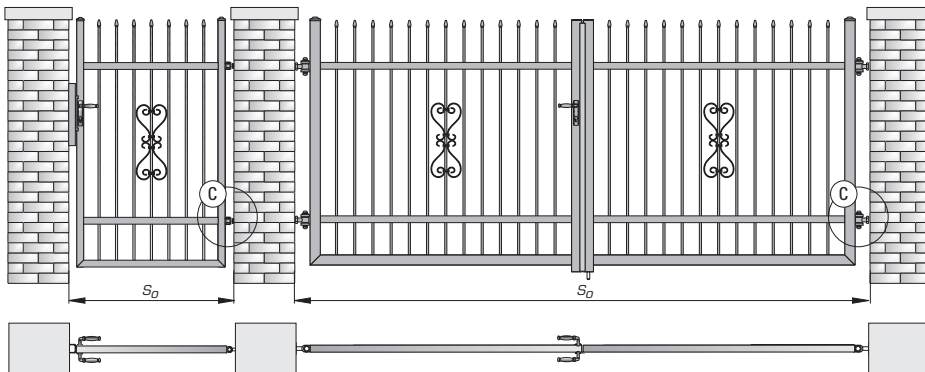

- PL** / Opcja - **Typ E** Montaż z ceownikami montażowymi - krótki ceownik furtki
EN / Option - **Type E** Assembly with assembly sections - short wicket section
DE / Option - **Typ E** Montageart mit U-Montageprofil - kurzes Pfortenmontageprofil
RU / Опция - **Тип E** Монтаж на монтажных профилях - длинный профиль калитки

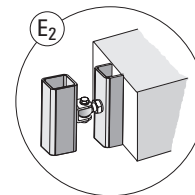
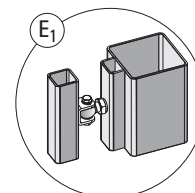
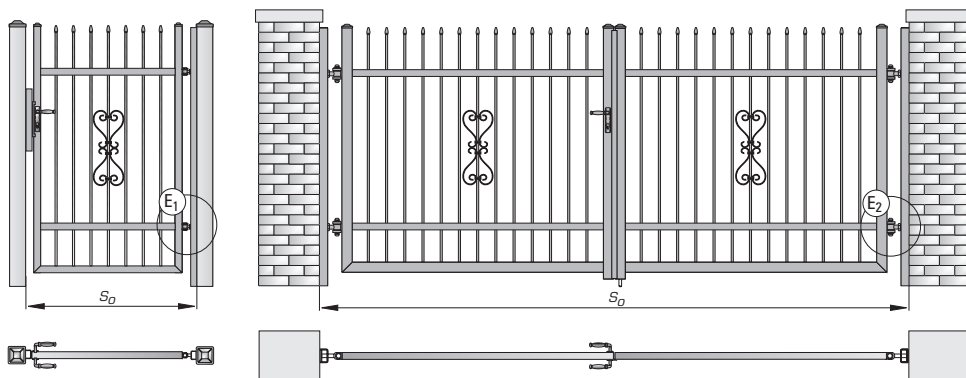

- PL** / Opcja - **Typ O** Montaż z ceownikami montażowymi - długi ceownik furtki
EN / Option - **Type O** Assembly with assembly sections - long wicket section
DE / Option - **Typ O** Montageart mit U-Montageprofil - langes Pfortenmontageprofil
RU / Опция - **Тип O** Монтаж на монтажных профилях - короткий профиль калитки

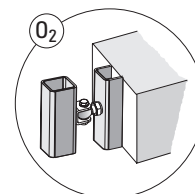
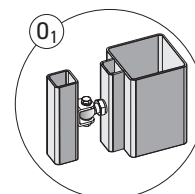
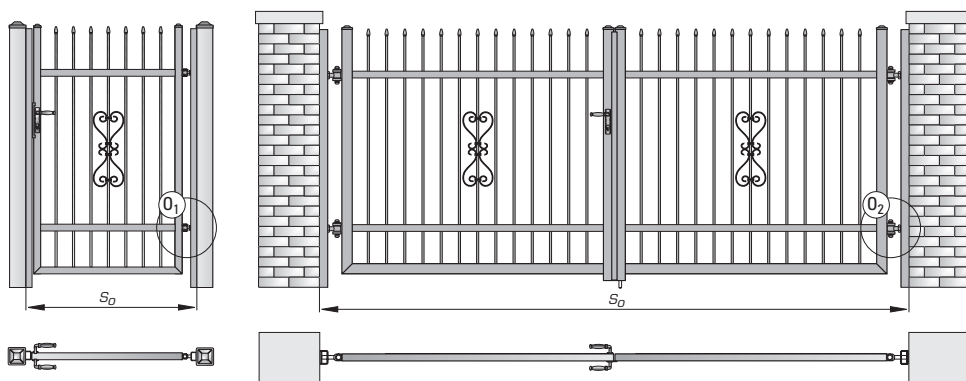

PL / Standard **(B-2)** - Montaż bram na dwóch śrubach fundamentowych

EN / Standard **(B-2)** - Assembly on two foundation anchors

DE / Standard **(B-2)** - Tormontage auf zwei Bodenanker

RU / Стандарт **(B-2)** - Монтаж на двух анкерных болтах

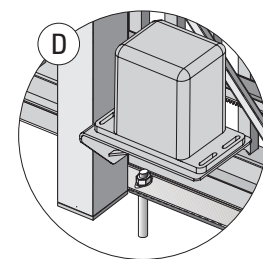
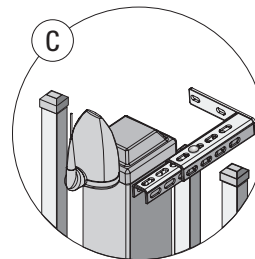
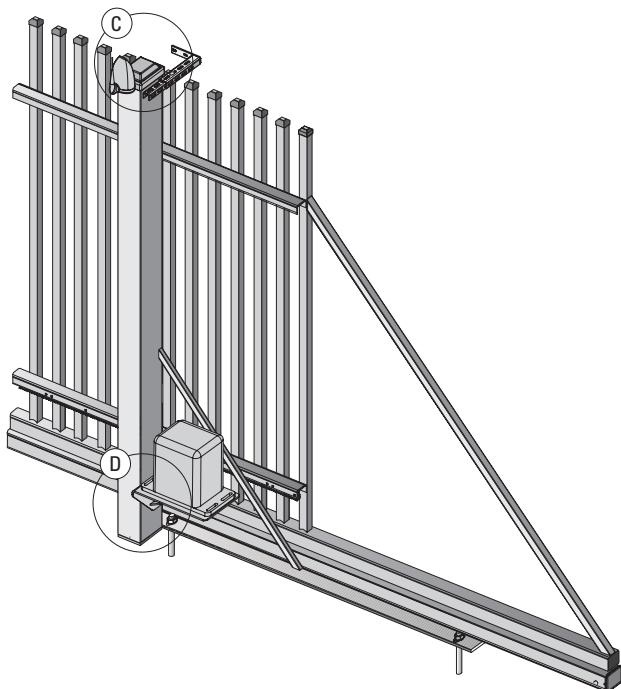
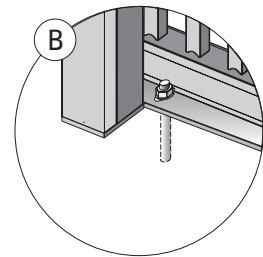
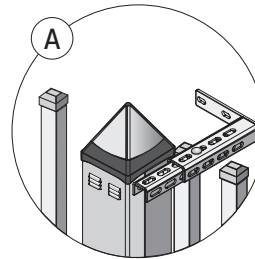
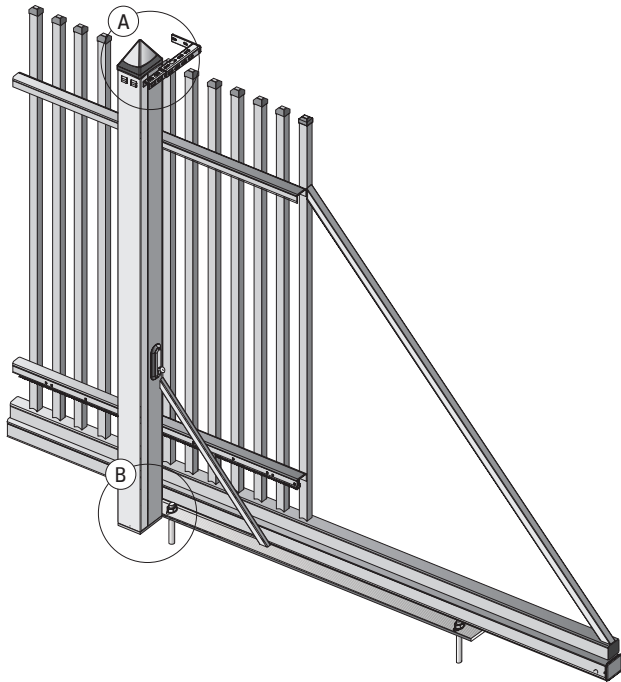

PL / Opcja **(B-3)** - Montaż bram na trzech śrubach fundamentowych

EN / Option **(B-3)** - Assembly on three foundation anchors

DE / Option **(B-3)** - Tormontage auf drei Bodenanker

RU / Опция **(B-3)** - Монтаж на трех анкерных болтах

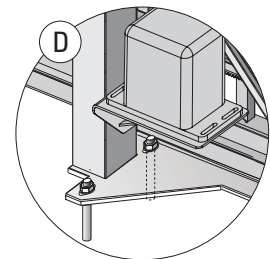
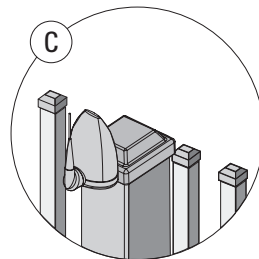
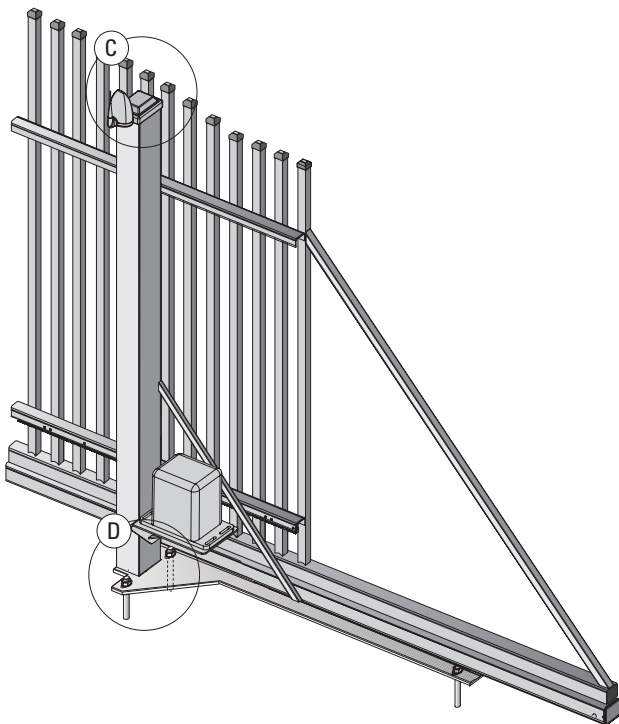
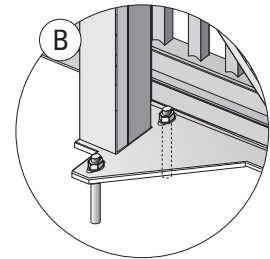
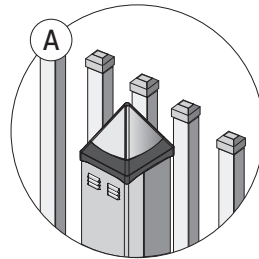
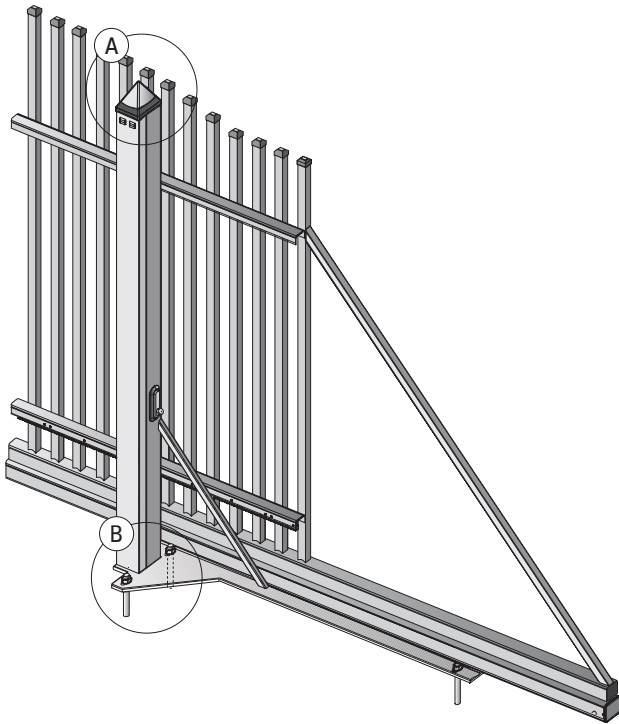

PL / Oznaczenia słupów stosowanych do bram dwuskrzydłowych, furtek i segmentów

EN / Designation posts applied for double-leaf fence gates, wickets and segments

DE / Pfostenbezeichnung für Zweiflügeltore, Pforten und Zaunfelder

RU / Обозначение столбов используемых для распашных ворот, калиток и сегментов

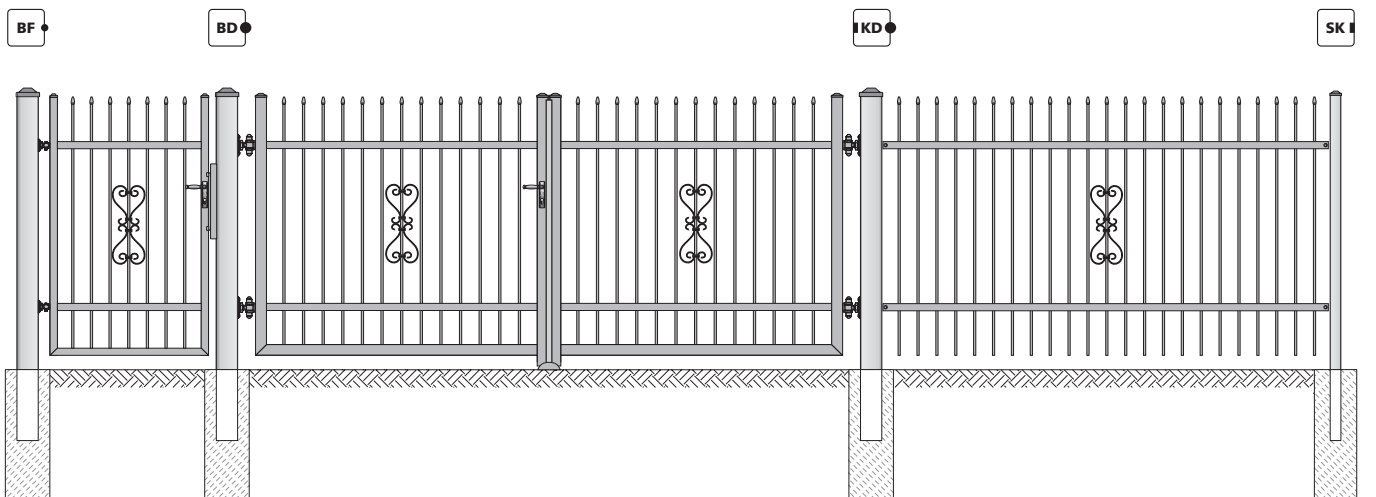
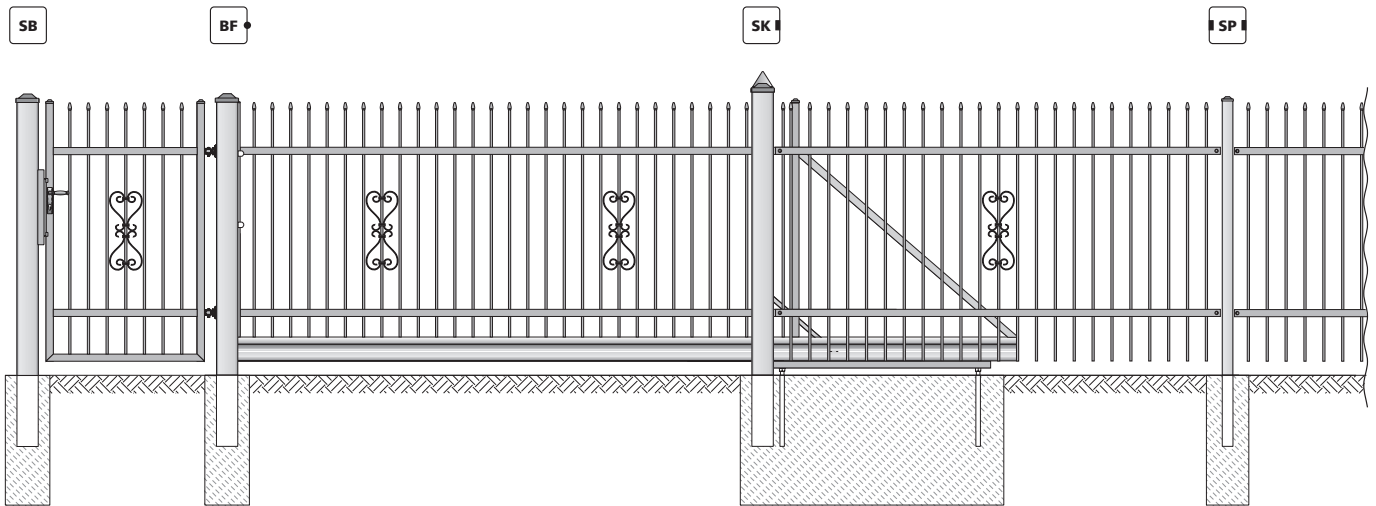

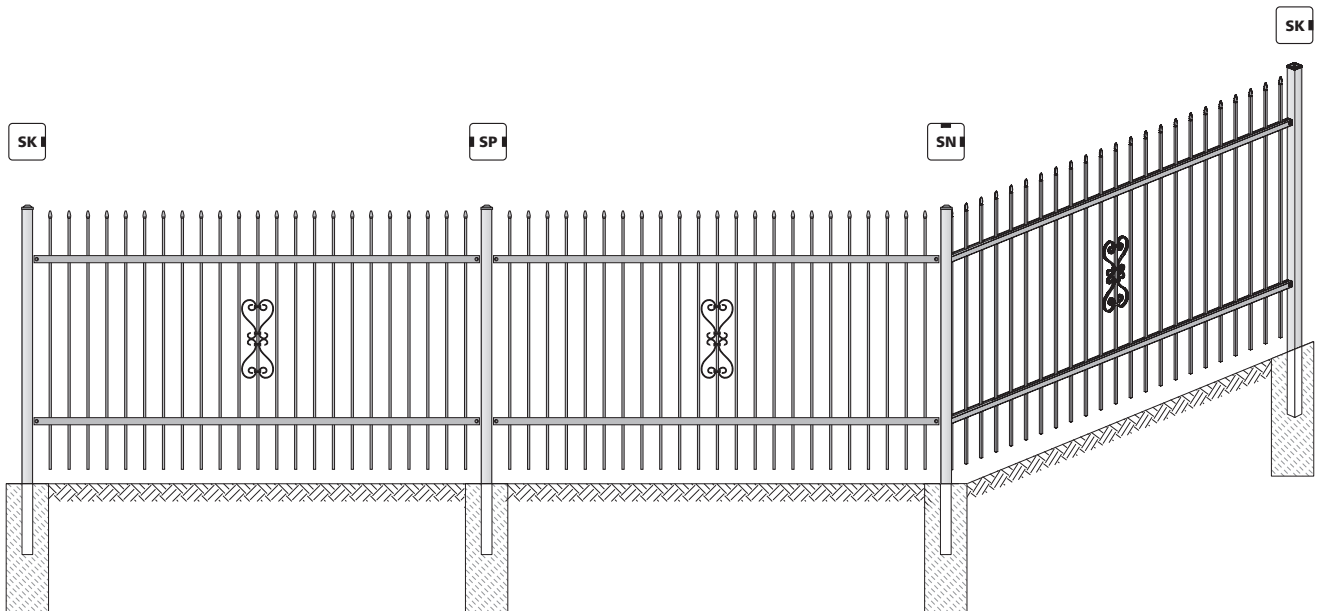
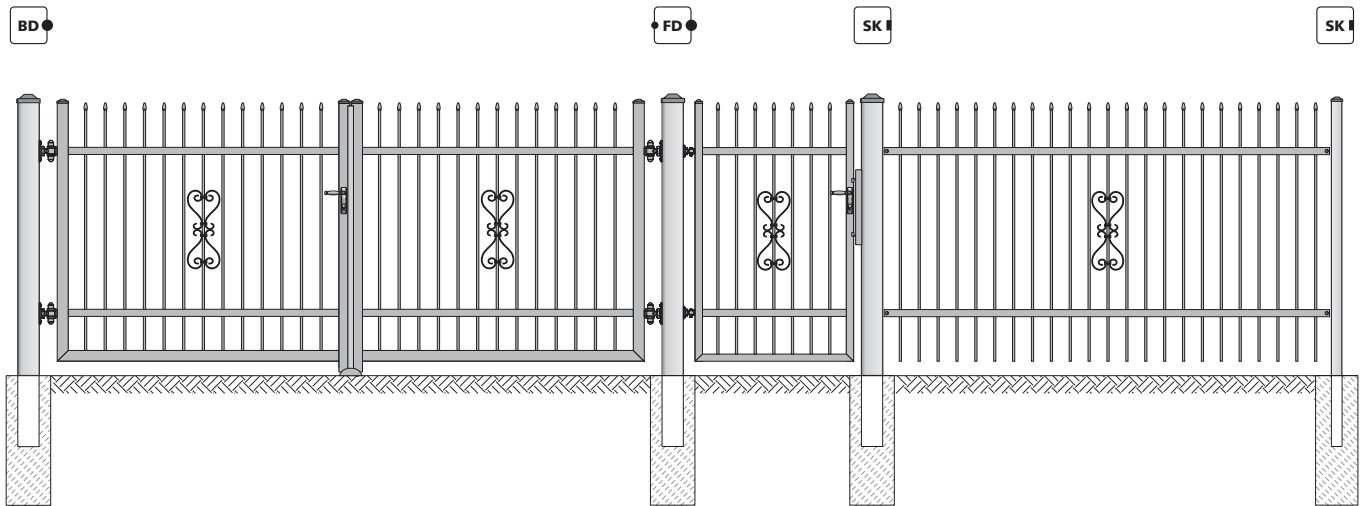

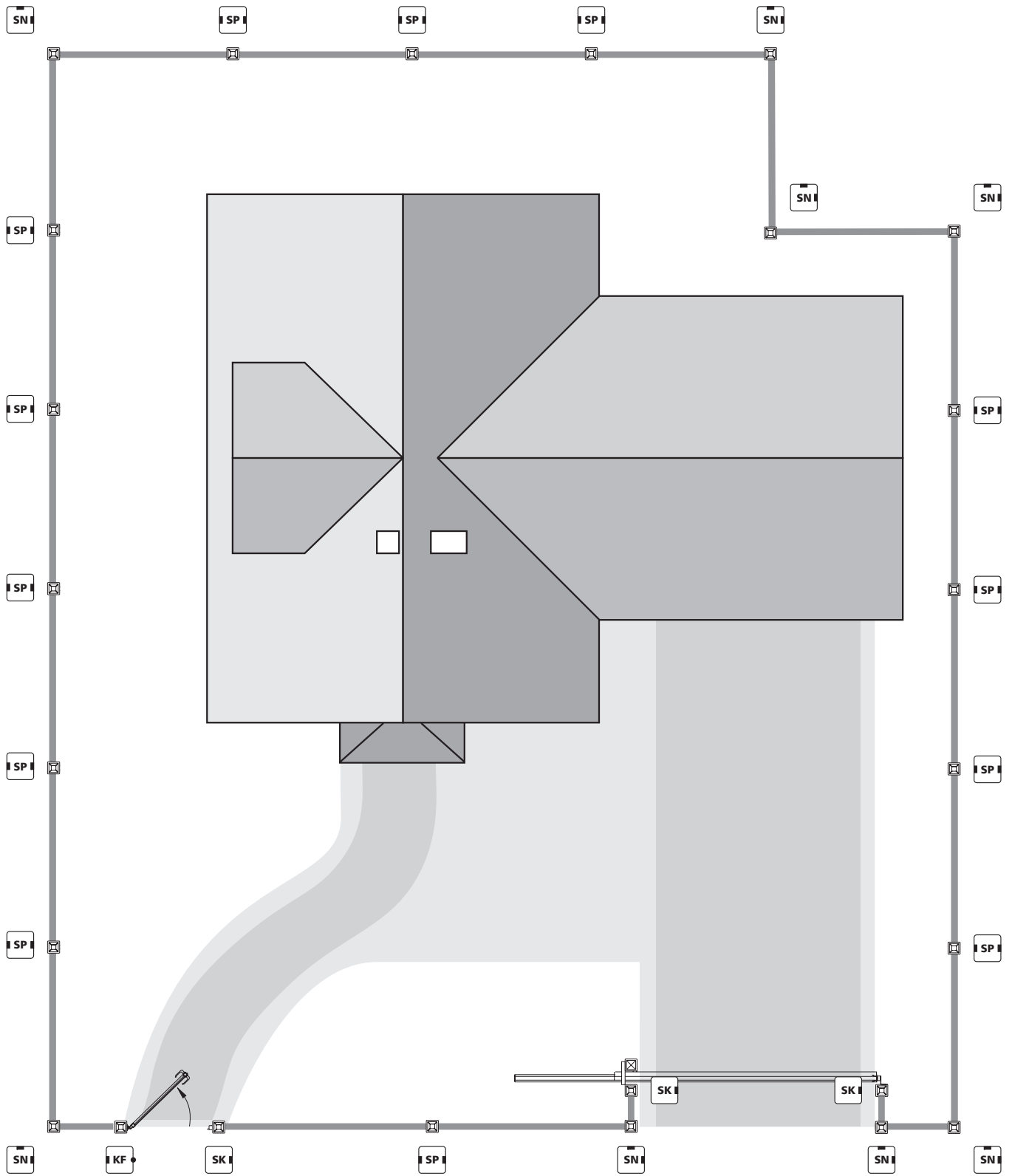

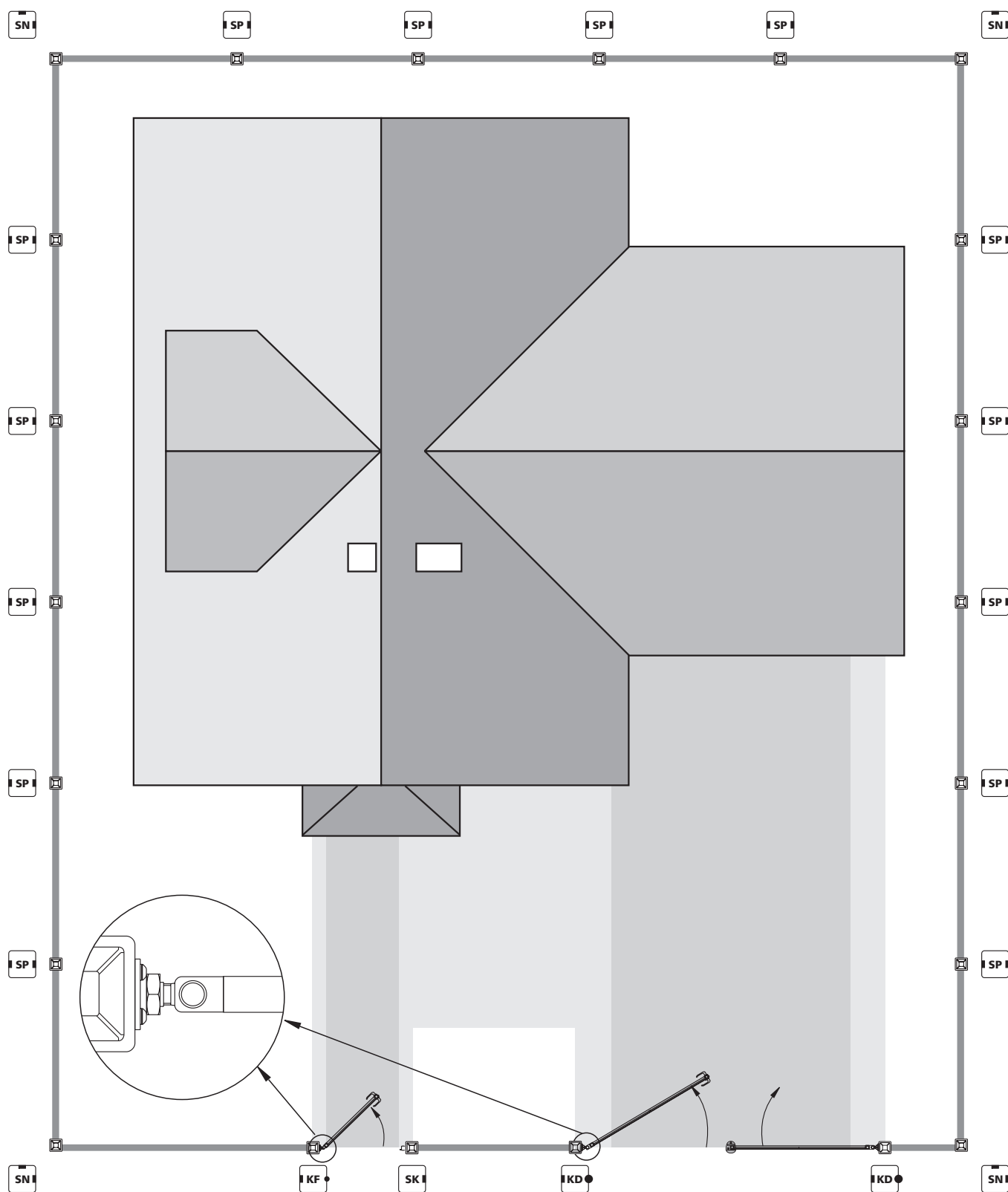

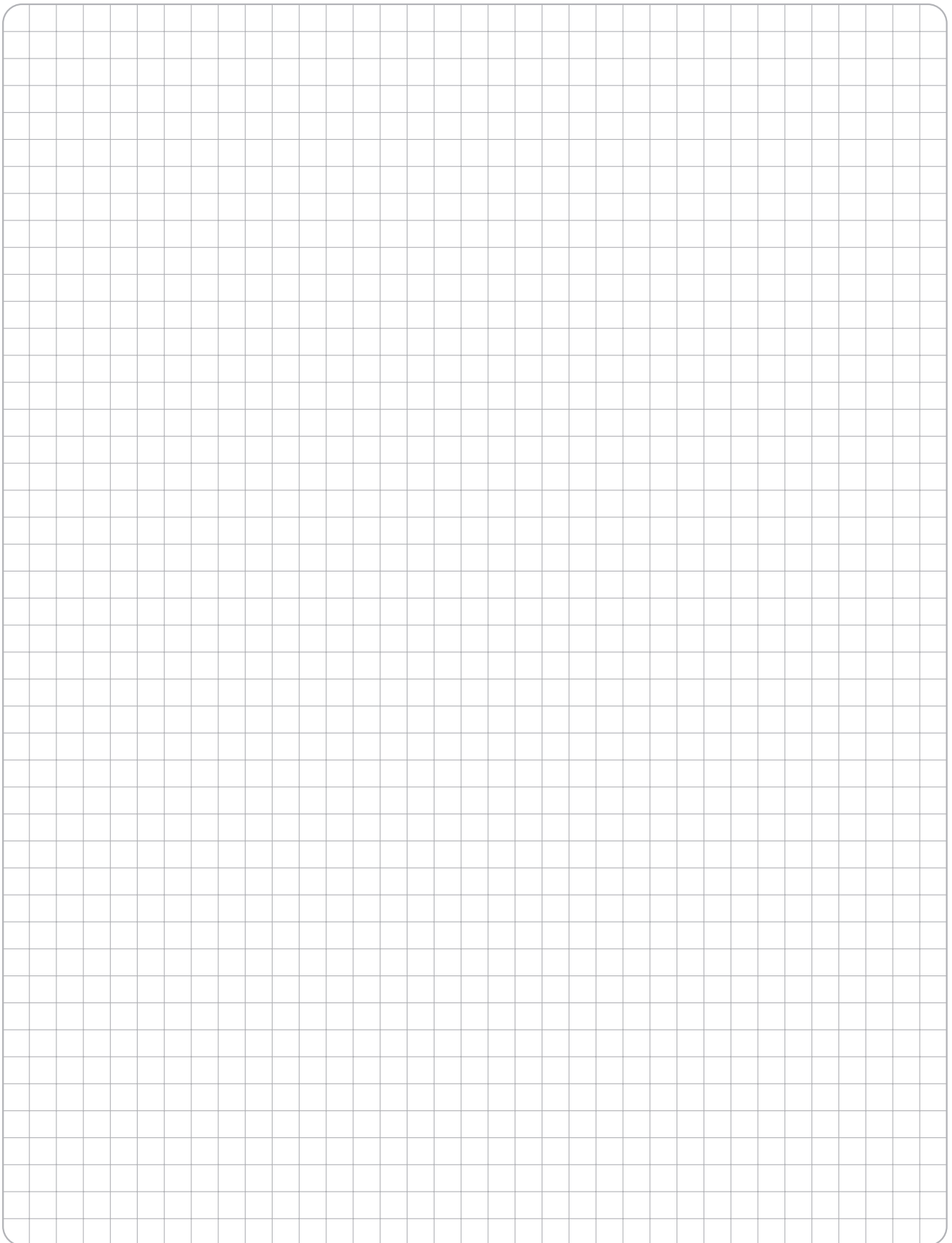

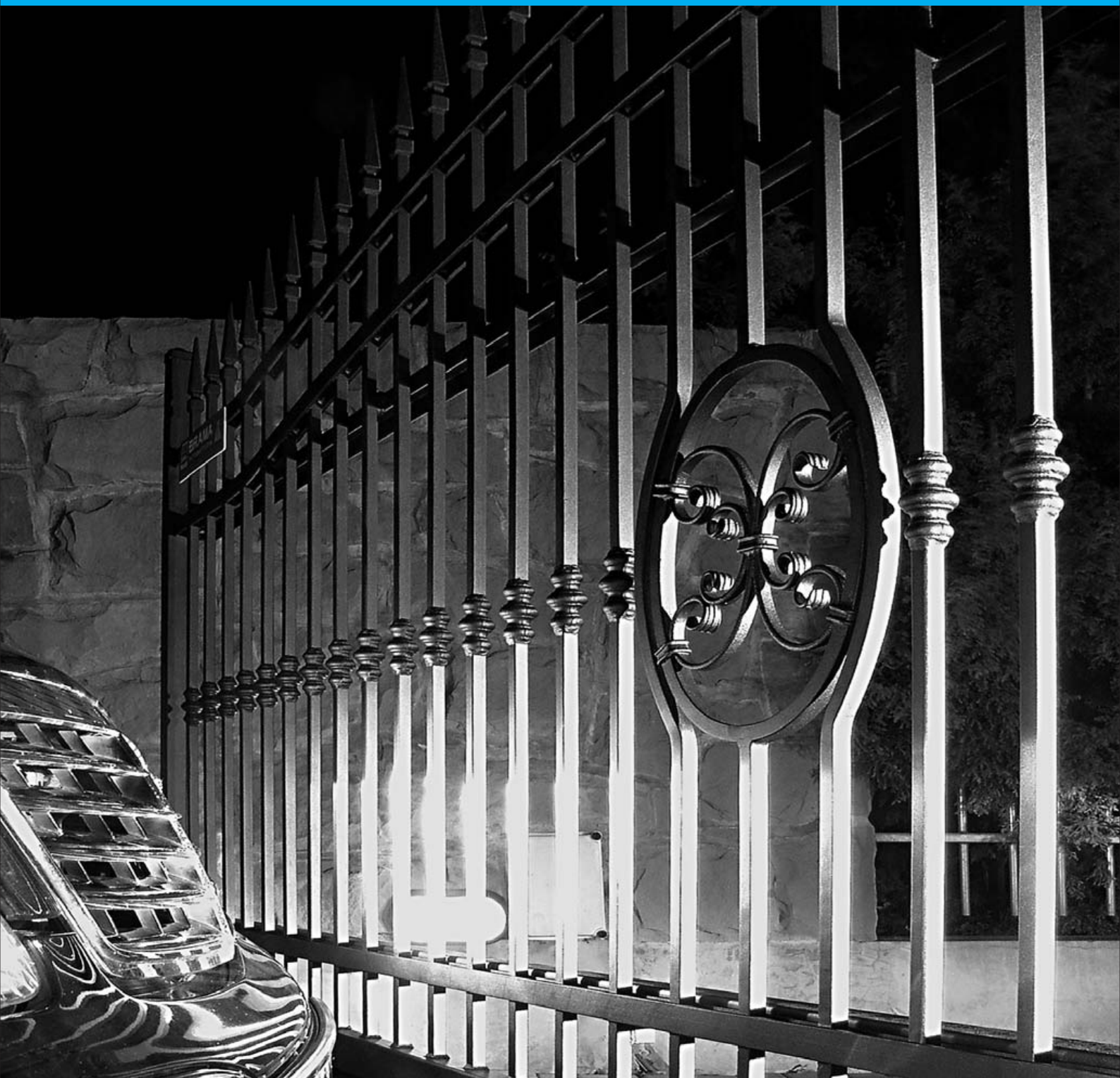

NIP: 734-000-83-23 ■ Regon: 490017080 ■ Wpis do EDzG Wójt Gminy Chełmiec 279

Wydanie 03/02.08



Grupa WIŚNIEWSKI

PL / 33-311 Wielogłowy 153

Tel. (+48 18) 44 77 111

Fax (+48 18) 44 77 110

www.wisniowski.pl

N = 49° 40' 10"

E = 20° 41' 12"